

## 9900 Series Oval Flowmeter/Transmitter with SMART METER MANAGER™

- 2-Wire loop powered flowmeter/transmitter
- 316 Stainless steel measuring unit
- Automatic temperature compensation
- Pocketless measuring chamber
- Low pressure drop
- 2-Wire mass or volume output
- 4-20 mA analog output with HART® communication
- Smart Meter Manager™ can be located in UMB
- User configurable, scalable pulse output
- Comprehensive alarms for both process flow and internal diagnostic checks
- Easy access programming
- 10-Point meter factor linearization
- UL/cUL listed NEMA 4X
- Intrinsically safe

### DESCRIPTION

The Brodie 9900 Series Oval Flowmeter/Transmitter with Smart Meter Manager™ (SMM) is a very high accuracy, positive displacement meter which utilizes microprocessor based electronics to provide multivariable flow computation and output for volumetric and mass measurement requirements. It is designed for use in the chemical, industrial, food and beverage, pharmaceutical and hydrocarbon process industries.

One of the most significant features of these meters is their ability to handle both low and high viscosity products with a low pressure drop across the meter. They are supplied in a compact, 3-piece design which uses both front and rear flanges instead of the closed-end body configuration found in traditional oval flowmeters. Available sizes are 1/2" through 3".

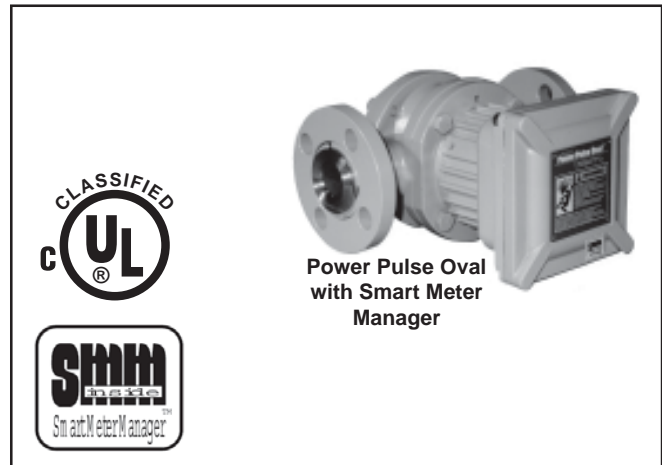

“Smart Meter Manager inside” best defines the Brodie 9900 Oval Flowmeter/Transmitter. Past products have only delivered simple square wave pulse outputs that represented raw unfactored meter pulses (K-Factors).

K-Factors require additional processing by a secondary piece of electronics to convert to engineering units or factored 4-20 mA analog output. The need for secondary electronics, additional wiring and power supplies can be eliminated by using the SMART METER MANAGER™. SMM is a multivariable flow computer that fits inside the standard Brodie UMB (Universal Mounting Box). Because the SMM only requires 4-20 mA Loop power, it hooks up as a simple 2-wire transmitter. The SMM expands the capability of the Oval to include factored 2-wire, 4-20 mA output, and with ATC (Automatic Temperature Compensator) the once simple K-Factor now represents both corrected volume and mass flow. This can be in the form of a 4-20 mA output, gross total and/or inventory total. In addition, transistor contacts provide scaled pulse outputs in both net and gross values. An additional contact provides an alarm output. This expanded capability is enhanced by HART® communications and the ability to use the standard 275 HART communicator.

## Brodie Smart Meter Manager (SMM) Technology

- 2-wire, loop-powered device for ease of wiring and installation
- 4-20 mA analog output with Bell-202 modulated HART communication channel
- User selectable 0% and 100% analog output ranges with optional smoothing
- Flexible (mix & match) units of measure for flowrates, totals, temperatures, densities, etc.
- Capability for two flow totalizers: Resettable and inventory
- User configurable, scalable pulse output for various engineering units
- Comprehensive alarms for both process flow and internal diagnostic checks

Flowmeters are supplied with the SMM mounted within the explosion proof UMB enclosure.

Capabilities include:

- Volumetric and Mass Measurement in selected engineering units
- Automatic Temperature Compensation
- Analog and Pulse Output to remote instrumentation
- Diagnostic and System Alarms
- 2-Wire Mass or Volume Output
- Model 275 Hand-held Interface

The Smart Meter Manager provides multivariable flow measurement capabilities that include net/gross volume, low flow cutoff, temperature compensation, accumulative and resettable totalization, product density and mass flow inference. All measure parameters are factory set with the capability of field programming. The BERT must be located remotely.

## PRINCIPLE OF OPERATION

The Oval Flowmeter accurately measures liquid flow by using a slight pressure differential to rotate a pair of oval gears located within the measuring chamber. Each complete rotation of the gears (rotors) displaces a fixed amount of liquid from the inlet to the outlet of the meter in a continuous flow pattern. When in the position as shown in Figure 1, Diagram 1, all of the driving torque resulting from differential pressure is applied to Gear A. Gear B has zero driving torque since equal areas of gear surface on opposite sides of the axis of rotation are exposed to higher inlet pressure. As the gears begin to rotate (Diagram 2), the torque applied to Gear A decreases but Gear B now has driving torque due to increased area exposed to the high pressure. At the position shown in Diagram 3, all of the driving torque is exerted on Gear B and Gear A has decreased to zero. This alternate driving action provides a smooth rotation of almost constant torque without dead spots.

Because slippage between the gears and the wall is minimal, the meter is essentially unaffected by the viscosity and lubricity of the liquids being metered.

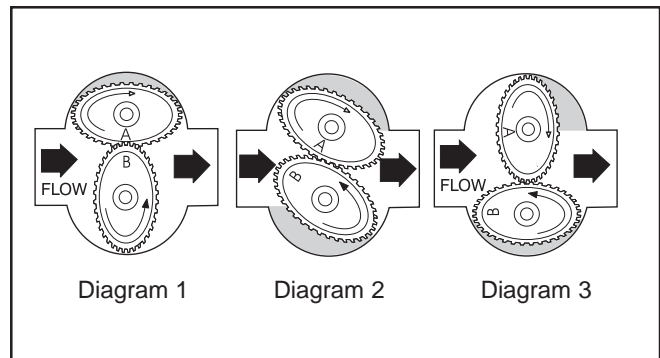

Figure 1 Principle of Operation

## SPECIFICATIONS

### ⚠ WARNING

**Do not operate this instrument in excess of the specifications listed below. Failure to heed this warning can result in serious personal injury and/or damage to the equipment.**

## FLOWMETER

### Viscosity

Basic viscosity classifications include:

Standard viscosity class from 0.2 to 500 centipoise

High viscosity class above 500 centipoise

### Materials of Construction

Body: Stainless Steel CF8M w/Polyurethane Paint

Rotors: 316 Stainless Steel

Shafts: 316 Stainless Steel (Standard), Chrome Plated (Optional)

Rotor Bearings: Carbon (Standard) Waukesha or Carbon

Ceramic (Optional) for corrosive/abrasive products

O-rings: Viton® (Standard), Teflon®, EPR, Silicon (Optional) See Model Meter Code.

**Capacities:** See Tables 1A (Mass) and 1B (Volumetric)

### Performance

Accuracy:  $\pm 0.25\%$  on viscosities of 5 centipoise and above

$\pm 0.05\%$  on viscosities from 0.2 to 5 centipoise

Repeatability:  $\pm 0.05\%$  or better

Accuracy vs. Pressure Drop: See Figure 3

### Ratings

Maximum Working Temperature  
(Limited to electronics)

Process Operating Temperature

Class A:  $-40$  to  $230^{\circ}\text{F}$  ( $-40$  to  $110^{\circ}\text{C}$ )

Class C:  $230$  to  $356^{\circ}\text{F}$  ( $110$  to  $180^{\circ}\text{C}$ )

Ambient Operating Temperature:

$-40^{\circ}\text{F}$  to  $150^{\circ}\text{F}$  ( $-40^{\circ}\text{C}$  to  $65^{\circ}\text{C}$ )

Storage Temperature:

$-58^{\circ}\text{F}$  to  $175^{\circ}\text{F}$  ( $-50^{\circ}\text{C}$  to  $79^{\circ}\text{C}$ )

SAMA Vibration Specification:  
 PMC 31.1, Table 2, Condition 3  
 For Process Pipe Mounted Instrumentation  
 Humidity 0-95% R.H. Non-Condensing

Stainless Steel, 150 lb. ANSI Fig.: 275 psi (1895 kPa)  
 Stainless Steel, 300 lb. ANSI Fig.: 720 psi (4960 kPa)

**Mechanical Connections**

Standard: 1/2" to 3", 150 lb. ANSI flange  
 Optional: 1/2" to 3", 300 lb. ANSI flange, DIN, Tri-Clover®

**Electrical Classifications:**

UL/cUL - Intrinsically Safe  
 Class I, Groups A, B, C, and D  
 Class II, Groups E, F, and G  
 Class III  
 NEMA 4X

UL/cUL listed - Hazardous locations

Class I, Groups C and D  
 Class II, Groups E, F, and G

NEMA 4X

**Power Supply and Maximum Load Resistance**

See Figure 2.

**Input Power** - Derived from Analog Output  
 (2-wire 4-20mA loop transmitter)

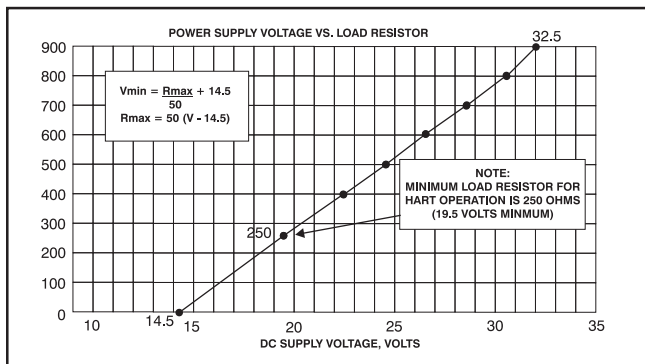

Figure 2 Maximum Load Resistance

**Input Signals**

*RTD Temperature Input*  
 Supports 100 ohm, platinum or copper RTD input for temperature, 3 or 4 wire

**Output Signals**

*4-20 mA Analog Output*  
 Update Rate: 4 times per sec.  
 Range: 3.8 to 22.0 mA

*Contact Output*

Open collector: assignable to alarm output, reverse flow indicator or manual value  
 Maximum off-state voltage: 30 Vdc  
 Maximum on-state voltage: 1.2 Vdc  
 Maximum on-state current: 40 mA

*Standard Pulse Outputs*

Type: Open collector, two channels (Two single-phase)  
 Frequency Range: Zero to 500 Hz  
 Maximum off-state voltage: 30 Vdc  
 Maximum on-state voltage: 1.2 Vdc  
 Maximum on-state current: 40 mA

**Ambient Temperature Limit**

-40°F to 150°F (-40°C to 65°C)  
 For conditions outside of range consult factory.

**Loop Current Linearity**

Less than 0.1% from min. to max. current

**Temperature Influence on Loop Current**

Less than 0.007% per °C

**Loop Voltage Influence on Loop Current**

Less than 0.002%/Vdc

**Load Resistance Influence on Loop Current**

±0.1% full scale

**Dimensions**

See Figure 6. For Certified Dimension Prints, contact factory

**Typical Applications**

Refer to Figures 7 and 8

Flow Range Capacities - M <sup>3</sup> /H									
Size	Model Number	Cold Water	Hot Water 140 to 230° F	LPG 0.2 cP	Gasoline 0.3 to 0.7 cP	Kerosene 0.7 to 1.8 cP	Light Oil to 4 cP	2 Heavy Oil to 300 cP	5
1/2"	02/52	0.3 to 1.5	0.4 to 1	0.7 to 1.8	0.4 to 1.8	0.3 to 1.8	0.15 to 2	0.08 to 2	2
1"	53	0.55 to 3	0.7 to 2	1.1 to 3.6	0.7 to 3.6	0.55 to 3.6	0.28 to 4	0.15 to 4	4
1"	55	1 to 7	1.2 to 5	1.8 to 8.5	1.2 to 8.5	1 to 8.5	0.4 to 10	0.26 to 10	10
1-1/2"	56	2 to 14	2.5 to 1	3.5 to 17	2.5 to 17	2 to 17	0.9 to 20	0.6 to 20	20
2"	57	4 to 30	5 to 20	8 to 35	5 to 35	4 to 35	2 to 40	1.2 to 40	40
3"	59	8 to 60	10 to 40	15 to 70	10 to 70	8 to 70	6 to 90	4 to 90	90

Flow Range Capacities - USGPM									
Size	Model Number	Cold Water	Hot Water 140 to 230° F	LPG 0.2 cP	Gasoline 0.3 to 0.7 cP	Kerosene 0.7 to 1.8 cP	Light Oil to 4 cP	2 Heavy Oil to 300 cP	5
1/2"	02/52	1.3 to 6.6	1.8 to 4.4	3.1 to 7.9	1.8 to 7.9	1.3 to 7.9	0.7 to 8.8	0.4 to 8.8	8.8
1"	53	2.4 to 13.2	3.1 to 8.8	4.8 to 15.9	3.1 to 15.9	2.4 to 15.9	1.2 to 17.6	0.7 to 17.6	17.6
1"	55	4.4 to 30.8	5.3 to 22.0	7.9 to 37.4	5.3 to 37.4	4.4 to 37.4	1.8 to 44.0	1.1 to 44.0	44.0
1-1/2"	56	8.8 to 61.6	11.0 to 4.4	15.4 to 74.9	11.0 to 74.9	8.8 to 74.9	4.0 to 88.1	2.6 to 88.1	88.1
2"	57	17.6 to 132.1	22.0 to 88.1	35.2 to 154.1	22.0 to 154.1	17.6 to 154.1	8.8 to 176.1	5.3 to 176.1	176.1
3"	59	35.2 to 264.2	44.0 to 176.1	66.1 to 308.2	44.0 to 308.2	35.2 to 308.2	26.4 to 396.3	17.6 to 396.3	396.3

Flow Range Capacities - LPM									
Size	Model Number	Cold Water	Hot Water 140 to 230° F	LPG 0.2 cP	Gasoline 0.3 to 0.7 cP	Kerosene 0.7 to 1.8 cP	Light Oil to 4 cP	2 Heavy Oil to 300 cP	5
1/2"	02/52	5.0 to 25.0	6.7 to 16.7	11.7 to 30.0	6.7 to 30.0	5.0 to 30.0	2.5 to 33.3	1.3 to 33.3	33.3
1"	53	9.2 to 50.0	11.7 to 33.3	18.3 to 60.0	11.7 to 60.0	9.2 to 60.0	4.7 to 66.7	2.5 to 66.7	66.7
1"	55	16.7 to 116.7	20.0 to 83.3	30.0 to 141.7	20.0 to 141.7	16.7 to 141.7	6.7 to 166.7	4.3 to 166.7	166.7
1-1/2"	56	33.3 to 233.3	41.7 to 16.7	58.3 to 283.3	41.7 to 283.3	33.3 to 283.3	15.0 to 333.3	10.0 to 333.3	333.3
2"	57	66.7 to 500.0	83.3 to 333.3	133.3 to 583.3	83.3 to 583.3	66.7 to 583.3	33.3 to 666.7	20.0 to 666.7	666.7
3"	59	133.3 to 1000.0	166.7 to 666.7	250.0 to 1166.7	166.7 to 1166.7	133.3 to 1166.7	100.0 to 1500.0	66.7 to 1500.0	1500.0

Figure 3 Accuracy vs. Pressure Drop

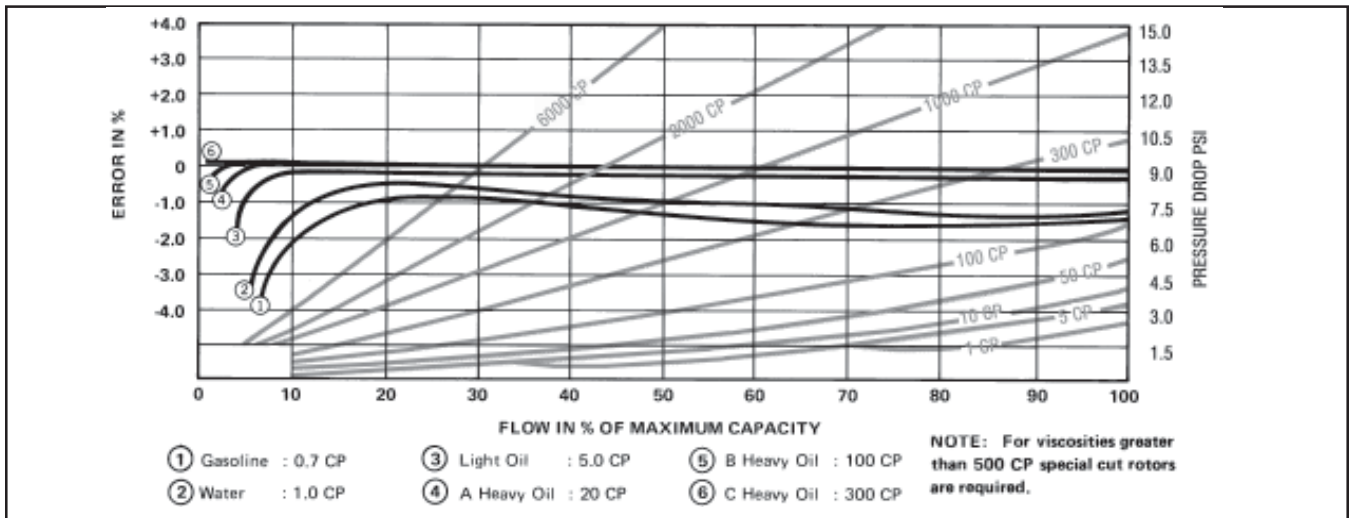
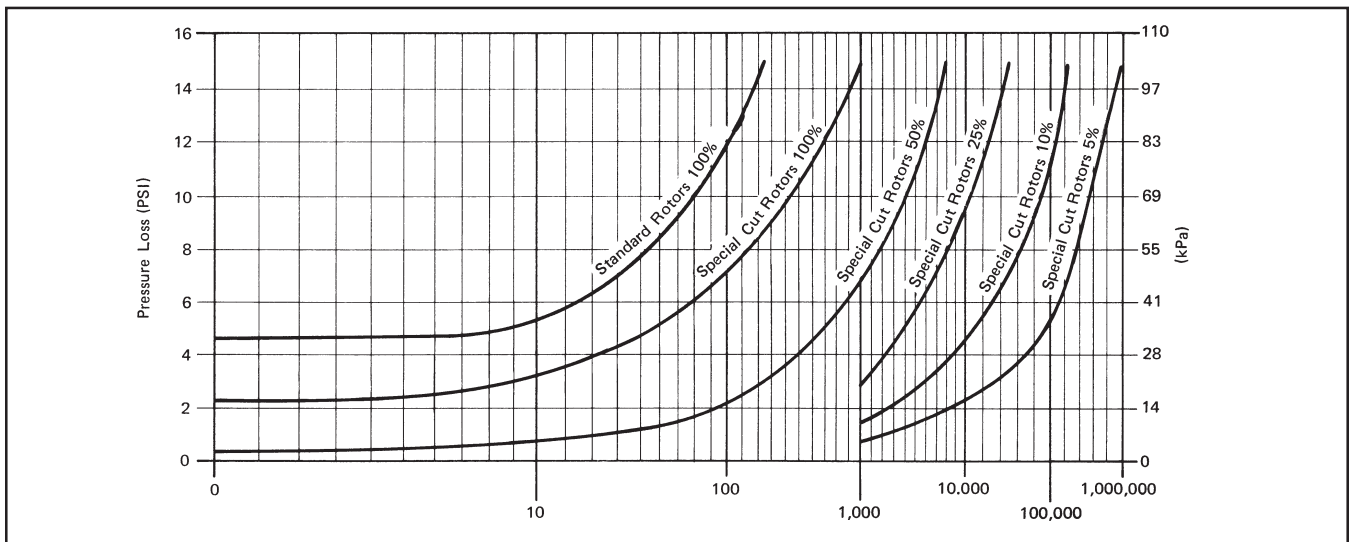
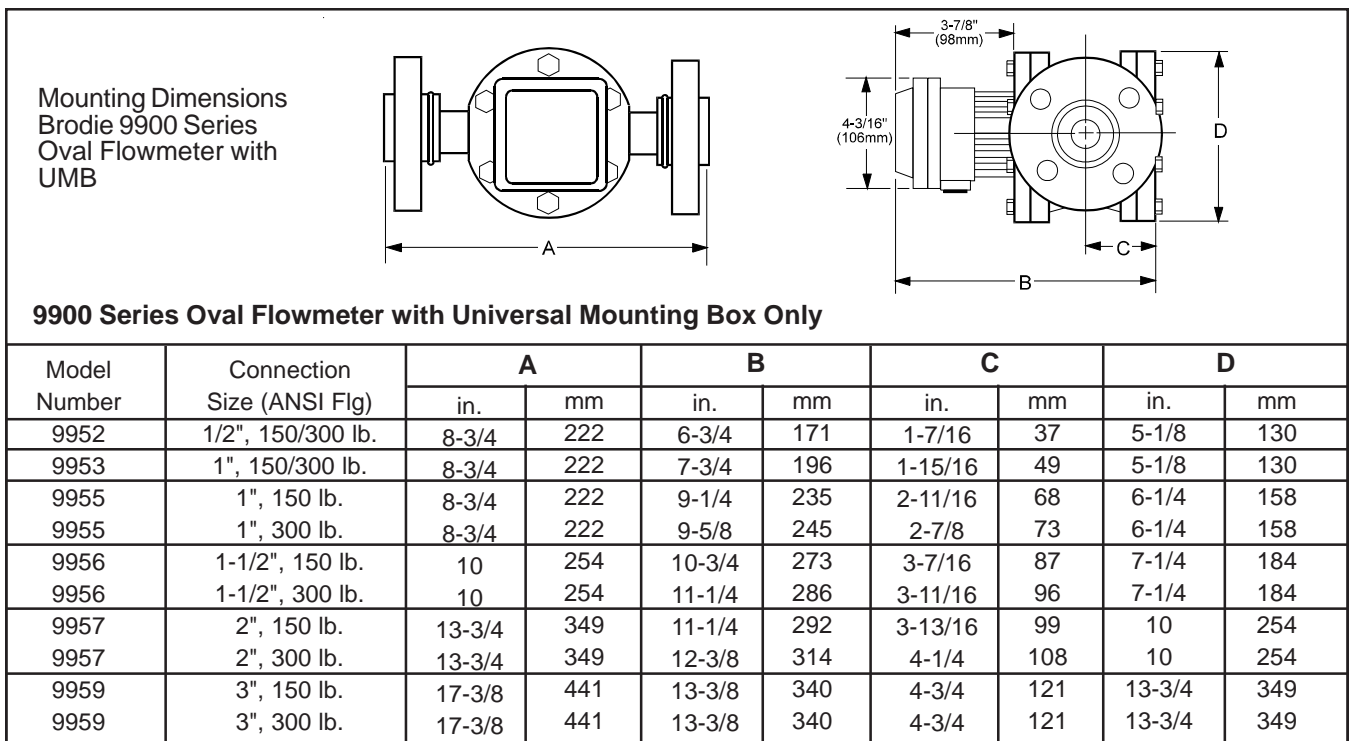
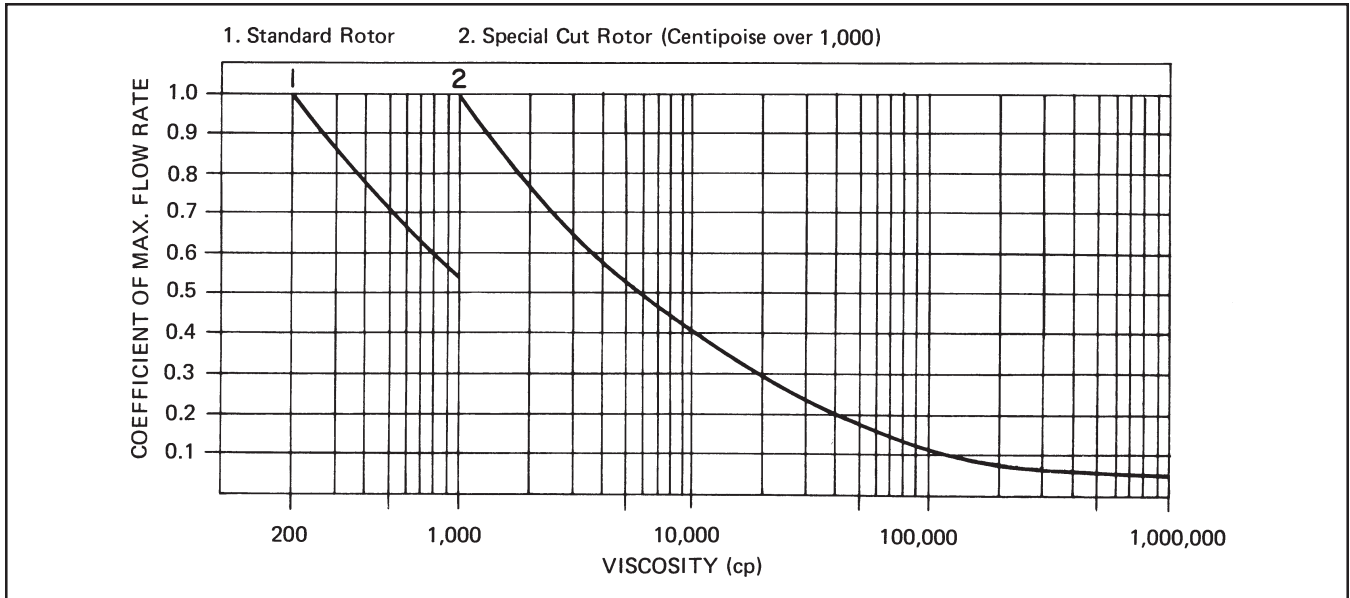

Figure 4 Pressure Loss and Flow Range for High Viscosity Liquids



**Figure 5 Relationship between Viscosity and Coefficient of Maximum Flow Rate**



**Figure 2 Brodie Series 9900 Oval Flowmeter with Universal Mounting Box (UMB) Only**



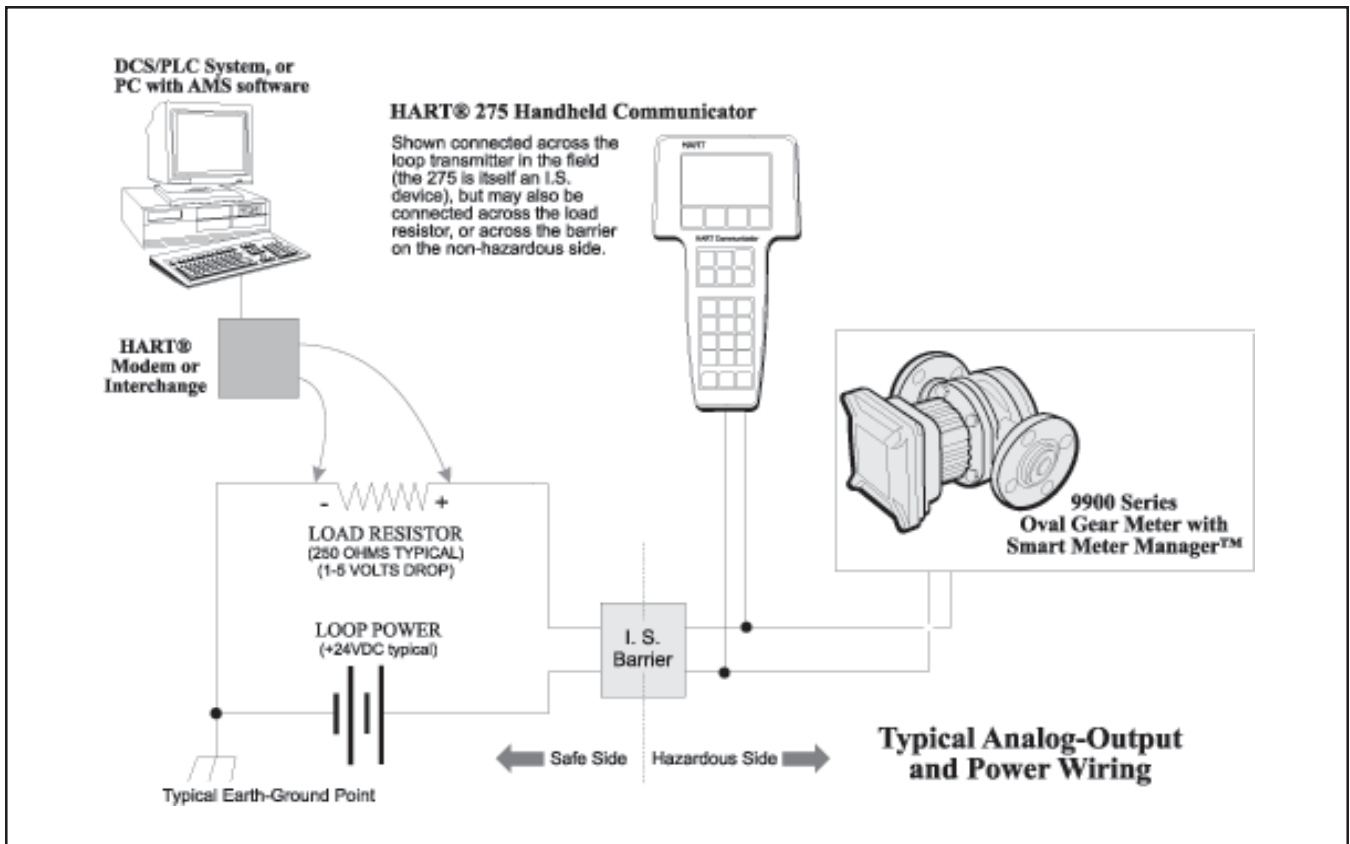

Figure 3 Typical Application: 9900 Series Oval Flowmeter with integral Smart Meter Manager

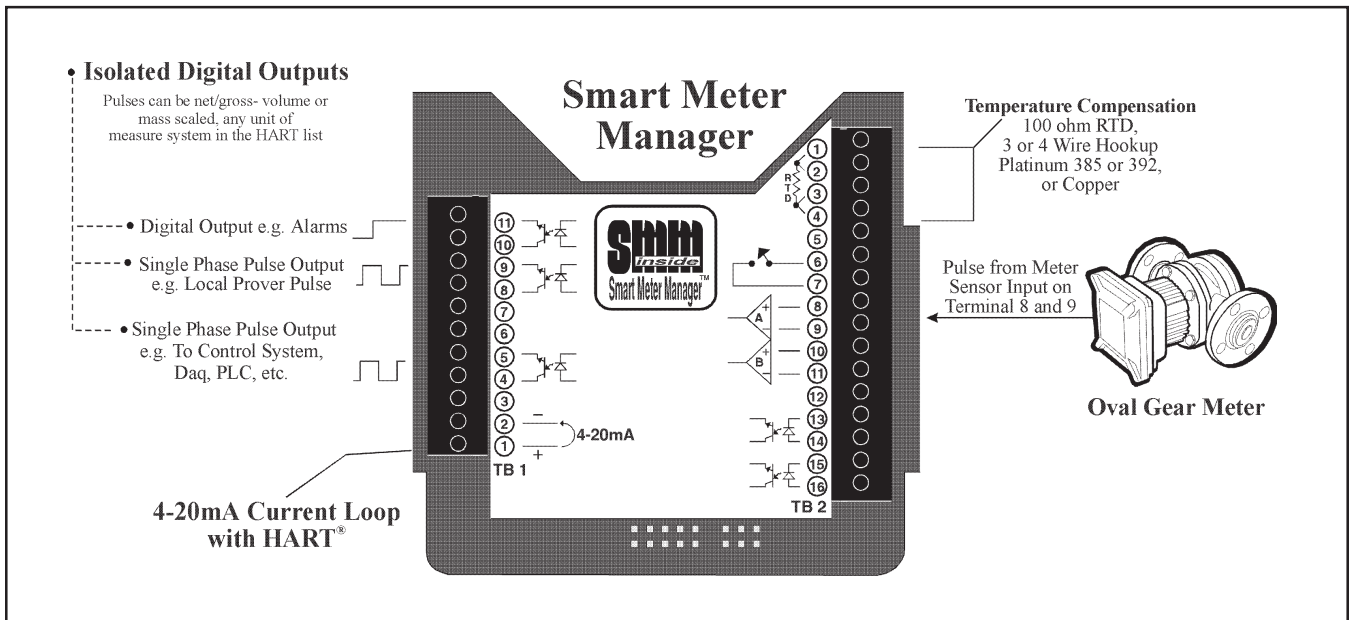

Figure 4 Typical Application: 9900 Series Oval Flowmeter with Smart Meter Manager™

The contents of this publication are presented for informational purposes only, and while every effort has been made to ensure their accuracy, they are not to be construed as warranties or guarantees, express or implied, regarding the products or services described herein or their use or applicability. Brodie Meter Co., LLC reserves the right to modify or improve the designs or specifications of such products at any time without notice.



19267 Highway 301 North (30461)  
PO Box 450 • Statesboro, GA 30459-0450  
Phone: (912) 489-0200 • Fax: (912) 489-0294  
www.brodieintl.com