

# Installation & Operation Manual

## **GF100 Series Metal Sealed, Thermal Mass Flow Controllers & Meters**

**BROOKS**<sup>®</sup>  
INSTRUMENT

*Beyond Measure*

## Essential Instructions Read before proceeding!

Brooks Instrument designs, manufactures and tests its products to meet many national and international standards. These products must be properly installed, operated and maintained to ensure they continue to operate within their normal specifications. The following instructions must be adhered to and integrated into your safety program when installing, operating and maintaining Brooks Instrument products.

- To ensure proper performance, use qualified personnel to install, operate, update, program and maintain the product.
- Read all instructions prior to installing, operating and servicing the product. If this instruction manual is not the correct manual, please see back cover for local sales office contact information. Save this instruction manual for future reference.

**▲ WARNING: Do not operate this instrument in excess of the specifications listed in the Instruction and Operation Manual. Failure to heed this warning can result in serious personal injury and / or damage to the equipment.**

- If you do not understand any of the instructions, contact your Brooks Instrument representative for clarification.
- Follow all warnings, cautions and instructions marked on and supplied with the product.

**▲ WARNING: Prior to installation ensure this instrument has the required approval ratings to meet local and national codes. Failure to heed this warning can result in serious personal injury and / or damage to the equipment.**

- Install your equipment as specified in the installation instructions of the appropriate instruction manual and per applicable local and national codes. Connect all products to the proper electrical and pressure sources.
- Operation: (1) Slowly initiate flow into the system. Open process valves slowly to avoid flow surges. (2) Check for leaks around the flow meter inlet and outlet connections. If no leaks are present, bring the system up to the operating pressure.
- Please make sure that the process line pressure is removed prior to service. When replacement parts are required, ensure that qualified people use replacement parts specified by Brooks Instrument. Unauthorized parts and procedures can affect the product's performance and place the safe operation of your process at risk. Look-alike substitutions may result in fire, electrical hazards or improper operation.
- Ensure that all equipment doors are closed and protective covers are in place to prevent electrical shock and personal injury, except when maintenance is being performed by qualified persons.

**▲ WARNING: For liquid flow devices, if the inlet and outlet valves adjacent to the devices are to be closed for any reason, the devices must be completely drained. Failure to do so may result in thermal expansion of the liquid that can rupture the device and may cause personal injury.**

### European Pressure Equipment Directive (PED)

All pressure equipment with an internal pressure greater than 0.5 bar (g) and a size larger than 25mm or 1" (inch) falls under the Pressure Equipment Directive (PED).

- The Specifications Section of this manual contains instructions related to the PED directive.
- Products described in this manual are in compliance with EN directive 2014/34/EU.
- All Brooks Instrument Flowmeters fall under fluid group 1.
- Products larger than 25mm or 1" (inch) are in compliance with PED category I, II or III.
- Products of 25mm or 1" (inch) or smaller are Sound Engineering Practice (SEP).

### European Electromagnetic Compatibility (EMC)

The Brooks Instrument (electric/electronic) equipment bearing the CE mark has been successfully tested to the regulations of the Electro Magnetic Compatibility (EMC directive 2014/30/EU).

Special attention however is required when selecting the signal cable to be used with CE marked equipment.

**Quality of the signal cable, cable glands and connectors:**

Brooks Instrument supplies high quality cable(s) which meets the specifications for CE certification.

If you provide your own signal cable you should use a cable which is overall completely screened with a 100% shield.

"D" or "Circular" type connectors used should be shielded with a metal shield. If applicable, metal cable glands must be used providing cable screen clamping.

The cable screen should be connected to the metal shell or gland and shielded at both ends over 360 Degrees.

The shield should be terminated to an earth ground.

Card Edge Connectors are standard non-metallic. The cables used must be screened with 100% shield to comply with CE certification.

The shield should be terminated to an earth ground.

For pin configuration : Please refer to the enclosed Instruction Manual.

### ESD (Electrostatic Discharge)

**▲ CAUTION: This instrument contains electronic components that are susceptible to damage by static electricity. Proper handling procedures must be observed during the removal, installation or other handling of internal circuit boards or devices.**

**Handling Procedure:**

1. Power to unit must be removed.
2. Personnel must be grounded, via a wrist strap or other safe, suitable means before any printed circuit card or other internal device is installed, removed or adjusted.
3. Printed circuit cards must be transported in a conductive container. Boards must not be removed from protective enclosure until immediately before installation. Removed boards must immediately be placed in protective container for transport, storage or return to factory.

**Comments**

This instrument is not unique in its content of ESD (electrostatic discharge) sensitive components. Most modern electronic designs contain components that utilize metal oxide technology (NMOS, SMOS, etc.). Experience has proven that even small amounts of static electricity can damage or destroy these devices. Damaged components, even though they appear to function properly, exhibit early failure.

## Section 1 General Information

Introduction .....	1
How to Use This Manual .....	1
Product Support References .....	2
Notice and Caution Statements .....	2
Product Warranty .....	2
How to Order a GF100 Series Device .....	2
Industry Standard References .....	2
GF100 Series Gas Table .....	2
Glossary of Terms and Acronyms .....	2
Description .....	5
Specifications for GF100 Series Devices .....	8

## Section 2 Installation

General .....	20
Receipt of Equipment .....	20
Recommended Storage Practice .....	20
Return Shipment .....	20
Transit Precautions .....	21
Removal from Storage .....	21
Gas Connections .....	21
In-Line Filter .....	21
Mechanical Installation .....	21
Flow Controller Installation Arrangement .....	22
Purge the Gas Supply Line Before GF100 Series Installation .....	23
Position and Mount the GF100 Series .....	24
Perform a Leak Test .....	26
Zeroing Setup Process .....	26
Zeroing the GF100 Series .....	26
Zeroing the GF100 Series Pressure Transducer from the LCD Display Panel .....	27
Zeroing GF100 Series Flow from LCD Display Panel .....	28
Performance Checks .....	28
Introduction to the MultiFlo™ Configurator .....	29
Using the MultiFlo Configurator .....	29
Electrical Connections .....	31
DeviceNet Connections .....	31
Analog/RS485 Connections .....	32
EtherCat Connections .....	33
GF135 Inlet Valve Installation .....	35
GF135 Commissioning .....	36

## Section 3 Operation

General .....	39
Theory of Operation for Flow Measurement .....	39

## Section 4 Maintenance & Troubleshooting

Overview .....	42
Maintenance .....	42
Troubleshooting .....	44
Troubleshooting Checklist .....	44
GF100 Series Troubleshooting Guide .....	45

## Section 5 Product Description Code

Overview .....	49
----------------	----

## Appendix A: GF100 Series Gas Table

Overview .....	57
----------------	----

## Appendix B: GF100 Series Patents

Overview .....	58
----------------	----

Warranty, Local Sales/Service Contact Information .....	Back Cover
---	------------

# Contents

## Figures

1-1	GF100 Series High Performance Gas Flow Controller Analog and Digital .....	1
1-2	LCD Display .....	7
1-3	Dimensions - GF100/GF120/GF125 Series .....	15
1-4	Dimensions - GF135, DeviceNet .....	16
1-5	Dimensions - GF135, RS485 .....	17
1-6	Dimensions - GF101/GF121/GF126 .....	18
1-8	Dimensions - GF100/GF120/GF125, GF101/GF121/GF126 Series with EtherCAT Communications	19
2-1	Typical Gas Supply Arrangement with Non-PTI MFC .....	22
2-2	Typical Gas Supply Arrangement with PTI MFC .....	22
2-3	GF100 Series Mounting Attitude Positions .....	24
2-4	GF100 Series Mounted to K1 Series Substrate Blocks .....	25
2-5	Mounting Screws Torque Pattern .....	25
2-6	Display with PSI Reading .....	27
2-7	Display Reading Zero PSI .....	27
2-8	Display Set to %FS .....	28
2-9	% Flow Display Set to Zero .....	28
2-10	MultiFlo Cable Adapter .....	30
2-11	USB-RS485 Converter (214F027AAA) .....	30
2-12	Diagnostic Port Locations .....	30
2-13	GF100 Series DeviceNet Connection .....	31
2-14	GF100 Series with 9-Pin Analog Connector .....	32
2-15	Analog 9-Pin Connector (M) .....	32
2-16	GF100 with EtherCat Communications, M8 Power Connector Location .....	33
2-17	M8 Power Connector Drawing .....	33
2-18	GF100 Series Electrical Interface Options .....	34
2-19	GF135 Series Showing Inlet/Outlet Pneumatic Isolation Valve Lines .....	35
3-1	GF100 Series Operating Principles .....	41

## Tables

1-1	Industry Standard References .....	3
1-2	Terms and Acronyms .....	4
1-3	Specifications for Standard GF100/GF120/GF125 Series .....	9
1-4	Specifications for Safe Delivery System (SDS) GF120 Series .....	10
1-3	Specifications for GF100/GF120/GF125 Series with EtherCAT Communications .....	11
1-6	Specifications for GF135 Series .....	12
1-7	Specifications for GF101/GF121/GF126 Series .....	13
1-8	Specifications for GF101/GF121/GF126 Series with EtherCAT Communications .....	14
2-1	K1 Series Fasteners .....	25
2-2	K1 Substrate Torque Data .....	25
2-3	Gas and Flow Ranges - MultiFlo Configurable - N2 Equivalent .....	29
4-1	Environmental Factors .....	44
4-2	GF100 Series Troubleshooting Guide .....	45
5-1	GF100, GF120 & GF125 Series Product Description Code .....	50
5-2	GF100, GF120 & GF125 Series with EtherCAT Communications Product Description Code .....	51
5-3	Model GF135 Product Description Code .....	52
5-4	GF101, GF121 & GF126 Series Product Description Code .....	53
5-5	GF101, GF121 & GF126 Series with EtherCAT Communications Product Description Code .....	54
A-1A	GF100 Series Gas Table - Codes 1-108, Bins SH40 to SH50 .....	56
A-1B	GF100 Series Gas Table - Codes 109-875, Bins SH40 to SH50 .....	57
A-1C	GF100 Series Gas Table - Codes 878-5022, Bins SH40 to SH50 .....	57
B-1	GF100 Series Patents .....	58

### Introduction

Designed for semiconductor, MOCVD, and other gas flow control applications that require a high purity all-metal flow path, the Brooks GF100 Series mass flow controllers and meters deliver outstanding performance, reliability, and flexibility. Process throughput and yield are maximized while process costs are reduced by the GF100 Series featuring:

- Ultra fast settling time for quick start up and very rapid process steps
- MultiFlo™ gas and range configurability enabling reconfiguration without removing device from the gas line
- An independent diagnostic/service port to troubleshoot or change flow conditions without removing the mass flow controller from service
- Long-term stability due to extremely low wetted surface area, and corrosion resistant Hastelloy® sensor and valve seat

Optional model variations including—pressure transient insensitivity (PTI) and Safe Delivery System (SDS)

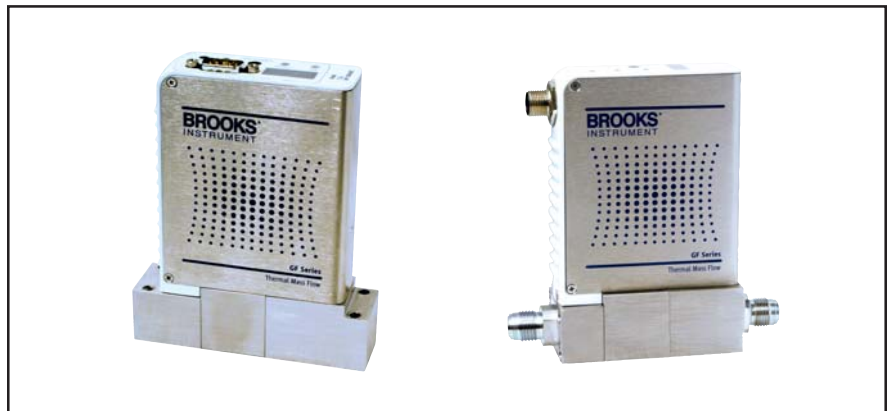

Figure 1-1 GF100 Series High Performance Gas Flow Controller Analog and Digital

### How to Use This Manual

This manual is intended to provide the user with all the information necessary to install, operate, troubleshoot and maintain these thermal mass flow devices. The manual is organized in the following sections:

Section 1 Introduction

Section 2 Installation

Section 3 Operation

Section 4 Maintenance and Troubleshooting

Section 5 Product Description Code

Appendix A GF100 Series Gas Table

Appendix B GF100 Series Patents

Appendix C Essential Instructions

Warranty, Local Sales/Service Contact Information

It is recommended that this manual be read in its entirety before attempting to operate or repair these devices.

## Section 1 Introduction

### Product Support References

Refer to [www.BrooksInstrument.com](http://www.BrooksInstrument.com) for Brooks sales and service locations and to obtain other documents that support the GF100 Series. Those documents include:

- Brooks MultiFlo™ Configurator Quick Start Manual:  
X-SW-MultiFlo-Config-QS-eng. part Number 541B167AAG
  
- Brooks GF100 Series data sheets:  
DS-TMF-GF100-Series-MFC-eng  
DS-TMF-GF135-Series-MFC-eng  
DS-TMF-GF121-Series-MFC-eng  
DS-DPT-EtherCAT-GF100-Series-eng

### Notice and Caution Statements

Warning, caution and notice statements are located throughout this manual in the ANSI format. A WARNING statement indicates a potentially hazardous situation which, if not avoided, COULD result in death or serious injury. A CAUTION statement indicates a potentially hazardous situation which, if not avoided, MAY result in minor or moderate injury. It may also be used to alert against unsafe practices. A NOTICE statement describes specific information that requires special attention.

### Product Warranty

Product warranty information can be found on the Back Cover of this Manual and on the Brooks website at [www.BrooksInstrument.com](http://www.BrooksInstrument.com). This information provides general warranty information, limitations, disclaimers, and applicable warranty periods according to product group.

### How to Order a GF100 Series Device

Refer to Section 5.

### Industry Standard References

Refer to Table 1-1.

### GF100 Series Gas Table

Refer to Appendix A.

### Glossary of Terms and Acronyms

Refer to Table 1-2

Table 1-1 Industry Standard References

Reference Number	Reference Description
MIL-STD-810	Method 514.4, Category 1, Transportation Requirement Method 516.4, Procedure 1, Functional Shock Test Requirement
SEMI E12	Standard temperature and pressure
SEMI E16	Guideline for determining and describing MFC leak rates
SEMI E17	Guideline for MFC transient characteristics tests
SEMI E18	Guideline for temperature specifications of the MFC
SEMI E27	Standard for MFC and MFM linearity
SEMI E28	Guideline for pressure specifications for the MFC
SEMI E52	Practice for referencing gases used in digital MFCs
SEMI E54	Sensor actuator network connections for DeviceNet
SEMI E56	Test method for determining accuracy, linearity, repeatability, short-term reproducibility, hystereses of thermal MFCs
SEMI E66	Test method for determining particle contribution by MFCs
SEMI E67	Test method for determining reliability of MFCs
SEMI E68	Test method for determining warm-up time of MFCs
SEMI E69	Test method for reproducibility and zero drift for thermal MFCs
SEMI E80	Test method for determining attitude sensitivity of MFCs
SEMI E16-90	Guidelines for determining and describing mass flow controllers leak rates
SEMI F19	Specification for the finish of the wetted surface of electro polished 216L stainless steel components
SEMI F20	Specifications for 316L stainless steel bar, extruded shapes, plate, and investment castings for components used in ultra-high purity semi manufacturing applications
SEMI F36	Guide for dimensions and connections of gas distribution components
SEMI F37	Method for determination of surface roughness parameters for gas distribution system components
SEMI F44	Guideline for standardization of machined stainless steel weld fittings
SEMI F45	Guideline for standardization of machined stainless steel reducing fittings
SEMI F47	Specifications for semiconductor processing equipment voltage sag immunity
SEMI S2	Environmental, Health and Safety Guidelines
SEMI S9	Dielectric testing
SEMI S10	Risk assessment
SEMI S12	Decontamination of fielded products
ETG.1000.2	Physical Layer service definition and protocol specification
ETG.1000.3	Data Link Layer service definition
ETG.1000.4	Data Link Layer protocol specification
ETG.1000.5	Application Layer service definition
ETG.1000.6	Application layer protocol specification
ETG.1020	EtherCAT Protocol Enhancements
ETG.2000	EtherCAT Slave Information
ETG.5001.1	Modular Device Profile - Part 1: General MDP Device Model
ETG.5003.1	Semiconductor Device profile - Part 1: Common Device Profile (CDP)
ETG.5003.2020	Specific Device Profile: Enhanced Mass Flow Controller
ETG.5003.2021	Specific Device Profile: Mass Flow Controller
ETG.5003.2022	Specific Device Profile: Mass Flow Meter
ETG.5003.2023	Specific Device Profile: Enhanced Mass Flow Meter

## Section 1 Introduction

Table 1-2 Terms and Acronyms

Term or Acronym	Definition
CSR	Customer Special Requirement
CVD	Chemical Vapor Deposition
DeviceNet	A 5-wire local network I/O communication device that employs a command/response communication protocol
DSP	Digital Signal Processor
EPI Epitaxy (EPI).	A process technology where a pure silicon crystalline structure is deposited or “grown” on a bare wafer, enabling a high-purity starting point for building the semiconductor device.
HBD	Horizontal Base Down
GF100 Series	Integrated Flow Controller
F.S.	Full Scale
LED	Light Emitting Diode
MFC	Mass Flow Controller
MultiFlo Configurator	I/O communication software package that configures gas and flow ranges
MultiFlo Technology	A physics-based calibration methodology that enables gas and flow range configuration within a defined standard configuration
PID	Proportional Integral Derivative Controller
PSIA	Pounds per Square Inch Absolute
PSID	Pounds per Square Inch Differential
PSIG	Pounds per Square Inch Gauge
PTI	Pressure Transient Insensitive. Reduces the effect of pressure fluctuations in gas flow. Applicable to GF125 only.
ROR	As pressure increases, flow increases at a pressure rate of rise, or ROR.
HC	Standard Configuration w/ Hastelloy® sensors (to reduce reaction to corrosive gases)
S.P.	Setpoint
Step Technology	Enables fast set point control through a high speed DSP and low volume drive circuit
VIU	Vertical mounting attitude with inlet side facing up



## Description

**Ultra Fast Response**

The Brooks GF Series patented flow sensor combined with a high speed ARM processor and fast acting diaphragm-free valve assembly enables:

- Faster response and settling time for improved wafer throughput
- Ultra-fast 1-2 second etch step processing
- Reduced diverted gas consumption and associated abatement costs
- Time sensitive gas delivery steps in Atomic Layer Deposition
- User programmable start-up function for processes requiring a slow ramped gas turn-on or time critical transitions between flow rates

**MultiFlo™ Gas and Range Configurability**

The Brooks MultiFlo technology delivers exceptional improvement in process gas accuracy for linear and non-linear gases. This is achieved through advanced gas modeling and optimized through actual gas testing. Brooks MultiFlo™ allows the device to be quickly and easily configured for another gas and/or flow range without sacrificing accuracy or rangeability. Selecting a new gas automatically creates a new calibration curve, establishes optimized PID settings for dynamic control, automatically compensates for gas density effects, and ensures smooth overshoot-free transitions between flow rates with excellent steady-state stability. Brooks MultiFlo technology offers unparalleled flexibility. An extensive gas database is provided and a single device can be quickly programmed for thousands of different gas and flow range combinations. Process benefits achieved:

- Mass flow controller full scale full range can be rescaled down typically by a factor of 3:1 with no impact on accuracy, turndown or leak by specifications
- Optimum process and inventory flexibility resulting in dramatically reduced inventory costs
- Fewer configurations/bin sizes required to support many different processes
- Less down-time with rapid process recovery

**MultiFlo™ Support References:** Brooks MultiFlow Configurator Quick Start Guide (X-SW-MultiFlo-Config-QS-eng (Part Number: 541B167AAG))

**MultiFlo™ Configurator Accessory Kits:****778Z010ZZZ Basic MultiFlo Configurator Kit**

\*Software, MultiFlo Configurator

A331710003 Cable Assembly 2.5mm

214F027AAA USB-RS485 Converter with DB-9 female

**778Z011ZZZ Basic MultiFlo Configurator Kit w/Power Supply and Adapter Cables** \*Software, MultiFlo Configurator

A331710003 Cable Assembly 2.5mm

214F027AAA USB-RS485 Converter with DB-9 female

A332295001 Power Supply MFC

A332297002 Cable, Power, 9-Pin

A332297001 Cable, Power, DeviceNet

\* MultiFlo Configurator Software is available on the Brooks Instrument website at: [www.BrooksInstrument.com/MultiFlo](http://www.BrooksInstrument.com/MultiFlo)

[www.BrooksInstrument.com/Documentation&Downloads](http://www.BrooksInstrument.com/Documentation&Downloads)

## Section 1 Introduction

### **Pressure Transient Insensitivity (PTI)— Included with all GF125 & GF135 models**

Cost and space constraints are driving gas panel designers to remove point-of-use pressure regulators and pressure monitoring components from the process design and rely solely on the mass flow controller to accurately control the process under dynamic pressure conditions. The Brooks GF125 & GF135 (PTI) devices utilize a patented control algorithm that inverts the pressure signal, compares it to the pre-fluctuation signal and drives real-time valve position compensation to maintain stable flow. Enhanced pressure transient is achieved through faster sensing, quicker processing, and a reduction in internal dead-volume between the sensors and valve orifice.

### **GF101/121/126 based on the same technology and design as the low flow GF's (same sensor, same electronics, low power support)**

- Smaller footprint than competitive MFC's
- Handles flow rates up to 300 slpm
- Metal seal for durability and high leak integrity
- Proprietary sensor technology
- Precise flow control with fast sub-1 second settling time
- 1% of reading accuracy
- Corrosion-resistant Hastelloy C-22 sensor tube

### **Optional Safe Delivery System (SDS)— GF120 model only**

The Safe Delivery System (SDS) enhanced GF120 model is a state-of-the-art low pressure drop devices for the delivery of sub atmospheric safe delivery system gases used in Implant and Etch processes. The Brooks GF120 SDS models are available in full scale flow ranges 4 sccm -1 slpm.

### **Advanced Thermal Flow Measurement Sensor**

Brooks proprietary highly corrosion resistant Hastelloy C-22 sensor with an enhanced sensor manufacturing and burn in process incorporates a unique orthogonal sensor mounting orientation to eliminate sensor drift caused by valve heating effects and eliminates thermal siphoning effects. This unique sensor configuration includes an optimized temperature profile for gases prone to thermal decomposition. This design results in:

- Enhanced signal to noise performance for improved accuracy at low set points
- Superior reproducibility at elevated temperature through new isothermal packaging and onboard conditioning electronics with ambient temperature sensing and compensation
- Improved long-term stability

### High Purity Flow Path

The Brooks GF Series has an all metal, corrosion resistant Semi F20 compliant wetted flow path with highly corrosion resistant Hastelloy C-22 valve seat and jet orifice. The GF120, GF125 & GF135 devices are constructed with a 4 $\mu$  inch Ra max surface finish while the GF100 is constructed with a 10 $\mu$  inch Ra.

- Overall reduced surface area and un-swept volumes for faster dry-down during purge steps
- Long-term sensor and device stability for maximum yield and throughput

### Extensive Mechanical Configurations

GF Series supports all metal seal/UHP industry gas connection interface standards for full OEM and process coverage.

- Downport 79.8mm and 92mm C-seal and W-seal on 1-1/8" and 1-1/2" bodies
- 124mm 4 VCR on 1-1/2" body



Figure 1-2 LCD Display

### Enhanced Diagnostics and User Interface

The mass flow controller is one of the most complex and critical components in gas delivery systems. When dealing with ultra-high-purity gas distribution or highly toxic or corrosive gases, removing the mass flow controller to assess functionality should be the last resort. Brooks GF Series devices provide for in-line device evaluation and instantaneous troubleshooting through:

- Embedded self test routines and independent diagnostic/service port
- High visibility LCD display with easy accessible push button for local indication of Flow (%), Temperature ( $^{\circ}$ C), Pressure (PSIA/kPa) and Network Address
- Zero button to easily re-zero the device during scheduled maintenance
- Rotatable display with a push button to enable improved readability based on how the MFC is mounted. Simply hold button down for at least 3 seconds to rotate display. This feature is standard for GF135 and GF101/ GF121/GF126 and available for GF100/GF120/GF125.

This combination of features results in limiting service interruption and reduced downtime.

## Section 1 Introduction

### Communication Interfaces

The GF100 Series supports analog 0-5 Vdc, RS485, DeviceNet™ and EtherCAT® communication protocols. Analog connections can be accessed via the DeviceNet or RS485 or Analog only connector options. DeviceNet and RS485 are multi-drop connections that allow a maximum of 64 devices for DeviceNet and 32 devices for RS485 to be connected on the same network. Brooks Instrument's DeviceNet profile has been certified by the ODVA™ (Open DeviceNet Vendor's Association). EtherCAT is an Ethernet based communications system known for its high cycle time and cost efficient cabling and master application solutions. The EtherCAT GF100 Series devices conform to the ETG.5003 Semiconductor Device Profile specification. A range of low profile adapter cables facilitate replacing previously installed devices eliminating the need to carry multiple devices of the same gas/range but different electrical connectors.

### Specifications for GF100 Series Devices

#### **WARNING**

**Do not operate this instrument in excess of the specifications listed below. Failure to heed this warning can result in serious personal injury and/or damage to the equipment.**

#### **CAUTION**

**It is the user's responsibility to select and approve all materials of construction. Careful attention to metallurgy, engineered materials and elastomeric materials is critical to safe operation.**

See Table 1-3 for specifications for standard GF100 Series.

See Table 1-4 for specifications for the Safe Delivery System (SDS) GF120 Series.

See Table 1-5 for specifications for standard GF100 Series-EtherCAT

See Table 1-6 for specifications for the GF135 Series.

See Table 1-7 for specifications for the GF121 Series.

See Table 1-8 for specifications for the GF121 Series-EtherCAT

See Figure 1-3 for dimensions for the GF100 Series.

See Figures 1-4 & 1-5 for dimensions for the GF135 Series.

See Figure 1-6 for dimensions for the GF121 Series.

See Figure 1-7 for dimensions for the GF100/GF121 Series-EtherCAT

Table 1-3 Specifications for Standard GF100/GF120/GF125 Series

Performance	GF100	GF120	GF125
Full Scale Flow Range (N <sub>2</sub> Eq.)	3 sccm to 55 slm		
Flow Accuracy	±1% S.P. > 35-100%, ±0.35% F.S. 2-35%		
Repeatability & Reproducibility	< ± 0.15% S.P.		
Linearity	± 0.5% F.S. (included in accuracy)		
Response Time (Settling Time) Normally Closed Valve	< 1 sec	700ms	300ms (3-860 sccm N <sub>2</sub> Eq.) 400ms (861-7200 sccm N <sub>2</sub> Eq.) 500ms (7201-30000 sccm N <sub>2</sub> Eq.) <700ms (30001-55000 sccm N <sub>2</sub> Eq.)
Normally Open Valve	<1.5 sec		
Pressure Insensitivity	Not Applicable		< 5% SP up to 5 psi/sec upstream press. spike
Control Range	2-100% (Normally Closed Valve)	3-100% (Normally Open Valve)	
MultiFlo	standard		
#of Bins	11 bins		
Valve Shut Down (N.C. Valve)	< 1% of F.S.		
Valve Shut Down (N.O. Valve)	2% of F.S.		
Zero Stability	< ± 0.5% F.S. per year		
Temperature Coefficient	Span: 0.05% S.P. per °C, Zero: 0.005% F.S. per °C		
<b>Ratings</b>			
Operating Temperature Range	10-50°C		
Differential Pressure Range*	3-860 sccm = 7-45 psid, 861- 7200 sccm = 10-45 psid, 7201-55000 sccm = 15-45 psid *Argon gas applications require an additional 10 psid differential pressure. Low vapor pressure gases require an inlet pressure of > 100 Torr, with vacuum on outlet (example SiCl <sub>4</sub> ). Contact Brooks Technical Support for more information.		
Maximum Operating Pressure	500 psia max	100 psia max	
Leak Integrity (external)	1x10 <sup>-10</sup> atm. cc/sec He		
<b>Mechanical</b>			
Valve Type	Normally Closed Normally Open Meter (no valve)		
Wetted Materials	GF100: SEMI F20 HP Compliant, 316L VIM/VAR, Hastelloy C-22, 316L Stainless Steel, 304 Stainless Steel, KM-45 GF120/GF125: SEMI F20 UHP Compliant, 316L VIM/VAR, Hastelloy C-22, 316L Stainless Steel, 304 Stainless Steel, KM-45		
Surface Finish	10µ inch Ra	4µ inch Ra (0.1 µm Ra)	
<b>Diagnostics &amp; Display</b>			
Status Lights	MFC Health, Network Status		
Alarms	Control Valve Output, Network Interruption		
Display Type Viewing Angle / Viewing Distance Units Displayed / Resolution	Top Mount Integrated LCD Fixed / 10 feet Flow (%), Temp. (°C), Pressure (psia, kPa) / 0.1 (unit)		
<b>Electrical</b>			
Electrical Connection	RS485/Analog via 9-Pin "D" connector, DeviceNet™ via 5-Pin "M12" connector		
Digital Communication	RS485+ (model specific), DeviceNet (model specific), RS485 Diagnostic Port (all models)		
Diagnostic /Service Port	RS485 via 2.5mm jack		
Power Supply/Consumption	DeviceNet: 545mA max. @ +11-25 Vdc., 250mA max. @ 24Vdc RS485/Analog: 6 Watts max @ ±15Vdc. (±10%) or +24 Vdc (±10%)		
<b>Compliance</b>			
EMC	EC Directive 2004/108/EC CE: EN61326: 2006 (FCC Part 15 & Canada IC-subset of CE testing)		
Environmental Compliance	RoHS Directive (2011/65/EU) REACH Directive EC 1907/2006		

NOTE: See the following Safe Delivery System (SDS) section for optional detailed specifications

## Section 1 Introduction

Table 1-4 Specifications for Safe Delivery System (SDS) GF120 Series

Performance	GF120XSL	GF120XSD
Full Scale Flow Range (N <sub>2</sub> Eq.)	4 - 25 sccm	>25 to 1 slpm
Gases Supported	AsH <sub>3</sub> , PH <sub>3</sub> , BF <sub>3</sub> , SiF <sub>4</sub> , Ar, Xe, N <sub>2</sub> O, N <sub>2</sub> , GeF <sub>4</sub> , AsF <sub>5</sub> , PF <sub>3</sub> , H <sub>2</sub> Se, HMDSO, HMDSN, H <sub>2</sub> O***	
MultiFlo Programmable	Not Configurable	
Flow Accuracy	+/-1% S.P. ≥35% F.S. +/-0.35% F.S. <35% F.S.	
Repeatability & Reproducibility	<+/- 0.15% S.P.	
Zero Stability	<=0.6% F.S. per year	
Settling Time (to within ±2% F.S.)	< 3 sec	
Warm Up Time	minimum of 30 minutes	
Leak Integrity	1X10 <sup>-11</sup> atm. cc/sec He	
Valve Shut Down (Leaky by)	<1% F.S.	

Operating Conditions	GF120XSD	GF120XSL
Minimum Operating Inlet Pressure*	4 to 20 sccm ≤ 10 Torr >20 to 50 sccm ≤ 20 Torr >50 sccm to 1 slpm ≤ 50 Torr	
Maximum Pressure	500 psia max	
Pressure Insensitivity	Not Available	
Differential Pressure**	10 Torr-30 psid typical (1.33-207 kPa typical)	
Valve Configuration	Normally Closed	
Ambient Temperature Range	10°C-50°C	
Zero Temperature Coefficient	Span: 0.05% SP per °C, Zero: 0.005% F.S. per °C	

\*Performance at minimum inlet pressure will be gas and flow range dependent. Consult Technical Support for details.

\*\*Typical pressure drop. Actual pressure drop will be gas and flow dependent. Consult Technical Support for details.

\*\*\*Consult factory for other gases.

Table 1-5 Specifications for GF100/GF120/GF125 Series with EtherCAT Communications

Performance	GF100	GF120	GF125	GF120XSL	GF120XSD
Full Scale Flow Range	3 sccm to 55 slm			4 sccm to 25 sccm	>25 sccm to 1 slpm
Flow Accuracy	±1% S.P. > 20-100%; ±0.2% F.S. 2-20%			±1% S.P. 35-100%; ±0.35% F.S. 2-35%	
Repeatability & Reproducibility	< ± 0.15% S.P.				
Flow Settling Time (NC Valve)	< 1 sec	700ms	300ms (3-860 sccm N2 Eq.) 400ms (861-7200 sccm N2 Eq.) 500ms (7201-30000 sccm N2 Eq.) <700ms (30001-55000 sccm N2 Eq.)	< 3 sec	
Flow Settling Time (NO Valve)	<1.5 sec			-----	
Pressure Insensitivity	Not Applicable		< 1% S.P. up to 5 psi/sec upstream press. spike	-----	
Control Range	2-100% (Normally Closed Valve) 3-100% (Normally Open Valve)			2-100% (Normally Closed Valve)	
MultiFlo	Standard			-----	
#of Bins	11 bins			-----	
Valve Shut Down (N.C. Valve)	0.15% of F.S.			<1% of F.S.	
Valve Shut Down (N.O. Valve)	2% of F.S.			-----	
Zero Stability	< ± 0.15% F.S. per year			< ± 0.6% F.S. per year	
Temperature Coefficient	Zero: 0.005% F.S. per °C			Zero 0.005% of F.S. per °C	

**Ratings**

Operating Temperature Range	10-50°C				
Differential Pressure Range*	3-860 sccm = 7-45 psid 861- 7200 sccm = 10-45 psid 7201-55000 sccm = 15-45 psid			10 Torr - 30 psid typical For more details consult factory	
Maximum Operating Pressure	500 psia max		100 psia max	up to 500 psia max	
Leak Integrity (external)	1x10 <sup>-10</sup> atm. cc/sec He				

**Mechanical**

Valve Type	Normally Closed Normally Open Meter (no valve)			Normally Closed	
Wetted Materials	SEMI F20 HP Compliant, 316L VIMVAR, Hastelloy C-22, 316L Stainless Steel, 304 Stainless Steel, KM-45				
Surface Finish	10μ inch Ra	5μ inch Ra		5μ inch Ra	

**Diagnostics & Display**

Status Lights	Run, Error, Power, Network Status				
Alarms	Control Valve Output, Network Interruption, Temperature High/Low, Pressure High/Low, Power Surge/Sag				
Display Type	Top Mount Integrated LCD				
Viewing Angle / Viewing Distance	Rotatable / 10 feet				
Units Displayed / Resolution	Flow (%), Temp. (°C), Pressure (psia, kPa) / 0.1 (unit)				

**Electrical**

Electrical Connection	Power via 5-pin M8 Connector, EtherCAT via RJ45 jacks				
Digital Communication	EtherCAT				
Diagnostic /Service Port	Micro-USB				
Power Supply/Consumption	320 mA max. @ 18-30 Vdc, 230 mA max. @ 24 Vdc (under typical operating conditions)				

**Compliance**

EMC	EMC Directive 2014/30/EU Evaluation Standard EN61326-1:2013				
Environmental Compliance	RoHS Directive (2011/65/EU) REACH Directive EC (1907/2006)				

\*Argon gas applications require an additional 10 psid differential pressure. Low vapor pressure gases require an inlet pressure of > 100 Torr, with vacuum on outlet (example SiCl<sub>4</sub>). Contact Brooks Technical Support for more information.

## Section 1 Introduction

Table 1-6 Specifications for GF135 Series

### Performance

<b>Full Scale Flow Range:</b>	3 sccm to 5 slm (N2 Eq.)
<b>Gasses Supported:</b>	N2, O2, Ar, H2, SF6, NH3, CO2, Cl2, HBr, NF3, CF4, CH4, CH3F, CH2F2, SiCl4 (@ 100 Torr), C4F6-q (@ 800 Torr), C4F8 (@ 1200 Torr), N2O, CHF3, SiH2Cl2, C5F8, He
<b>Flow Accuracy:</b>	+/-1.0% S.P. (10-100% F.S.), +/-1% S.P. plus +/-0.04% F.S. (2-10% F.S.)
<b>Repeatability &amp; Reproducibility:</b>	< +/- 0.15% S.P.
<b>Linearity:</b>	Included in accuracy
<b>Settling Time (to within +/-2% FS):</b>	<300ms (<860 sccm N2 Equivalent), <400ms (861-5000 sccm N2 Equivalent)
<b>Pressure Insensitivity:</b>	< 1% S.P. up to 5 psi/sec upstream press. spike
<b>Control Range:</b>	1-100%
<b>Valve Shut Down:</b>	< 0.5% of F.S. N2
<b>Zero Stability:</b>	< +/- 0.5% F.S. per year
<b>Temperature Coefficient:</b>	Span: 0.05% setpoint per °C, Zero: 0.005% F.S. per °C
<b>Rate-of-Decay Performance:</b>	(ROD by default is disabled/off. It should not be enabled until after MFC is installed and properly commissioned)
<b>Flow Rate:</b>	Maximum flow rate for which an ROD measurement can be obtained is 800 sccm
<b>Temperature Sensitivity:</b>	+/- 0.04% S.P./Deg C
<b>Pressure Sensitivity:</b>	+/- 0.04% F.S./psi
<b>Minimum Detectable Change from Commissioning Baseline:</b>	Zero Drift: +/- 0.02% F.S. Valve Leak: +0.1% F.S. Repeatability: +/- 0.3% S.P. (SiCl4 +/- 0.5% from 5-100% S.P. up to 100 sccm flow)

### Ratings

<b>Operating Temperature Range:</b>	10-50°C
<b>Differential Pressure Range**:</b>	3-860 sccm = 7-45 psid, 861- 5000 sccm = 10-45 psid **Typical pressure drop. Actual pressure drop will be gas and flow dependent. Argon gas applications require higher differential pressure. Low vapor pressure gases require an inlet pressure of > 100 Torr, with vacuum on outlet (example SiCl4). Contact Brooks Technical Support for more information.
<b>Maximum Operating Pressure:</b>	100 psia max
<b>Pneumatic Valve Operating Pressure:</b>	43.5 psia - 72.5 psia
<b>Leak Integrity (external):</b>	1x10-10 atm. cc/sec He

### Mechanical

<b>Valve Type:</b>	Normally Closed
<b>Wetted Materials:</b>	SEMI F20 UHP Compliant 316L VIM/VAR, Hastelloy C-22,316L Stainless Steel, 304 Stainless Steel, KM-45
<b>Surface Finish:</b>	4µ inch Ra (0.1 µm Ra)

### Diagnostics & Display

<b>Status Lights:</b>	MFC Health, Network Status
<b>Alarms:</b>	Sensor Output, Control Valve Output, Over Temperature, Power Surge/Sag, Network Interruption, Sensor Drift, Flow Error, Valve Leak
<b>Display Type:</b>	Top Mount Electronically Rotatable Integrated LCD
<b>Viewing Distance:</b>	Fixed / 10 feet
<b>Units Displayed / Resolution:</b>	Flow (%), Temp. (°C), Pressure (psia, kPa) / 0.1 (unit)

### Electrical

<b>Electrical Connection:</b>	Analog/RS-485 via 9-Pin "D" connector, DeviceNet via 5-Pin "M12" connector
<b>Digital Communication:</b>	RS485+ (model specific), DeviceNet (model specific), RS485 Diagnostic Port (all models)
<b>Diagnostic / Service Port:</b>	RS485 via 2.5 mm jack
<b>Power Supply/Consumption:</b>	DeviceNet: +11-25 Vdc., 545 mA max. @ 11 Vdc., 250 mA (max.) @ 24 Vdc., Analog /RS485: +/-15 Vdc. (+10%), 6 Watts (max) or +24 Vdc +/-10%

### Compliance

<b>EMC</b>	EC Directive 2004/108/EC CE: EN61326: 2006 (FCC Part 15 & Canada IC-subset of CE testing)
<b>Environmental Compliance</b>	RoHS Directive 2011/65/2006 Reach Directive EC 1907/2006

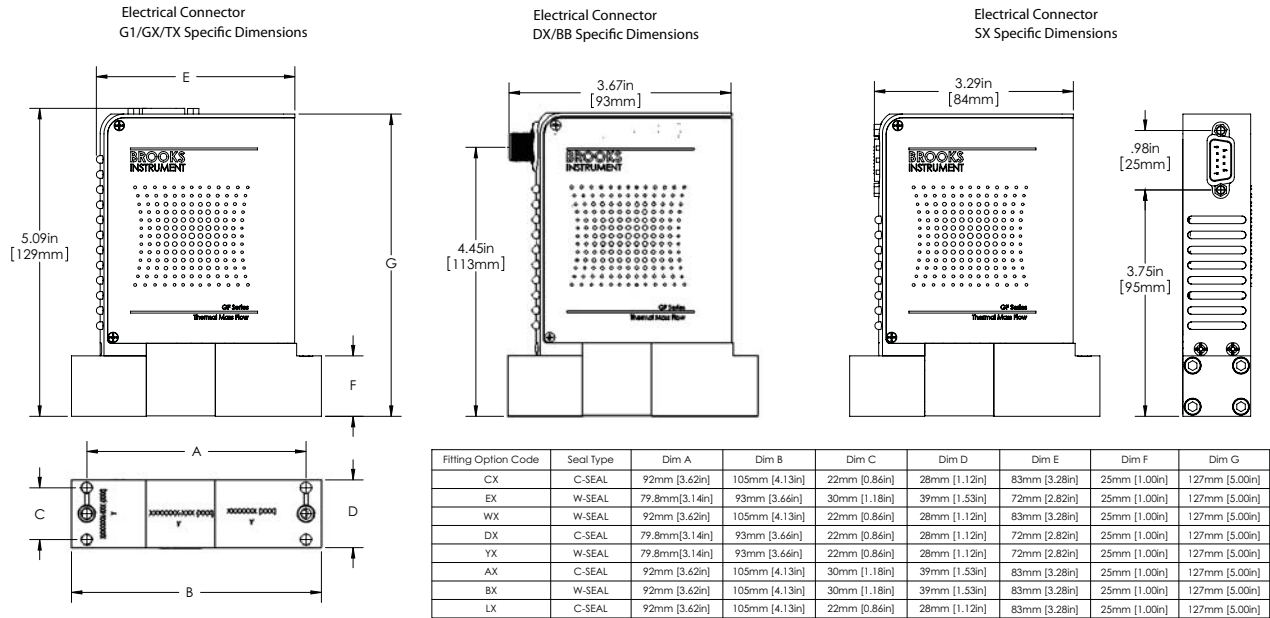

Table 1-7 Specifications for GF101/GF121/GF126 Series

Performance	GF101	GF121	GF126
Full Scale Flow Range (N <sub>2</sub> Eq.)	55 to 300 slm		
Flow Accuracy	±1% S.P. > 35-100%, ±0.35% F.S. 2-35%		
Repeatability & Reproducibility	< ± 0.15% S.P.		
Linearity	± 0.5% F.S. (included in accuracy)		
Response Time (Settling Time) Normally Closed Valve	< 1 sec		
Pressure Transducer			Ability to measure inlet pressure
Control Range	5-100% (Normally Closed Valve)		
MultiFlo	Standard (All typical high flow rate process gases & mixtures supported)		
# of Bins	4 Bins		
Control Range	5-100% (Normally Closed Valve)		
Valve Shut Down (N.C. Valve)	< 2% of F.S. @ 30 N <sub>2</sub> psig/atm out		
Zero Stability	< ± 0.5% F.S. per year		
Temperature Coefficient	Span: 0.05% S.P. per °C, Zero: 0.005% F.S. per °C		
<b>Ratings</b>			
Operating Temperature Range	10-50°C		
Differential Pressure Range	30-90 psid		
Maximum Operating Pressure	Controller: 75 psig / Meter: 150 psig		
Leak Integrity (external)	1x10 <sup>-10</sup> atm. cc/sec He		
<b>Mechanical</b>			
Valve Type	Normally Closed Meter (no valve)		
Wetted Materials	GF101: SEMI F20 HP Compliant, 316L VIMVAR, Hastelloy C-22, 316L Stainless Steel, 304 Stainless Steel, KM-45 GF121/GF126: SEMI F20 UHP Compliant, 316L VIMVAR, Hastelloy C-22, 316L Stainless Steel, 304 Stainless Steel, KM-45		
Surface Finish	10µ inch Ra	5µ inch Ra (0.1 µm Ra)	
<b>Diagnostics &amp; Display</b>			
Status Lights	MFC Health, Network Status		
Alarms	Control Valve Output, Network Interruption		
Display Type Viewing Angle / Viewing Distance Units Displayed / Resolution	Top Mount Integrated LCD Fixed / 10 feet Flow (%), Temp. (°C), Pressure (psia, kPa) / 0.1 (unit)		
<b>Electrical</b>			
Electrical Connection	RS485/Analog via 9-Pin "D" connector, DeviceNet™ via 5-Pin "M12" connector		
Digital Communication	RS485+ (model specific), DeviceNet (model specific), RS485 Diagnostic Port (all models)		
Diagnostic /Service Port	RS485 via 2.5mm jack		
Power Supply/Consumption	DeviceNet: 545 mA max. @ +11-25 Vdc., 250mA max. @ 24 Vdc (Under typical operating conditions) RS485/Analog: 6 Watts max @ ±15 Vdc. (±10%) (Under typical operating conditions)		
<b>Compliance</b>			
EMC	EC Directive 2004/108/EC CE: EN61326: 2006 (FCC Part 15 & Canada IC-subset of CE testing)		
Environmental Compliance	RoHS Directive (2011/65/EU) REACH Directive EC 1907/2006		



Downport Configurations



VCR Configurations

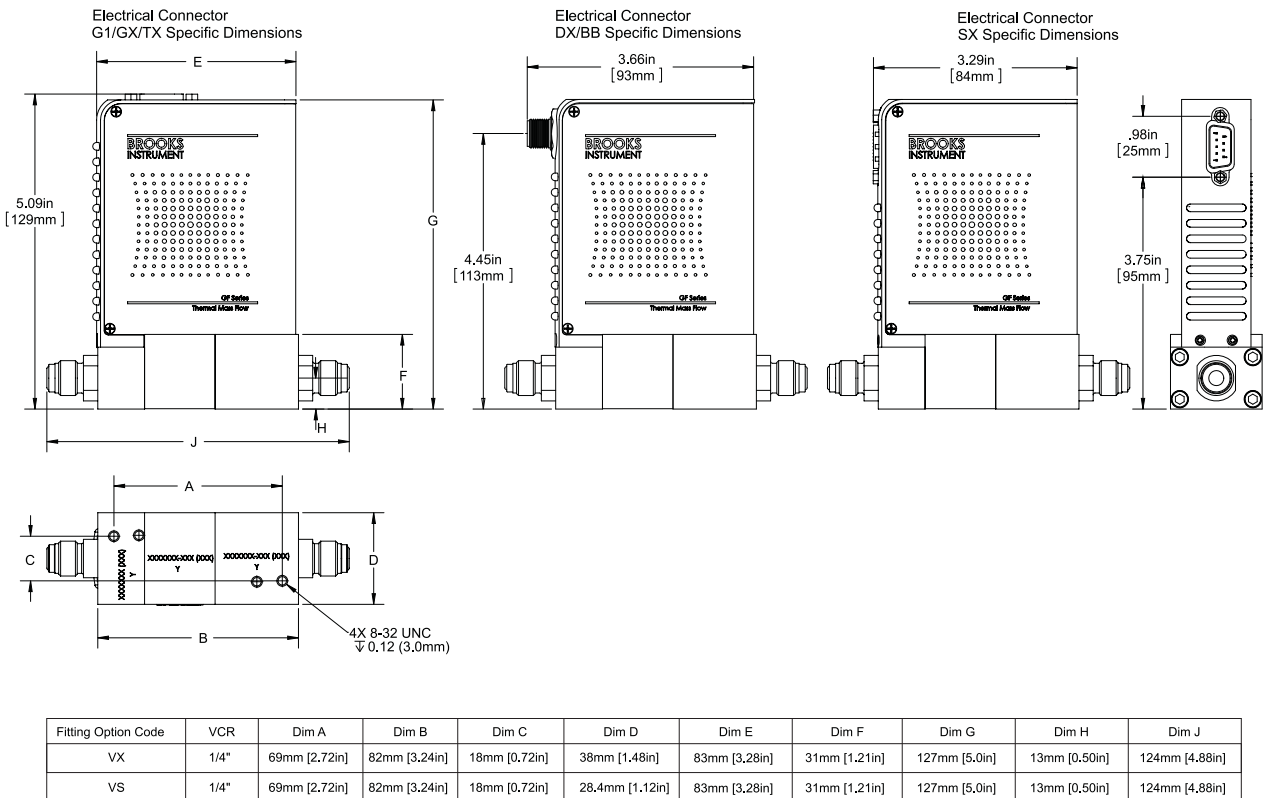
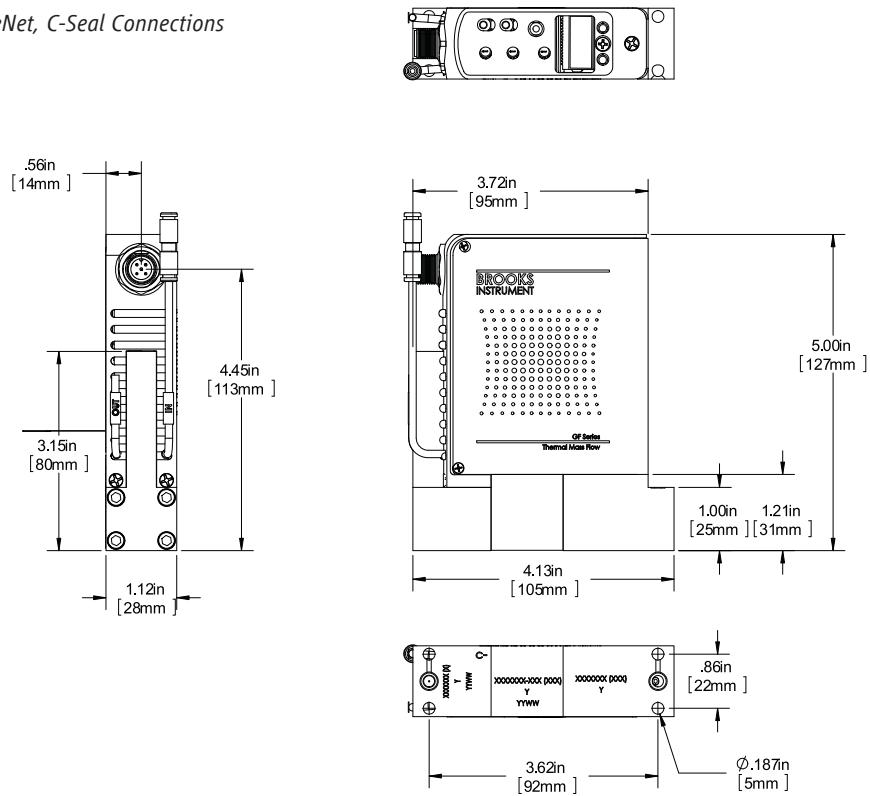

Figure 1-3 Dimensions - GF100/GF120/GF125 Series

# Section 1 Introduction

Model GF135, DeviceNet, C-Seal Connections



Model GF135, DeviceNet, VCR Connections

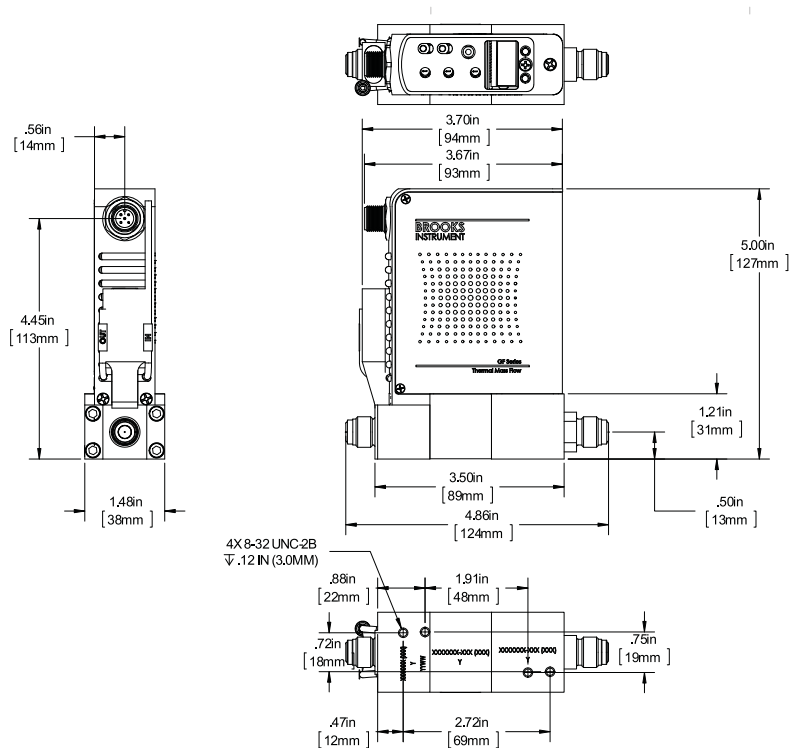

Model GF135, RS485, C-Seal Connections

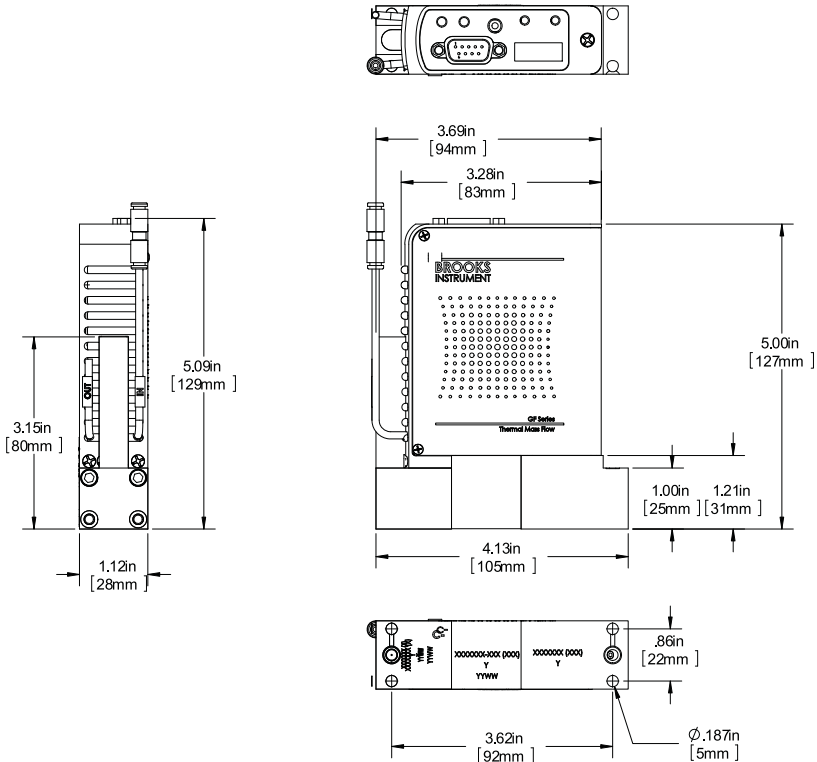

Model GF135, RS485, VCR Connections

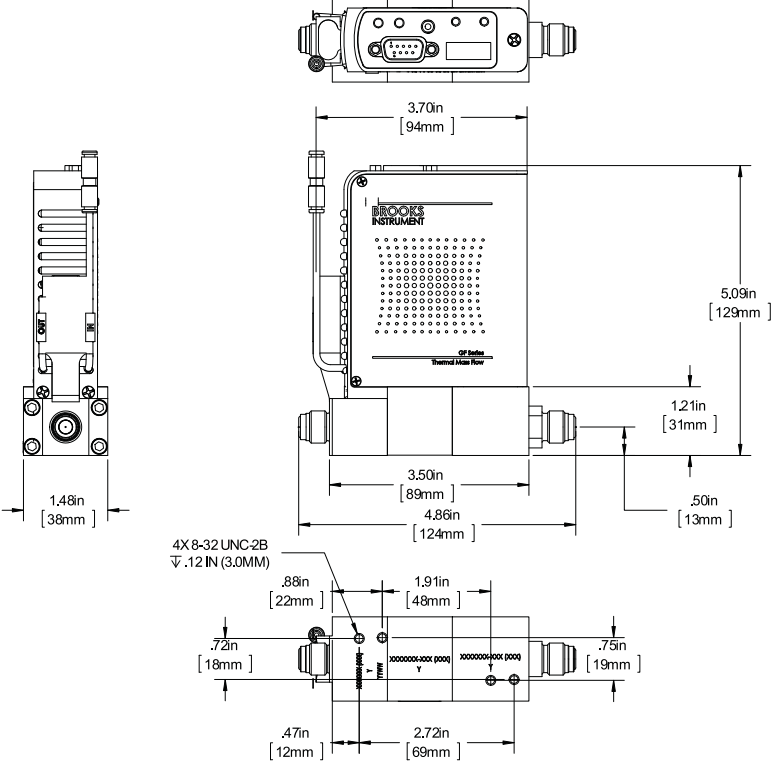
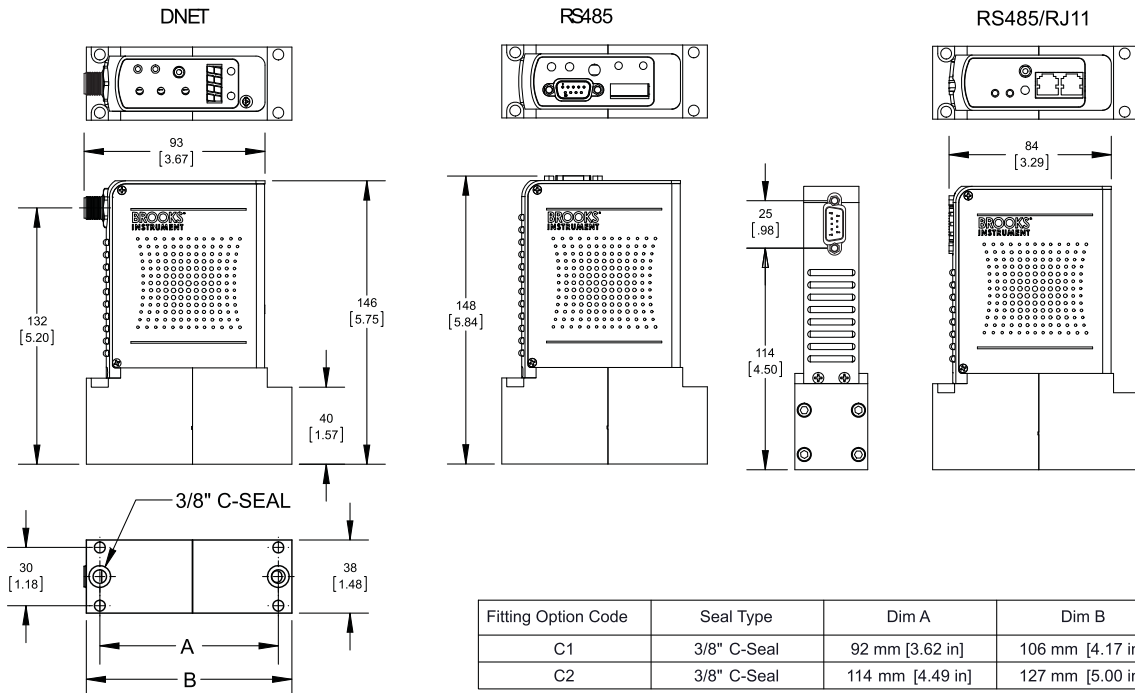

Figure 1-5 Dimensions - GF135 Series, RS485

# Section 1 Introduction

## C-Seal Configurations



## VCR Configurations

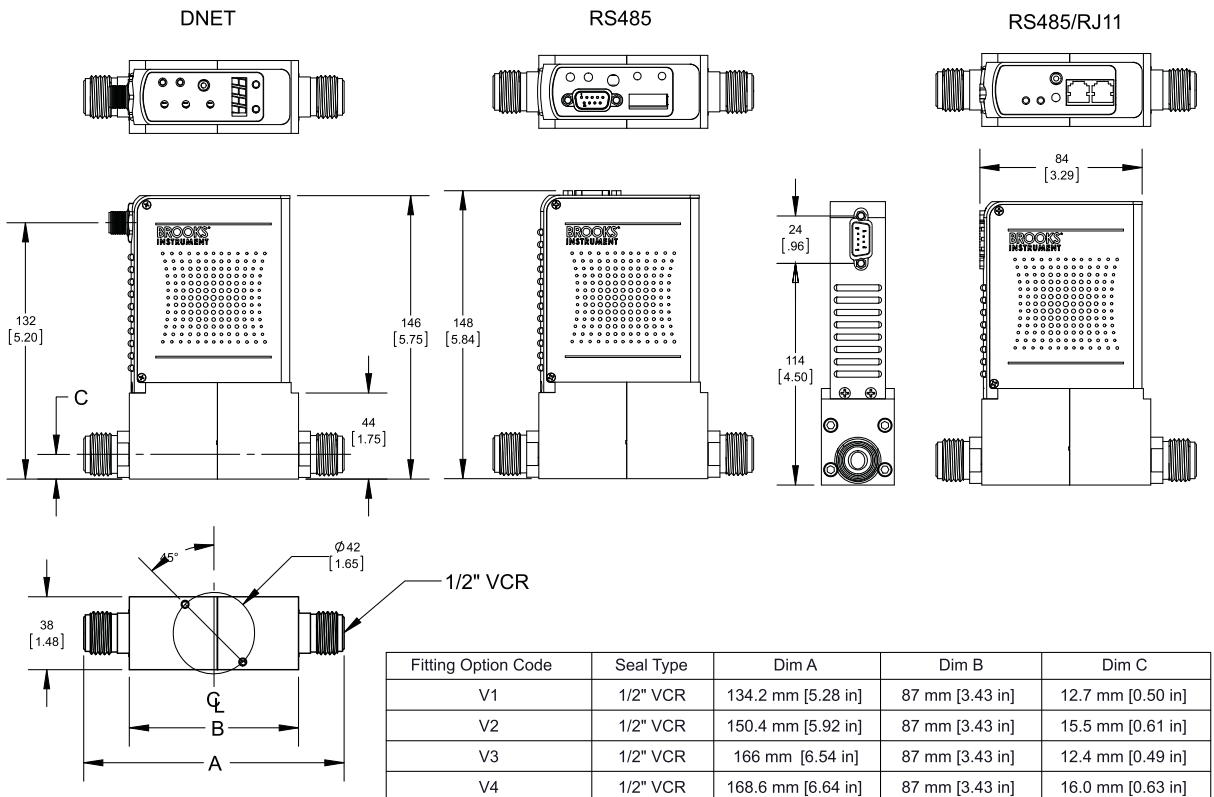

EtherCAT, Downport Configurations

GF100/120/125

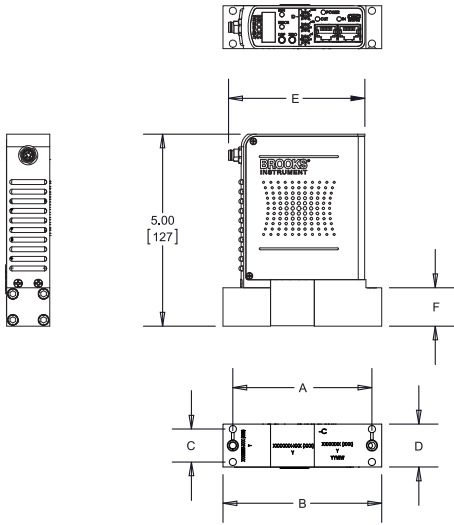

GF101/121/126

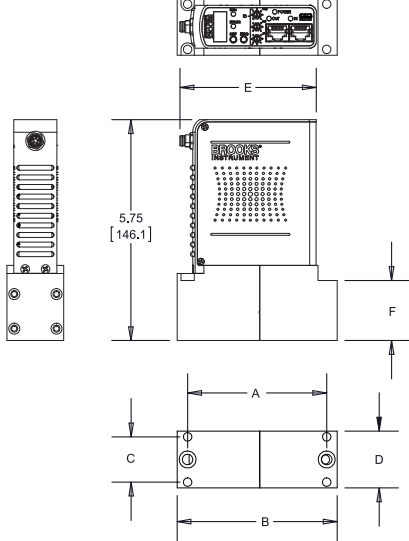

Fitting Option Code	Model	Seal Type	Dim A	Dim b	Dim C	Dim D	Dim E	Dim F
CX	GF100/120/ 125	C-Seal	3.62 [92]	4.13 [105]	0.86 [21.7]	1.12 [28.4]	3.55 [90.2]	1.00 [25.4]
WX	GF100/120/ 125	W-Seal	3.62 [92]	4.13 [105]	0.86 [21.7]	1.12 [28.4]	3.55 [90.2]	1.00 [25.4]
C1	GF101/121/ 126	C-Seal	3.62 [92]	4.17 [106]	1.18 [30]	1.48 [37.6]	3.55 [90.2]	1.57 [39.8]
C2	GF101/121/ 126	C-Seal	4.49 [114]	5.00 [127]	1.18 [30]	1.48 [37.6]	3.55 [90.2]	1.57 [39.8]

NOTE: [ ] ALTERNATE DIMENSION UNITS ARE FOR REFERENCE ONLY.

EtherCAT, VCR Configurations

GF100/120/125

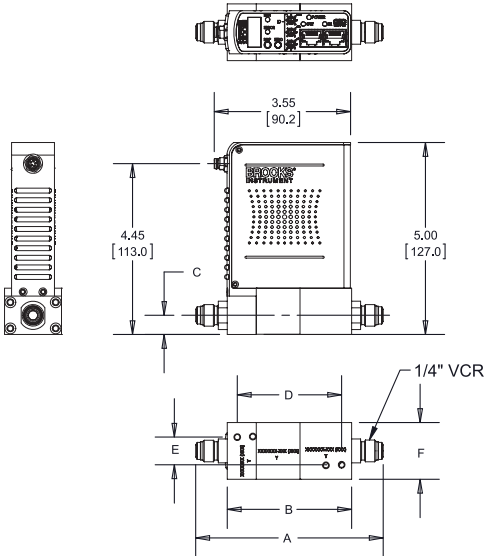

GF101/121/126

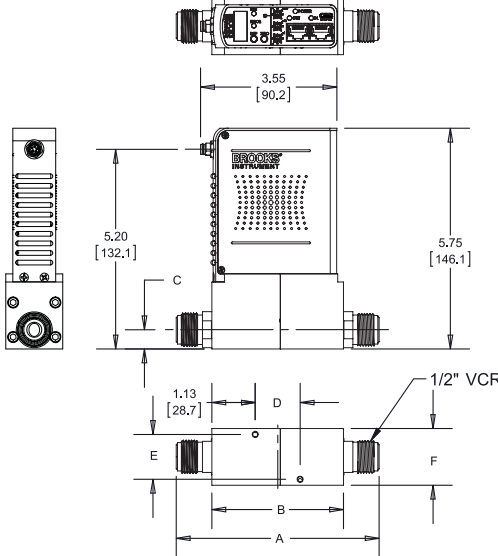

Fitting Option Code	Model	VCR	Dim A	Dim B	Dim C	Dim D	Dim E	Dim F
VS	GF100/120/ 125	1/4"	4.88 [124]	3.24 [82]	0.50 [12.7]	2.72 [69]	0.72 [18]	1.12 [28.4]
VX	GF100/120/ 125	1/4"	4.88 [124]	3.24 [82]	0.50 [12.7]	2.72 [69]	0.72 [18]	1.48 [37.6]
V1	GF101/121/ 126	1/2"	5.28 [134.2]	3.43 [87]	0.50 [12.7]	1.17 [29.7]	1.17 [29.7]	1.48 [37.6]

NOTE: [ ] ALTERNATE DIMENSION UNITS ARE FOR REFERENCE ONLY.

Figure 1-7 Dimensions - GF100/GF120/GF125, GF101/GF121/GF126 Series with EtherCAT Communications

### General

This section provides installation instructions for the Brooks GF100 Series Thermal Mass Flow Devices. The installation process consists of purging the gas supply line prior to installation, unpacking and inspecting the device, connecting the device to the gas supply line and testing for leaks.

### Receipt of Equipment

When the equipment is received, the outside packing case should be checked for damage incurred during shipment. If the packing case is damaged, the local carrier should be notified at once regarding his liability. A report should be submitted to the nearest Brooks Instrument location listed on the Global Service Network page on our website:

[BrooksInstrument.com/GlobalSupportCenters](http://BrooksInstrument.com/GlobalSupportCenters)

This device has been assembled, calibrated, and double-vacuum bagged in a Class 100 clean room. In your semi-clean area, remove the outer bag only. Pass the device into your clean area. Remove the second clean room compatible bag only when the device is ready to be tested and/or installed in your clean system.

### Recommended Storage Practice

If intermediate or long-term storage of the device is required, it is recommended that it be stored in accordance with the following conditions:

- Within the original shipping container.
- Ambient temperature 21°C (70°F) nominal, 32°C (90°F) maximum, 7°C (45°F) minimum.
- Relative humidity 45% nominal, 60% maximum, 25% minimum.

### Return Shipment

Prior to returning any instrument to the factory for any reason, visit our website for instructions on how to obtain a Return Materials Authorization Number (RMA #) and complete a Decontamination Statement to accompany it: [BrooksInstrument.com/Service](http://BrooksInstrument.com/Service). All instruments returned to Brooks also require a Material Safety Data Sheet (MSDS) for the fluid(s) used in the instrument. Failure to provide this information will delay processing of the instrument.

Instrument must have been purged in accordance with the following:

#### **WARNING**

**Before returning the device, purge thoroughly with a dry inert gas such as Nitrogen before disconnecting process connections. Failure to correctly purge the instrument could result in fire, explosion or death. Corrosion or contamination may occur upon exposure to air.**



## Section 2 Installation

### Transit Precautions

To safeguard against damage during transit, transport the device to the installation site in the same container used for transportation from the factory, if circumstances permit.

### Removal from Storage

Upon removal of the device from storage, a visual inspection should be conducted to verify its "as-received" condition. If the device has been subject to storage conditions in excess of those recommended (refer to "2-3 Recommended Storage Practice" on p. 2-1), it should be subjected to a pneumatic pressure test in accordance with applicable vessel codes. To maintain a devices ultraclean integrity, this service should be performed by the factory or one of the certified service centers.

### Gas Connections

Prior to installation, ensure that all piping is clean and free from obstructions. Install piping in such a manner that permits easy access to the device if removal becomes necessary.

### In-Line Filter

It is recommended that an in-line filter be installed upstream from the device to prevent the possibility of any foreign material entering the flow sensor or control valve. The filtering element should be replaced periodically or ultrasonically cleaned.

### Mechanical Installation

#### CAUTION

**When installing the Mass Flow Controller or Meter, care should be taken that no foreign materials enter the inlet or outlet of the instrument. Do not remove the protective end caps until the time of installation.**

The recommended installation procedure guidelines are as follows:

- The device should be located in a clean, dry atmosphere relatively free from shock and vibration.
- Leave sufficient room for access to the user interface, display and MAC ID and baud rate switches (if equipped) at the top of the device.
- Install the device in such a manner that permits easy purge and removal if the device requires servicing.

#### CAUTION

**When used with a reactive (sometimes toxic) gas, contamination or corrosion may occur as a result of plumbing leaks or improper purging. Plumbing should be checked carefully for leaks and the instrument purged with clean, dry N<sub>2</sub> before use.**

The GF100 Series is equipped with PTI technology, which reduces the effect of pressure fluctuations on gas flow. In PTI technology, a signal from an integrated pressure transducer is combined with the standard thermal sensor output. The combined signals allow precise and stable flow, even when the line pressure is fluctuating.

The GF100 Series also utilizes MultiFlo® technology that allows the user to configure standard configurations ("SHs") or "blanks" for a variety of pure gases and mixtures. As a result, MultiFlo® technology enables the user to reduce unique inventory requirements.

### Flow Controller Installation Arrangement

Typical gas supply arrangements are shown in Figures 2-1 and 2-2. GF100's are often arranged inside a gas panel. Configure standard configurations ("SHs") or "blanks" for a variety of pure gases and mixtures. As a result, MultiFlo technology enables the user to reduce unique inventory requirements.

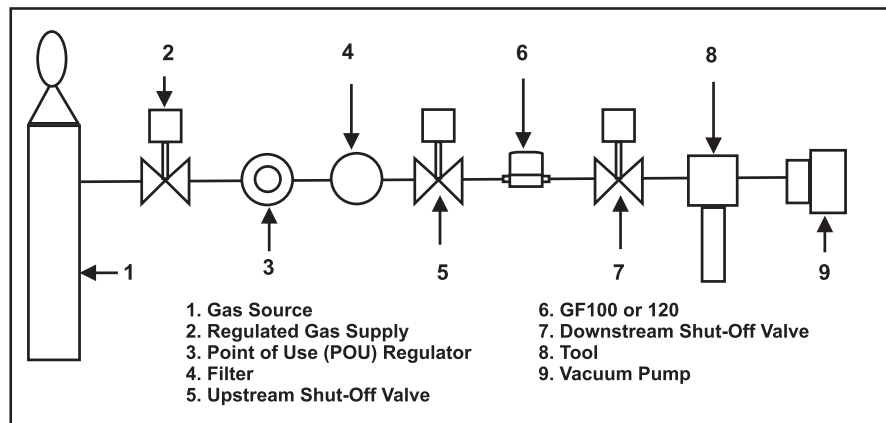

Figure 2-1 Typical Gas Supply Arrangement with non-PTI MFC

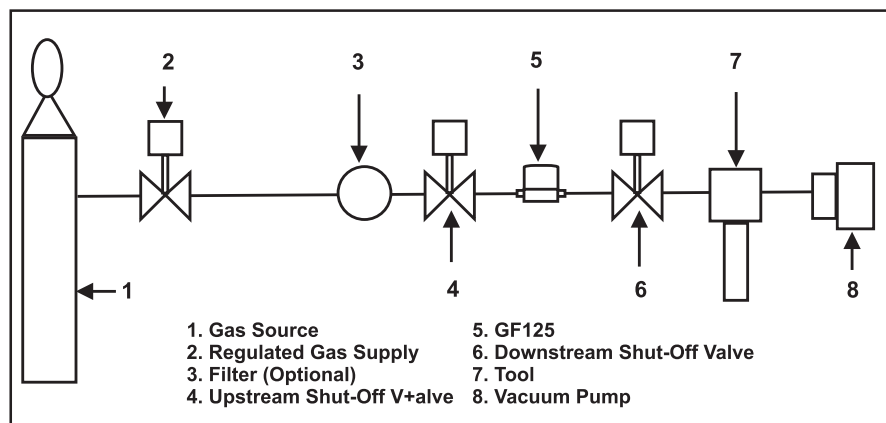

Figure 2-2 Typical Gas Supply Arrangement with PTI MFC

## Section 2 Installation

### Purge the Gas Supply Line Before GF100 Series Installation

#### CAUTION

For additional safety, it is recommended to close the two valves between the charged gas line and the GF100 Series to be installed. See Figures 2-1 and 2-2 for more details.

#### NOTICE

It is recommended to archive service and calibration documentation for the GF100 Series in order to determine the contamination state of each gas line and to assist service personnel.

#### CAUTION

**DO NOT** remove the shipping caps covering the inlet/outlet for VCR fittings, or **DO NOT** remove the blue tape on the bottom of the device for downported fittings before the GF100 Series is actually being installed. Failure to comply will introduce contaminants into the GF100 Series.

Before operating the GF100 Series, the gas supply line must be completely purged with nitrogen or argon to ensure the line is free from toxic or flammable gases, contaminants, moisture, and oxygen. The purge gas must be free of moisture and oxygen to less than 100 ppb. Purge the gas lines as follows or in accordance to prescribed company and safety procedures.

1. Shut off the process gas supply valve(s) upstream of the GF100 Series. If such a valve is not available, shut the valve on the gas panel. Tag the valve at this point to prevent accidental re-exposure of the process gas to the gas line.
2. Cycle purge the gas line with dry nitrogen or argon to fully flush out the process gas. Cycle purging consists of evacuating to a low pressure adequate to induce out-gassing and then purging to remove adhered moisture and oxygen. If a toxic or reactive gas is present and a clogged GF100 Series is suspected, then proceed with caution. Pump down and purge the GF100 Series from both downstream and upstream lines. If check valves are present in the gas line, both pumping down and purging are required. Pumping down without purging is inadequate. If a good vacuum source is not available, the GF100 Series can be decontaminated by purge only.
3. Repeat the purge cycle several times within 2-4 hours to complete the cleaning. For toxic and corrosive gasses, it is recommended to use 100-120 cycles.

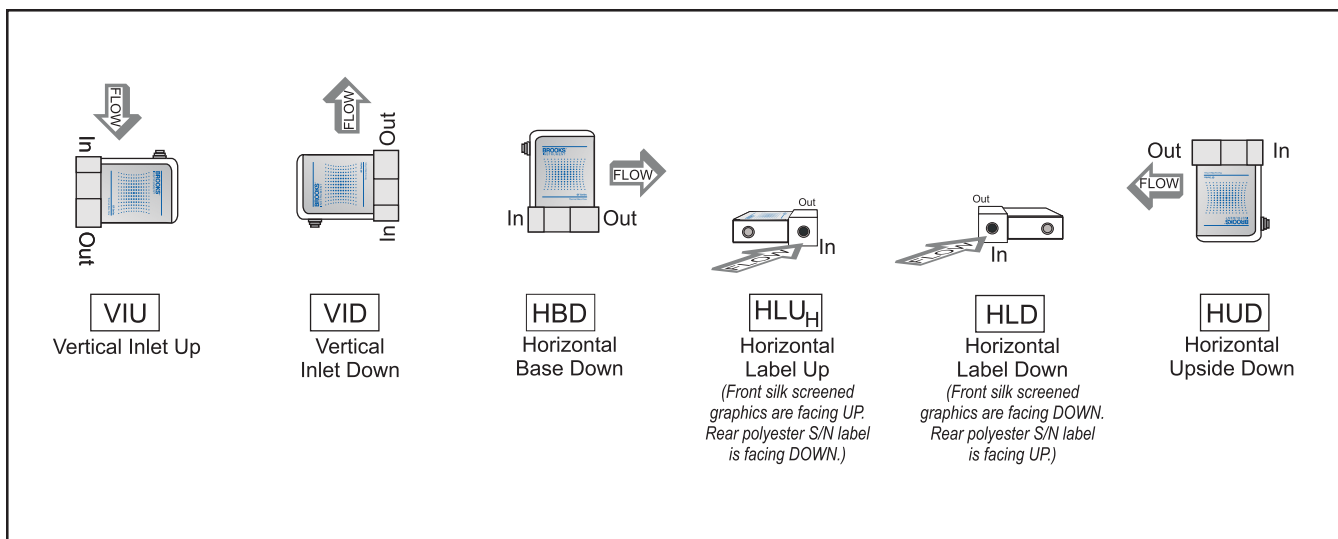

Figure 2-3 GF100 Series Mounting Attitude Positions

### Position and Mount the GF100 Series

Position the GF100 Series so that the gas flow is pointed in the direction of the flow arrow on the GF100 Series rear S/N label. The various mounting positions are described in Figure 2-3

The standard orientation for the GF100 Series is Horizontal Base Down (HBD). The GF125 & GF135 employ a proprietary algorithm that utilizes the internal pressure sensor to compensate for potential orientation effects when the MFC is used with certain higher density gases. Non HBD mounting orientations can be selected by using the MultiFlo software.

In the case of the GF100/120 Series, which does not have an internal pressure sensor, it is recommended that the MFC is re-zeroed with process gas following the recommended Brooks procedure (see zeroing bulletin FSB-001-0015 for further information).

If your GF100 Series is configured with downported fittings, follow Steps 1 through 4 below. If your GF100 Series has VCR fittings, proceed to Step 5.

1. Refer to Figure 2-4. If downported fittings (1) are used, the GF100 Series is mounted to K1 Series substrate blocks (2) with four screws (3). Metal C-seals or W-seals (4) (as provided by integrator) are inserted between the GF100 Series and substrate blocks before the screws are installed. These metal seals must be replaced after each installation.
2. Select the mounting screws noted in Table 2-1 below for downported devices. M4 screws are used on 1.125" devices, K1S. M5 screws are used on 1.5" devices, K1R2 and K1H.
3. Refer to Figure 2-4. Insert the two mounting seals (4) over the gas flow path of the K1 block. Carefully align the GF100 Series mounting holes onto the K1 substrate blocks. Using your fingers, install the screws through the GF100 Series fitting and hand tighten.

## Section 2 Installation

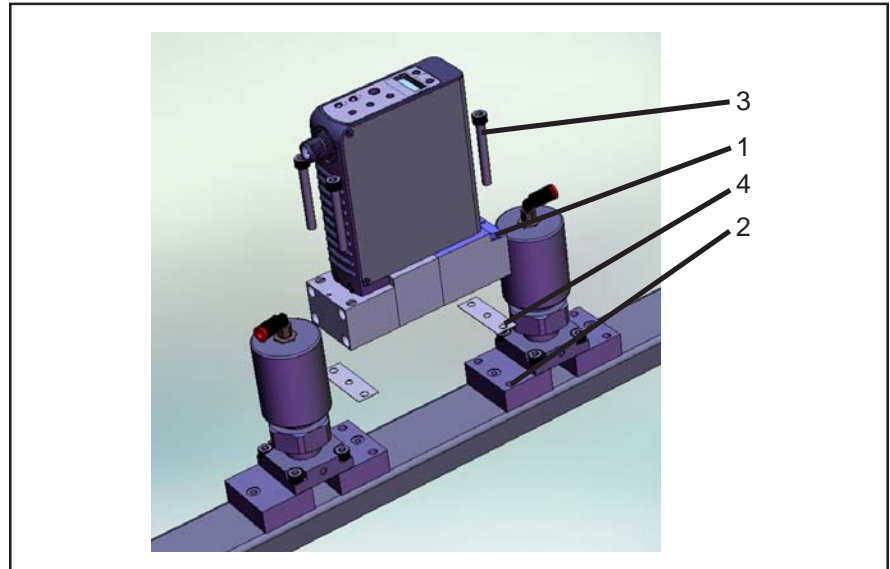

Figure 2-4 GF100 Series Mounted to K1 Series Substrate Blocks

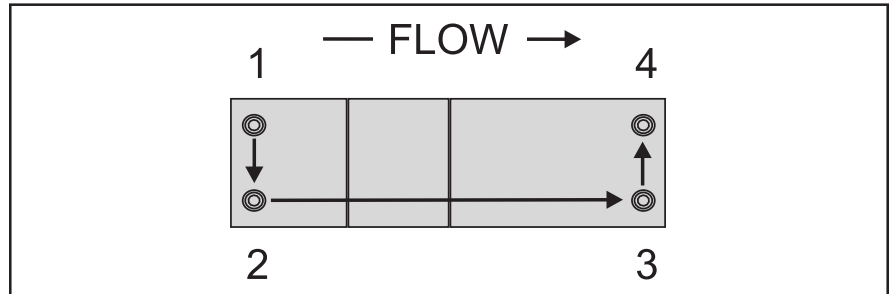

Figure 2-5 Mounting Screws Torque Pattern\*

Table 2-1 K1 Series Fasteners\*

Connection	Fastener Size		
	K1S	K1R2	K1H
GF 100 Series to Substrate	M4 x 34mm or M4 x 35mm	M5 x 30mm	M5 x 37mm

Table 2-2 K1 Substrate Torque Data\*

Connection	Torque Pattern	Torque (Inch-Pounds)		
		K1S	K1R2	K1H
GF125 to Substrate	Use a square pattern as shown in Figure 2-5. Start at 25 inch-pounds and increase in increments of 10 inch-pounds until proper value is obtained.	45	45	45

- Using a torque wrench and a metric hex key, tighten the screws to the torque value as described in Table 2-2 and Torque Pattern Figure 2-5.
- If your GF100 Series is configured with ¼" VCR fittings, secure the GF100 Series block to the gas panel with two, 8-32-UNC-2B" screws. Then connect the inlet/ outlet fittings to the gas supply line using two wrenches. Tighten the fittings to manufacturer recommendations.

\*Torquing methodology is the responsibility of the tool manufacturer

### Perform a Leak Test

#### **⚠ WARNING**

**Before operating the flow controller, ensure all gas connections have been properly tightened and, where applicable, all electrical connections have been properly terminated.**

It is critical to leak test the gas supply lines and GF100 Series connections before turning on the process gas supply after any new installation. Check for leaks using a helium leak detector or any other appropriate leak test method. Follow leak test specifications as defined by integrator.

### Zeroing Setup Process

The following steps are required before the GF100 Series is zeroed.

1. Make sure that the GF100 Series has been installed inside the equipment (panel) for at least four hours and powered up at least one hour prior to zeroing. This insures that the GF100 Series is in its "use attitude" and is operating at normal temperature. If the GF100 Series is subjected to a vacuum purge for more than one minute, turn off the GF100 Series (ie., provide a zero setpoint) for a time period of twice the vacuum purge time.
2. Refer to Figure 2-1. Open the upstream shut-off valve (5) and close the downstream shut-off valve (7). This eliminates a pressure drop across the GF100 Series and subsequent leakage from the PID control valve inside the GF100 Series.
3. Provide a 100% setpoint to the GF100 Series for no longer than 60 seconds. This equalizes the pressure across the PID control valve.
4. Refer to Figure 2-1. Close the upstream shut-off valve (5) to prevent any pressure effects from the regulator (3).
5. Close the GF100 Series and wait two minutes.
6. Read the output signal of the GF100 Series. This output signal is the initial flow in percent of full scale. The output signal should be 0.0 ( $\pm$  0.1%). If the output signal is too high, re-zero the GF100 Series as described in Section 2-15.

### Zeroing the GF100 Series

Many high density gases exhibit slight changes in zero output as a function of inlet pressure. Gases such as tungsten hexafluoride and many fluorocarbons are especially sensitive to this problem. Since inlet pressure is a potential source for zero errors, the pressure transducer on each GF100 Series should be correctly set to zero after installation. The zeroing process is performed from the backlight LCD display on top of the GF100 Series.

OEM tools using a microprocessor or computer for operating the GF100 Series should sequence the GF100 Series off between processes. To accomplish this, simply provide a zero set point. The GF100 Series will shut off automatically.

### **⚠ NOTICE**

**Make sure you perform the zeroing set-up process outlined in Section 2-14 before zeroing the GF100 Series.**

Shut-off valves, whether upstream or downstream from the GF100 Series, should be programmed to turn on before the GF100 Series is turned on and turned off after the GF100 Series is turned off.

### **Zeroing the GF100 Series Pressure Transducer from the LCD Display Panel**

1. Place the GF100 Series under a strong vacuum with the GF100 Series set to 100% set point. Make sure that upstream valve is closed and the downstream valve is open. Allow time for the upstream pressure to bleed off.
2. Looking at the top of the GF100 Series, press the "Display" button, starting at the MACID, four times to "PSI" or five times to "kPa" or until the LCD displays the labels "PSI" or "kPa". The GF100 Series will display pressure in units of PSIA or kPa. Press and hold down the Zero button a minimum of 5 seconds or until the display reads 0.000, with the last two digits flickering at different values. The pressure transducer zeroing procedure can be done while the display is either in PSIA or kPa output. Refer to Figure 2-6.

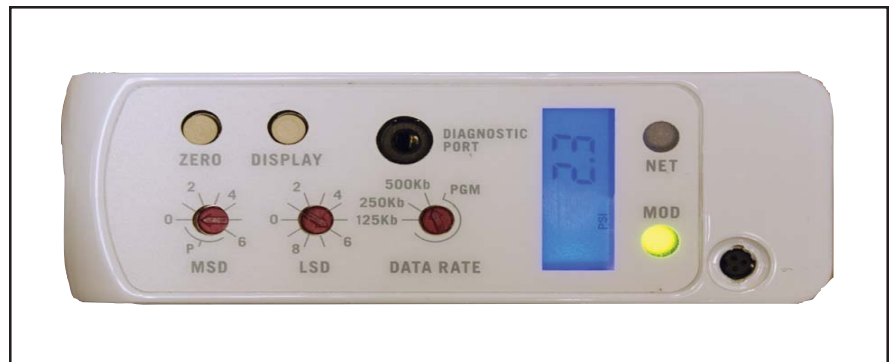

Figure 2-6 Display with PSI Reading

After completion of the pressure transducer zeroing, the LCD display will read 0.0 with the last two digits flickering as shown in Figure 2-7.

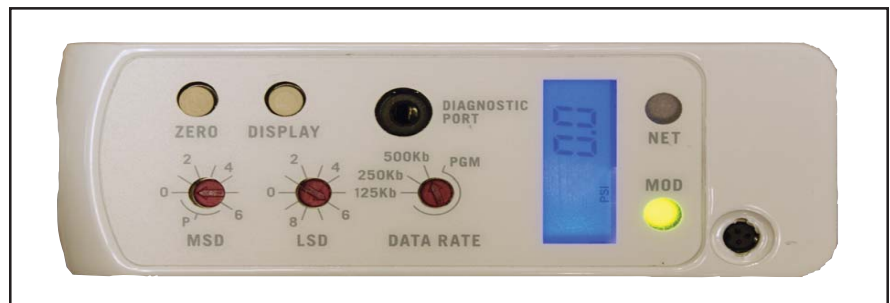

Figure 2-7 Display Reading Zero PSI

## Zeroing GF100 Series Flow from LCD Display Panel

1. Place the GF100 Series under normal inlet operating pressure. Close the down stream valve to prevent any flow.
2. Looking at the top of the GF100 Series, press the "Display" button until the LCD display label is "%FS" as shown in Figure 2-8. Three button depressions from the MACID label display.

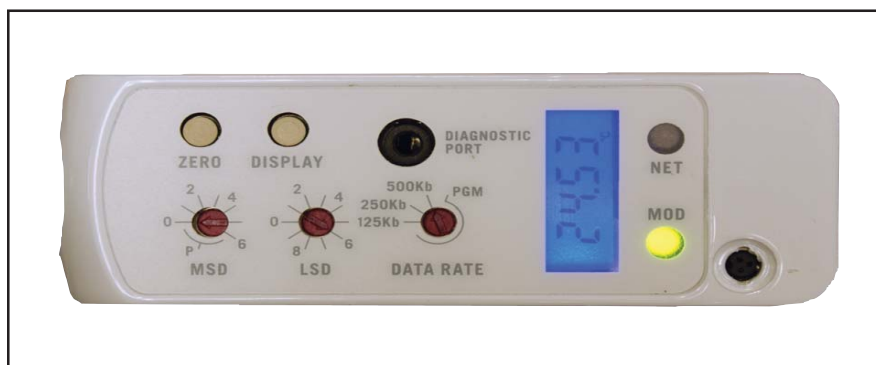

Figure 2-8 Display Set to %FS

3. Press and hold down the Zero button for a minimum of 5 seconds or until the "%FS" display reads 0.0 as shown in Figure 2-9. The %FS label will flash during this procedure.

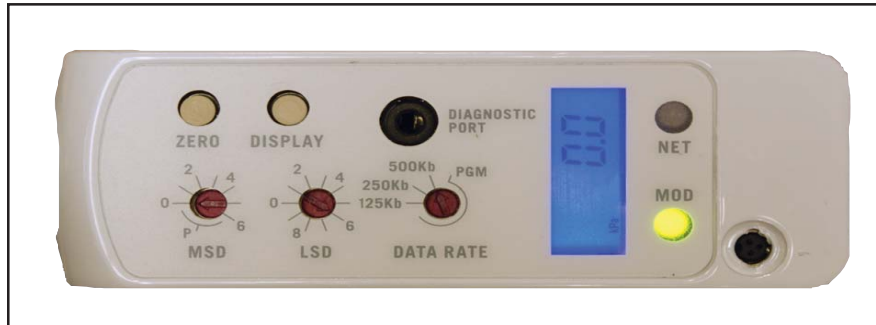

Figure 2-9 % Flow Display Set to Zero

## Performance Checks

This section describes how to zero and sequence the GF100 Series devices for proper operation.

### **⚠ NOTICE**

**If the GF100 Series has been in the purge mode for a long period of time, wait until the GF100 Series has cooled down before zeroing. The cool down period should be ~30 minutes for purges up to five minutes and at least 60 minutes after purging overnight.**

- The GF100 Series must be warmed up for at least 30 minutes.
- The active gas page must be correct.
- The GF100 Series pressure transducer must be correctly zeroed.
- The GF100 Series flow must be correctly zeroed.



## Section 2 Installation

### Introduction to the MultiFlo™ Configurator

The MultiFlo Configurator application is used to configure the gas and range of the GF Series devices. The following section describes the MultiFlo Configurator and its uses.

### Using the MultiFlo Configurator

The MultiFlo Configurator application allows communication to GF Series devices through personal computer with serial COM Port and a Windows 10, Windows 7 or Windows XP operating system. It's primary function is to configure gas and flow ranges within six defined standard configurations. Flow ranges are configured to the Nitrogen equivalent.

Using the MultiFlo Configurator software, configure the gas and flow rate according to Table 2-3.

*Table 2-3 Gas and Flow Ranges - MultiFlo Configurable - N2 Equivalent*

Standard MG-MR Bin Configurations	Flow range Code	Gas Flow Range (N2 Equivalent)
SH40	010C	3-10 sccm
SH41	030C	11-30 sccm
SH42	092C	31-92 sccm
SH43	280C	93-280 sccm
SH44	860C	281-860 sccm
SH45	2.6L	861-2600 sccm
SH46	7.2L	2601-7200 sccm
SH47	015L	7201-15000 sccm
SH48	030L	15001-30000 sccm
SH49	040L	30001-40000 sccm
SH50	055L	40001-55000 sccm

The MultiFlo Configurator interfaces to the GF Series device through RS485 or DeviceNet communications. There are various ways to connect the device regardless of device configuration. Devices may be connected through the diagnostic port using cables in one of the two Basic MultiFlo Configurator Kits or DeviceNet devices can alternatively be connected using a National Instruments or SST DeviceNet scanner card.

#### **778Z010ZZZ Basic MultiFlo Configurator Kit**

A331710003 Cable Assembly 2.5mm

214F027AAA USB-RS485 Converter with DB-9 female

#### **778Z011ZZZ Basic MultiFlo Configurator Kit**

w/Power Supply and Adapter Cables

A331710003 Cable Assembly 2.5mm

214F027AAA USB-RS485 Converter with DB-9 female

A332295001 Power Supply MFC

A332297002 Cable, Power, 9-Pin

A332297001 Cable, Power, DeviceNet

Connect the MultiFlo Cable Adapter 2.5mm jack to the Diagnostic Port on the top of the device. See Figure 2-12.

Connect the RS485 end of the converter to the 9-Pin RS485 end of the MultiFlo Cable Adapter.

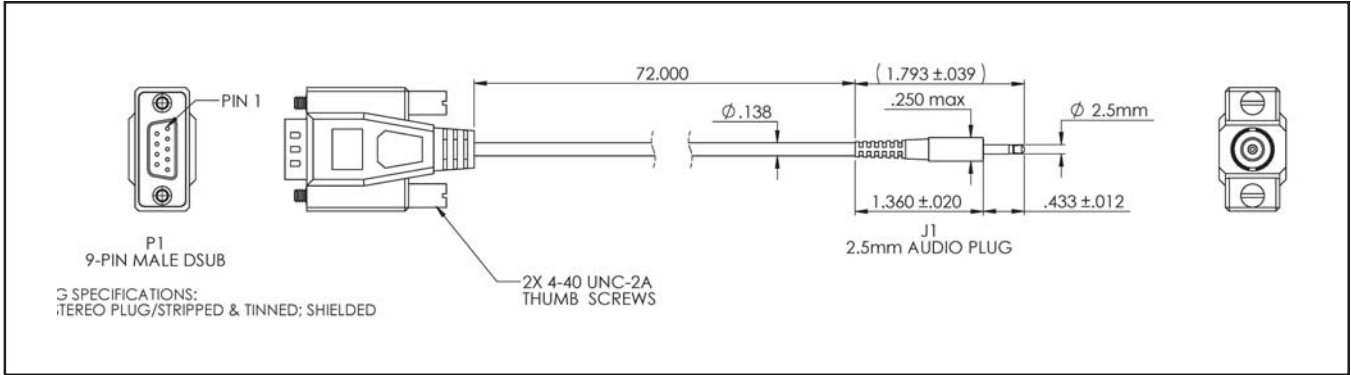

Figure 2-10 MultiFlo Cable Adapter



Figure 2-11 USB-RS485 Converter (214F027AAA)

Connect the USB end of the converter to a laptop or PC. For GF1xx devices with EtherCAT communication, the diagnostic port must be used to interface with the MultiFlo Configurator.

- Ensure the M8 power connector is attached and the device is powered on
- Only after the device is powered on, attach a micro-USB cable to the diagnostic port of the device and the USB end to a laptop or PC
- Once use of the diagnostic port is complete, remove the micro-USB cable before removing power from the device. See Figure 2-12 below

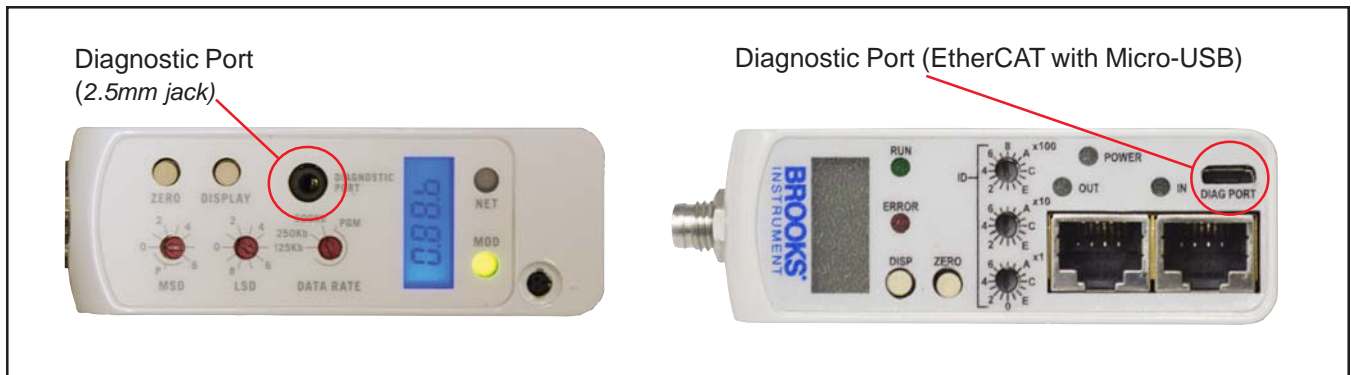

Figure 2-12 Diagnostic Port Locations

## Section 2 Installation

The latest MultiFlo Configurator Software and Databases and MultiFlo Configurator Quick Start Guide are available on the Brooks Instrument website at: [www.BrooksInstrument.com/MultiFlo](http://www.BrooksInstrument.com/MultiFlo). Please reference the MultiFlo Configurator Quick Start Guide for installation and operation details. Download the MultiFlo Configurator software into your computer from the Brooks Instrument website [www.BrooksInstrument.com/MultiFlo](http://www.BrooksInstrument.com/MultiFlo). Install the MultiFlo Configurator as described in the MultiFlo Configurator Quick Start Guide and use the guide as a reference for operation details.

### **⚠ CAUTION**

**DO NOT** make any connections to unlabeled connector pins. Any failure to comply could damage the GF100 Series and/or the mating electrical device. Before connecting the cable, make sure that all pin connections of the mating cable have the same pin out connections. When installing and removing cables to and from your computer, make sure the power is turned off on your computer. This will prevent damage to your computer and associated equipment.

### Electrical Connections

### DeviceNet Connections

DeviceNet is a 5 wire local network connection that employs a command response communication protocol for communicating between a master and slave. Obtain a DeviceNet communication cable (Micro M-12) and fasten it to the 5-pin connector as shown in Figure 2-13.

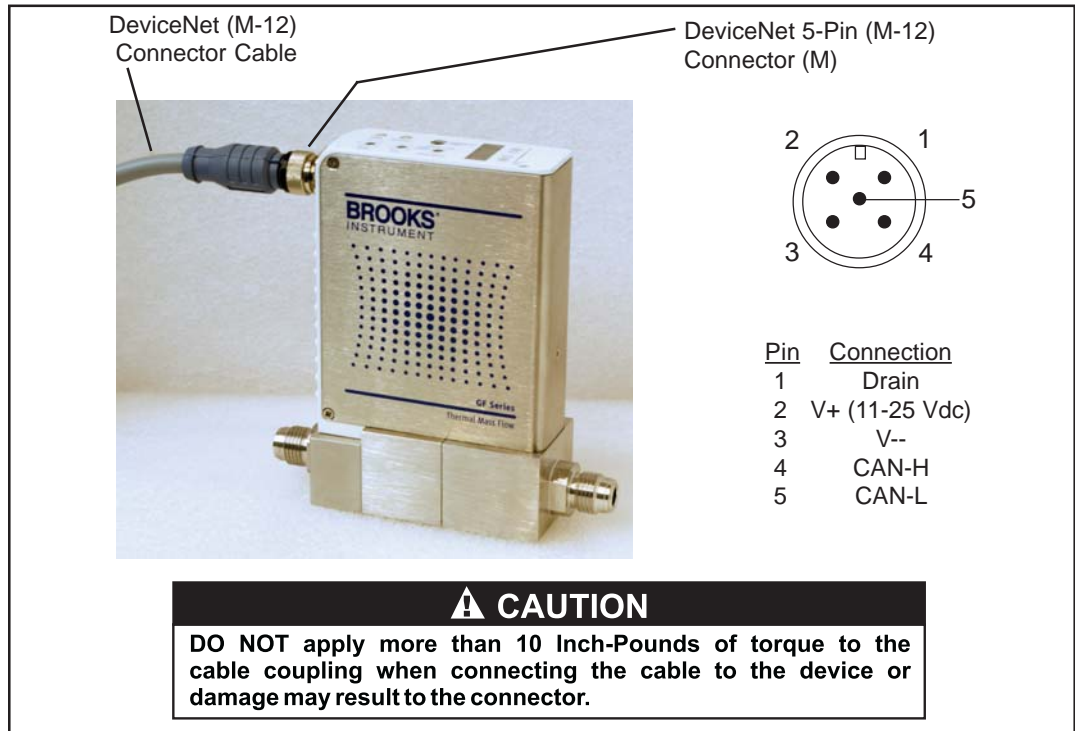

Analog/RS485 Connections

The GF100 Series devices are available with Analog 9-Pin D-Connectors shown in Figure 2-14.

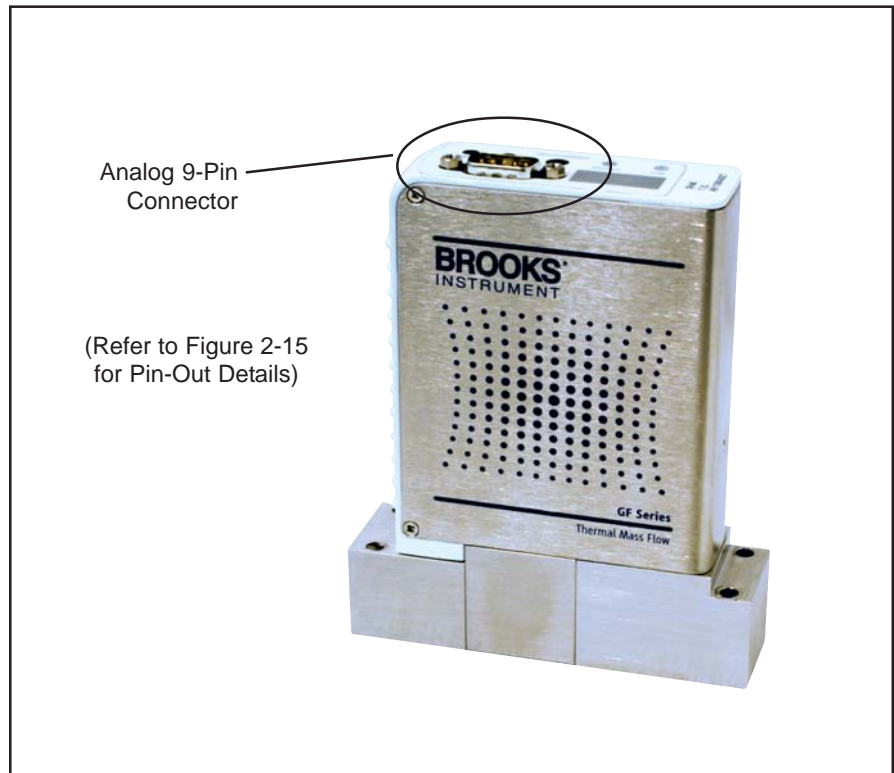

Figure 2-14 GF100 Series with 9-Pin Analog Connector

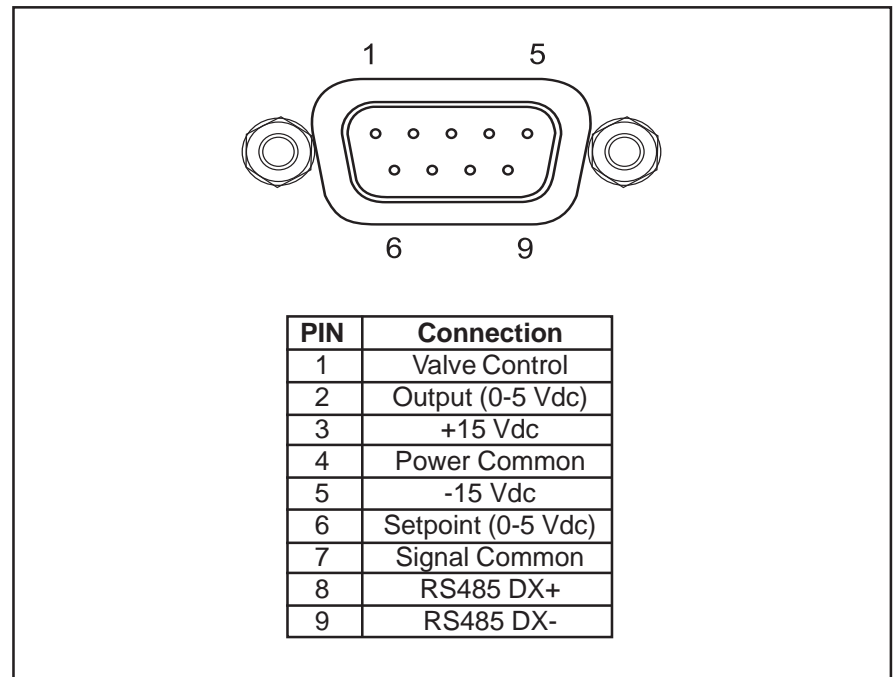

Figure 2-15 Analog 9-Pin Connector (M)

## Section 2 Installation

### EtherCAT Connections

Power needs to be supplied via the standard male M8 5-pin connector. The M8 connector is located on the upper inlet side of the device. Refer to Figures 2-16 and 2-17 below.



Figure 2-16 GF100 with EtherCAT Communications, M8 Power Connector Location.

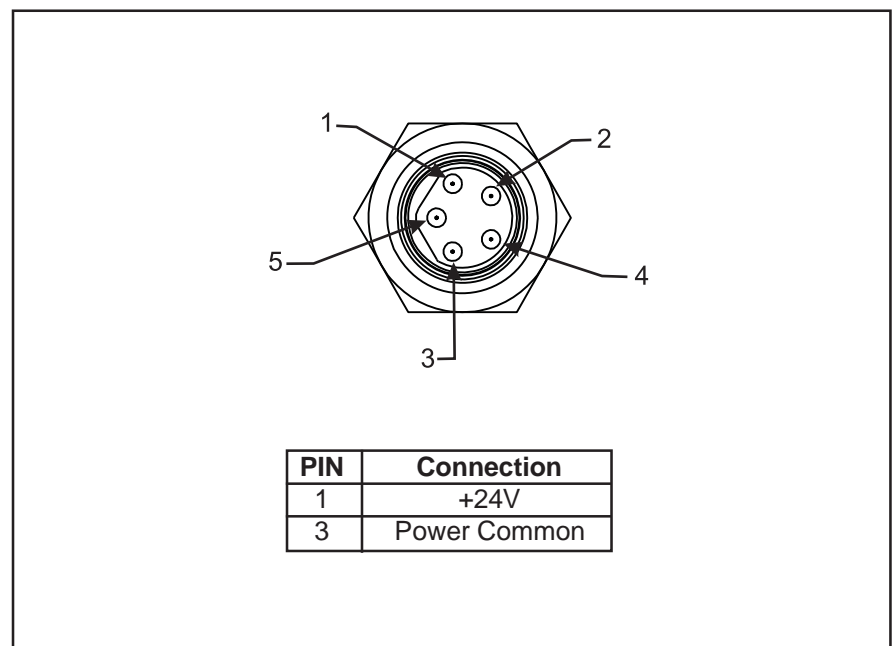
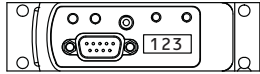

Figure 2-17 M8 Power Connector Drawing

Base I/O Options

**PDC Ordering Code G1**

Description: Industry standard Analog / RS485 interface



Pin No.	Signals
1	Valve Control
2	Output (0-5 Vdc)
3	+15 Vdc +24 Vdc
4	Pwr Com NC
5	-15 Vdc Pwr Com
6	Setpoint (0-5 Vdc)
7	Signal Common
8	RS-485 (DX+)
9	RS-485 (DX-)

**PDC Ordering Code GX**

Description: OEM specific Analog / RS485 interface. Display and top plate re-oriented 180°

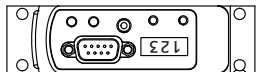

Pin No.	Signals
1	Valve Control
2	Output (0-5 Vdc)
3	+15 Vdc +24 Vdc
4	Pwr Com NC
5	-15 Vdc Pwr Com
6	Setpoint (0-5 Vdc)
7	Signal Common
8	RS-485 (DX+)
9	RS-485 (DX-)

**PDC Ordering Code DX**

Description: Industry standard ODVA compliant DeviceNet interface

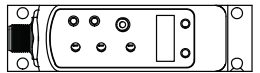

M12 Pin No.	Signals
1	Drain
2	V+ (11-25 Vdc)
3	V-
4	CAN-H
5	CAN-L

**PDC Ordering Code TX**

Description: Industry standard Analog only interface

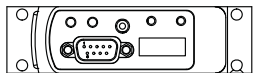

Pin No.	Signals
1	Valve Control
2	Output (0-5 Vdc)
3	+15 Vdc +24 Vdc
4	Pwr Com NC
5	-15 Vdc Pwr Com
6	Setpoint (0-5 Vdc)
7	Signal Common
8	No Connection
9	No Connection

**PDC Ordering Code SX**

Description: Industry standard Analog 9-Pin Sub D connector and dual RJ11 RS485 ports

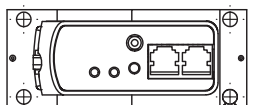

D-Sub Pin No.	Signals
1	Valve Control
2	Output (0-5 Vdc)
3	+15 Vdc +24 Vdc
4	Pwr Com NC
5	-15 Vdc Pwr Com
6	Setpoint (0-5 Vdc)
7	Signal Common
8	Signal Common
9	Valve Test Point

RJ11 J2 Pin No.	Signals
3	RS-485 (DX-)
4	RS-485 (DX+)

**PDC Ordering Code BB**

Description: Industry standard ODVA compliant DeviceNet interface, Plus a separate Analog 0-5 Vdc Connector

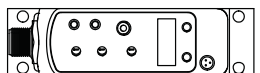

M12 Pin No.	Signals
1	Drain
2	V+ (11-25 Vdc)
3	V-
4	CAN-H
5	CAN-L

HIROSE Pin No.	Signals
1	Flow Out
2	AGND
3	GPIO CAPO
4	GHD Earth

All Base I/O options include:  
Diagnostic port communication RS485 via 2.5mm jack

I/O Options Using Base Model and Adapter Cable

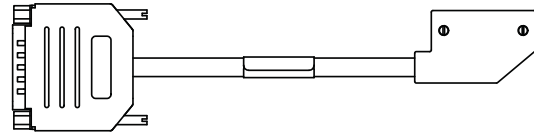

A range of low profile adapter cables have been developed to support replacing older generation MFC's with different pinout configurations. The base MFC would be either a G1, TX or SX configuration, depending on the product being replaced.

**PDC Ordering Code UX**

Description: SX base I/O with 7003550 adapter for compatibility with Unit UDU15

Pin No	Signals
9	VALVE OFF
6	OUTPUT ( 0-5 VDC )
4	+15 VDC +24 VDC
7	PWR COM NC
11	-15 VDC PWR COM
15	SETPOINT ( 0-5 VDC )
1,13,14	SIGNAL COMMON
2	ZERO ALARM
12	VALVE TEST POINT
8	CASE GROUND
3,5,10	NO CONNECTION

**PDC Ordering Code: T1**

Description: TX base I/O with 7003551 adapter for compatibility with IFlow DB15 & TN 15 pin

Pin No	Signals
15	VALVE OFF
2	OUTPUT ( 0-5 Vdc )
5	+15 VDC +24 VDC
1	PWR COM NC
6	-15 VDC PWR COM
8	SETPOINT ( 0-5 VDC )
9	COMMON
10	COMMON
14	CASE GROUND
3,4,7	NO CONNECTION
11,12,13	NO CONNECTION

**PDC Ordering Code: FX / JX**

Description: SX base I/O with 7003069 (FX)/7001814 (JX) adapter for compatibility with Unit UDF9/UDJ9

Pin No	Signals
1	VALVE CONTROL*
2	OUTPUT ( 0-5 VDC )
3	+15 VDC +24 VDC
4	PWR COM NC
5	-15 VDC PWR COM
6	SETPOINT ( 0-5 VDC )
7	SIGNAL COMMON
8	SIGNAL COMMON
9	VALVE TEST POINT

**PDC Ordering Code: EX**

Description: GX base I/O with 7003083 adapter for compatibility with Unit "E", "IN", "L", "R"

Pin No	Signals
J	VALVE OFF
3	OUTPUT ( 0-5 VDC )
4	+15 VDC +24 VDC
2	PWR COM NC
F	-15 VDC PWR COM
A	SETPOINT ( 0-5 VDC )
B,C,10	SIGNAL COMMON
1	CASE GROUND
5, 6, 8, 9	NOT CONNECTED
I, D, E, H	NOT CONNECTED
7, G	KEY WAY

RJ11 J2 Pin No	RJ11 J3 Pin No	Signals
3	3	RS-485 (DX-)
4	4	RS-485 (DX+)

**PDC Ordering Code: KX**

Description: G1 base I/O with 7003298 adapter for compatibility with Unit UDK15

Pin No	Signals
3	VALVE CONTROL
2	OUTPUT ( 0-5 VDC )
7	+15 VDC +24 VDC
5	PWR COM NC
6	-15 VDC PWR COM
8	SETPOINT ( 0-5 VDC )
11,12	SIGNAL COMMON
15	CASE GROUND
1, 4, 9, 10, 13, 14	NO CONNECTION

**PDC Ordering Code: BX**

Description: G1 base I/O with 7003590 adapter for compatibility with Brooks 15-Pin D

Pin No	Signals
12	VALVE OVERRIDE
2	OUTPUT ( 0-5 VDC )
5	+15 VDC +24 VDC
9	PWR COM NC
6	-15 VDC PWR COM
8	SETPOINT ( 0-5 VDC )
1,10	SIGNAL COMMON
3,4,7,11	NO CONNECTION
13,14,15	NO CONNECTION

Other adapter options are available for the GF Series. Please contact Brooks Customer Service for more information.

Figure 2-18 GF100 Series Electrical Interface Options

## Section 2 Installation

### GF135 Inlet Valve Installation

When installing the GF135 –

1. Connect the MFC tubing labeled "IN" to a CDA or N2 supply of  $90 \pm 3$  psi.
2. Next, the MFC tubing labeled "OUT" should be connected to the customer upstream pneumatic isolation valve.

Note – The air passes through a failsafe normally open valve inside the GF135 and is connected back to the inlet isolation valve. For safe operation and in line with S2 compliance, the GF135 cannot override and open the inlet isolation valve.

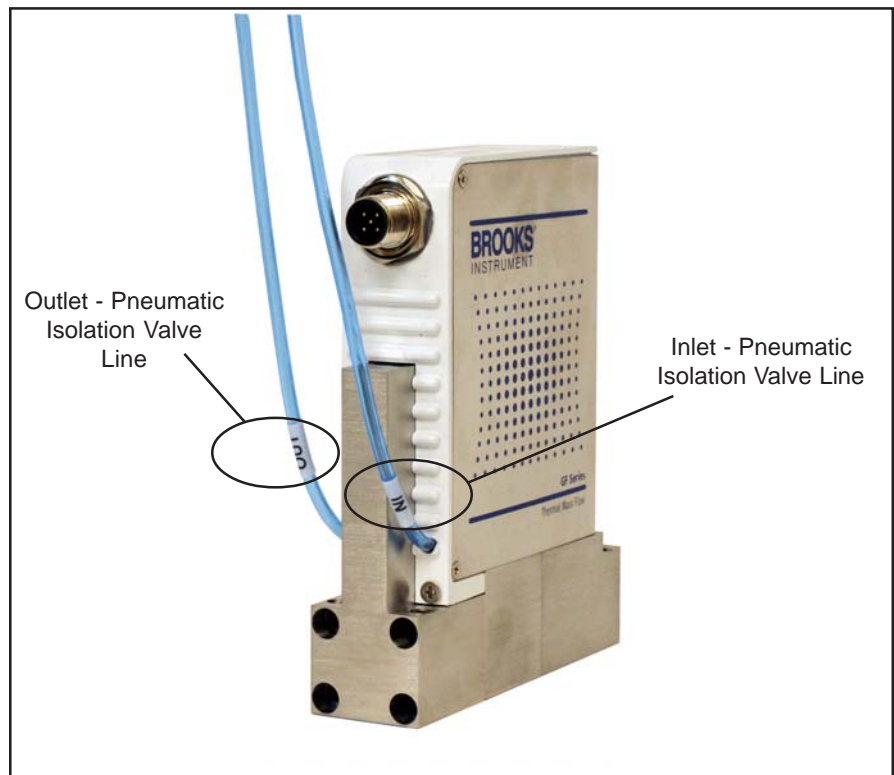

Figure 2-19 GF135 Series Showing Inlet/Outlet Pneumatic Isolation Valve Lines



### GF135 Commissioning

Download the GF135 commissioning software, part number 805-C-026, from the Brooks Instrument website. The software will need to be downloaded onto a computer with a Windows® based operating system.

Necessary equipment:

- Computer that runs a Windows operating system
- Power (either DeviceNet or RS485) to the device or M8 EtherCAT power
- Need gas supply for pneumatic valve (90 ±3 psi)
- BB 485 to 232 converter or approved USB to 485 converter
- 9-pin to diagnostic cable

In order to ensure best results, commission the GF135 at operating temperature and pressure on tool.

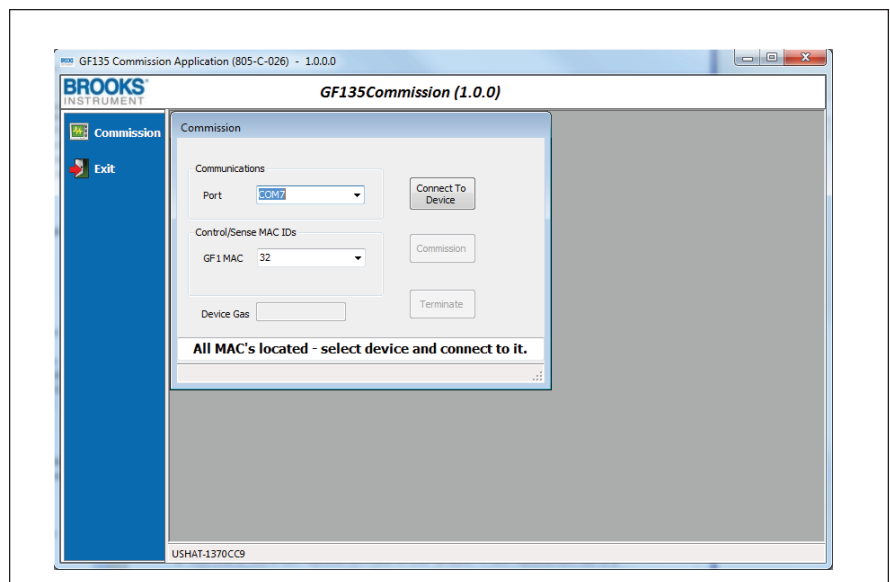

1. Start up the GF135 Commission Application and select a port. This will bring up all of the devices on this port.



## Section 2 Installation

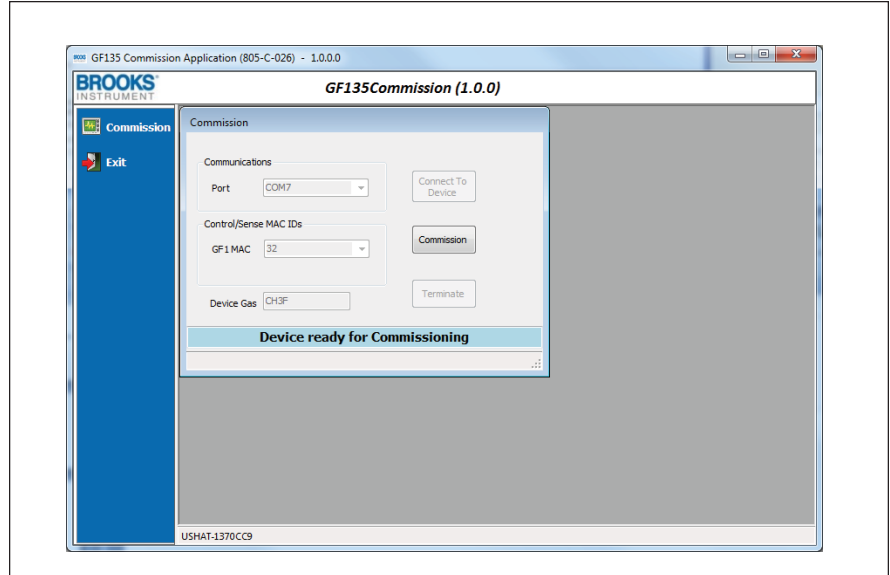

2. Select the single device that you want to perform the commissioning and click on "Connect to Device". The Commissioning button becomes enabled.

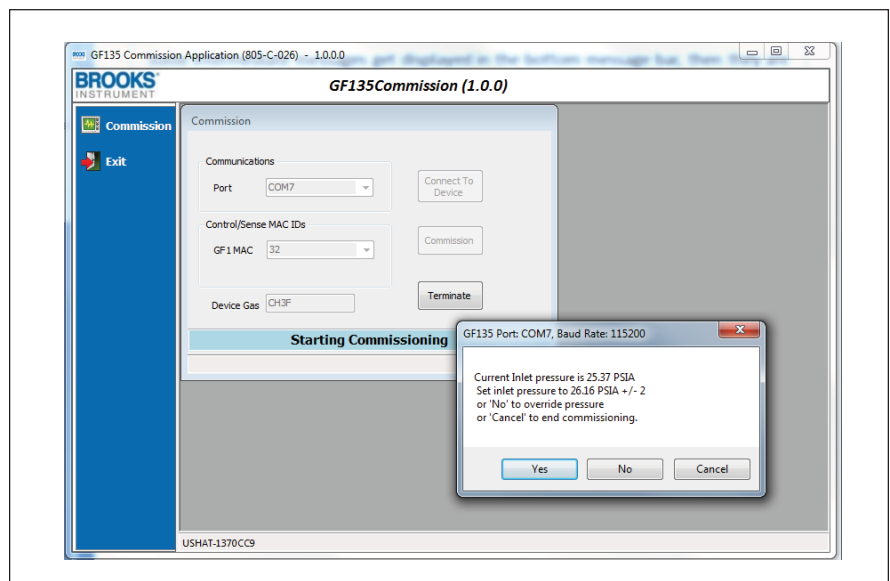

3. Click on the "Commission" button to begin the process. Some intermediate messages will appear on the bottom message bar. You will then be presented the option to override the current inlet gas pressure. Selecting "Yes" will keep the current inlet pressure. Selecting "No" will allow the user to override the pressure. Selecting "Cancel" will end the commissioning process.

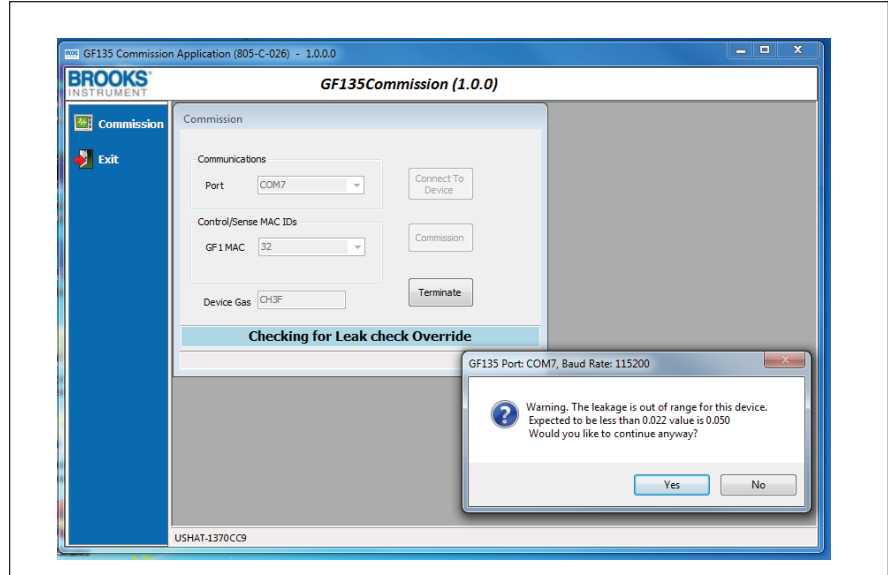

4. The user will be presented the option to override a few of the parameters being tested prior to actual commissioning. Selecting "Yes" will continue the process. By selecting "No" the commissioning process will end.

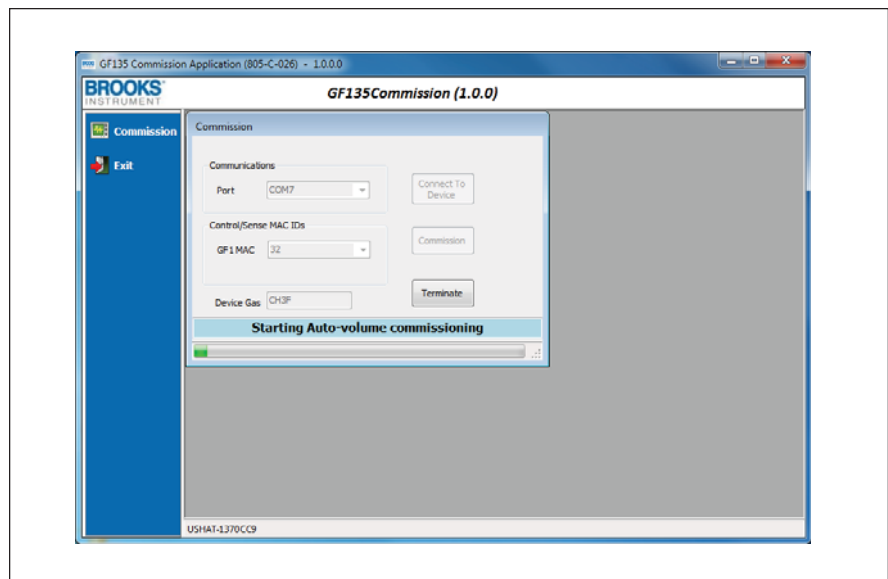

5. After numerous checks are performed, the auto-volume will start. This will take approximately 5 minutes to complete. The K1 setpoints will then begin. This process will run for approximately 40-90 minutes.

## Section 2 Installation

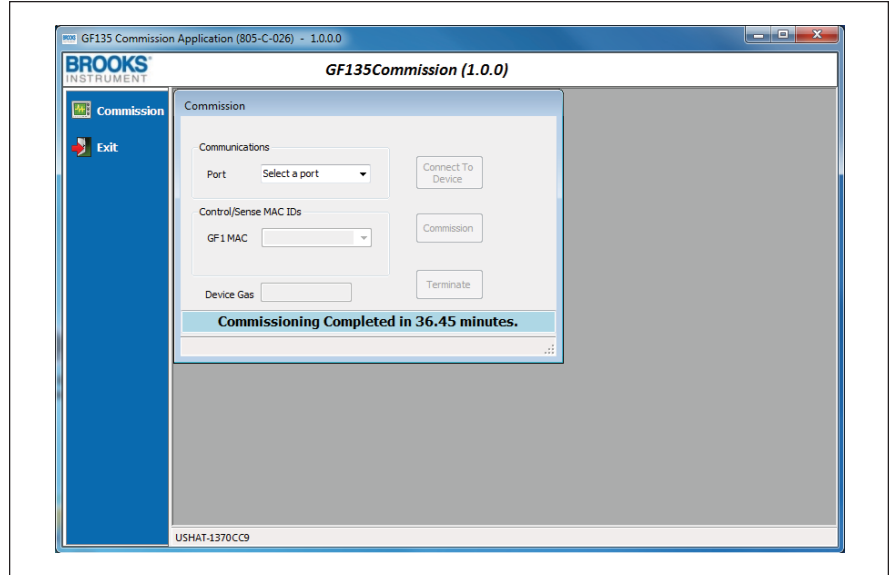

6. Once the auto-volume and the K1 set points are complete, the program will go back to the initial screen. In addition, the overall run time will be displayed. From here, another device (or the same one again) may be selected for commissioning.

### General

After the device has been properly installed in the process, it is ready for operation. When initiating flow, slowly open any upstream shutoff valve to avoid a flow surge. A bypass is helpful in bringing the flow on smoothly. Avoid starting a pump to supply the device without the use of a valve upstream of the device.

#### **⚠ CAUTION**

**Any sudden change in system pressure may cause mechanical damage to elastomer materials. Damage can occur when there is a rapid expansion of fluid that has permeated elastomer materials. The user must take the necessary precautions to avoid such conditions.**

#### **⚠ WARNING**

**Before operating the flow controller, ensure all gas connections have been properly tightened and, where applicable, all electrical connections have been properly terminated.**

### Theory of Operation for Flow Measurement

The thermal mass flow measurement system consists of two components: the restrictor or bypass and the flow sensor. Figure 3-1 is diagram of the flow stream through the device, with an enlarged view of the flow sensor. Gas flow entering the device is separated into two paths; one straight through the restrictor and the other through the flow sensor. This is represented in Figure 3-1, where the total flow  $A+B$  enters the device and is separated into streams  $A$  and  $B$ . The streams are joined again at the far side of the restrictor.

The separation of the flow streams is caused by the restrictor. During flow conditions, there will be a pressure differential across the restrictor that forces gas to flow in the sensor.

The pressure difference caused by the restrictor varies linearly with total flow rate. The sensor has the same linear pressure difference versus flow relationship. The ratio of sensor flow to the flow through the restrictor remains constant over the range of the device ( $A/B = \text{constant}$ ). The full scale flow rate of the device is established by selecting a restrictor with the correct pressure differential for the desired flow.

The flow sensor is a very narrow, thin-walled Hastelloy tube. Onto this tube are built upstream and downstream temperature sensing and heating elements. During no-flow conditions, the amount of heat reaching each temperature sensor is equal, so temperatures  $T_1$  and  $T_2$  (Figure 3-1) are equal. Gas flowing through the tube carries heat away from the upstream temperature sensor and toward the downstream sensor. The temperature difference,  $T_2 - T_1$ , is directly proportional to the gas mass flow. GF100 Series operating principles are described in Figure 3-1.

## Section 3 Operation

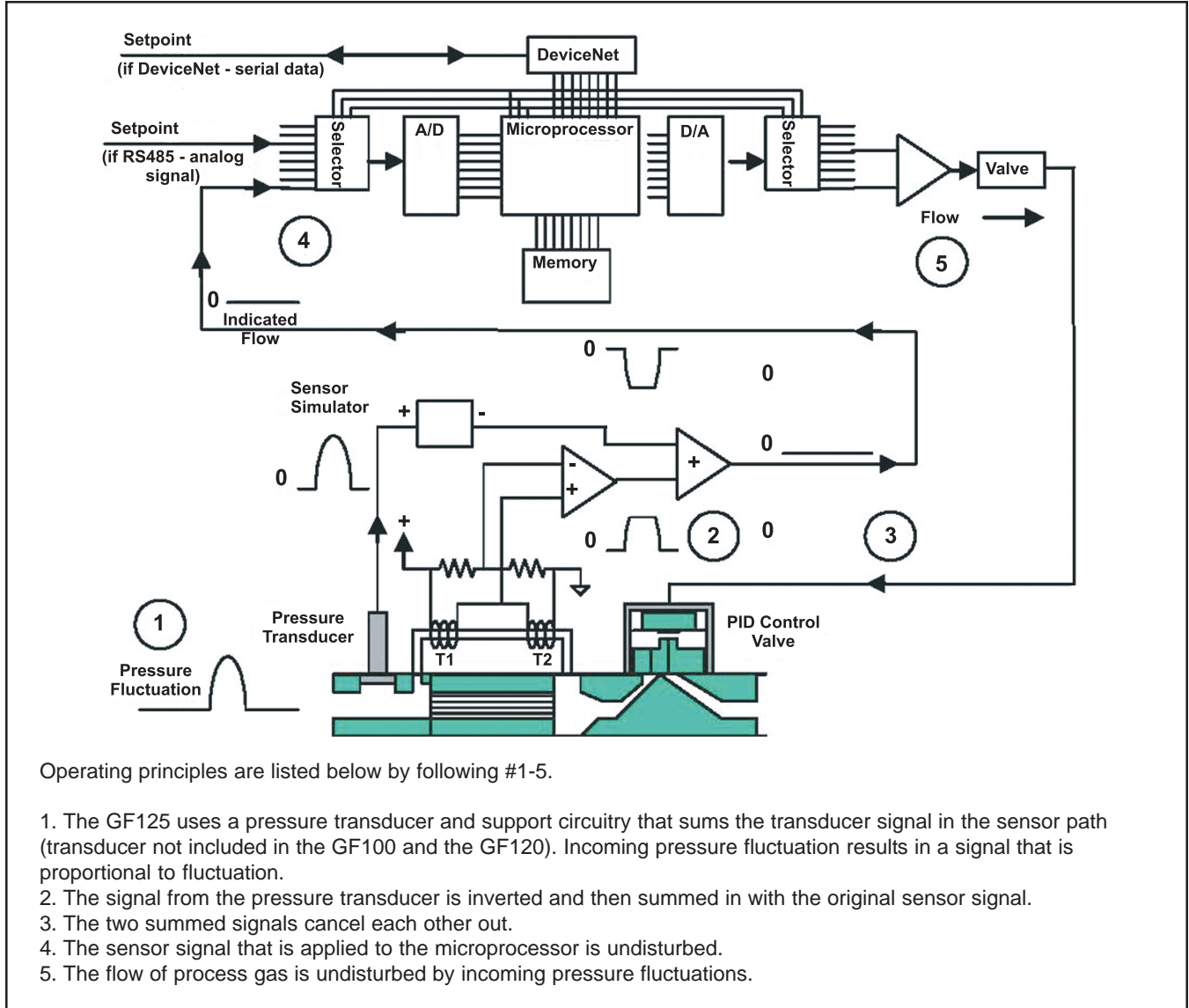

Figure 3-1 GF100 Series Operating Principles

## Section 4 Maintenance & Troubleshooting

### Overview

No routine maintenance is required on the Brooks GF100 Series devices. If an in-line filter is used, the filtering elements should be periodically replaced or cleaned. Any precision unit such as a flow controller requires occasional servicing, especially if it has been operating for an extended period of time. If reactive gases are being used, it is recommended that you send the device to a Brooks Service Center for cleaning and recalibration. Please follow the instructions for removal, product packaging and product return instructions found in Section 2- Installation—Return Shipment. All active process instrumentation and equipment is subject to aging and wear from their environment. This includes temperature, mechanical stress, component tolerance shift, contaminant buildup, oxidation, and other influences. The effects are gradual, but over time the changes can affect the accuracy of even the best equipment. Therefore, it is recommended to re-zero the device at 6 month intervals. Refer to Section 2-18 Performance Checks for re-zeroing instructions.

### Maintenance

	<b>⚠ WARNING</b>
<b>METER/CONTROLLER SEAL COMPATIBILITY</b>	
<p>Products in this manual may contain metal or elastomeric seals, gaskets, O-rings or valve seats. It is the "user's" responsibility to select materials that are compatible with their process and process conditions. Using materials that are not compatible with the process or process conditions could result in the Meter or Controller leaking process fluid outside the pressure boundary of the device, resulting in personnel injury or death.</p>	
<p>It is recommended that the user check the Meter or Controller on a regular schedule to ensure that it is leak free as both metal and elastomeric seals, gaskets, O-rings and valve seats may change with age, exposure to process fluid, temperature, and /or pressure.</p>	

## Section 4 Maintenance & Troubleshooting

### **WARNING**

If it becomes necessary to remove the controller from the system after exposure to toxic, pyrophoric, flammable or corrosive gas, purge the controller thoroughly with a dry inert gas such as Nitrogen before disconnection the gas connections. Failure to correctly purge the controller could result in fire, explosion or death. Corrosion or contamination of the mass flow controller, upon exposure to air, may also occur.

### **WARNING**

If it becomes necessary to remove the instrument from the system, power to the device must be disconnected.

### **CAUTION**

It is important that this MFC/MFM only be serviced by properly trained and qualified personnel.

### **CAUTION**

This instrument contains electronic components that are susceptible to damage by static electricity. Proper handling procedures must be observed during the removal, installation or other handling of internal circuit boards or devices.

### Troubleshooting

This section includes a Troubleshooting Checklist and a GF100 Series Troubleshooting Guide that identifies symptoms, possible causes, and corrective actions.

#### **⚠ NOTICE**

**OEM tool problems are often caused by something other than the GF100 Series. Therefore, Brooks recommends that you review both the Troubleshooting Checklist and the GF100 Series Troubleshooting Guide before removing the GF100 Series from your system. It is also suggested to contact your Brooks Service representative before removing the GF100 Series from your system.**

### Troubleshooting Checklist

1. Check environmental factors that could affect changes to GF100 Series performance. The most common environmental factors are listed in Table 4-1.

*Table 4-1 Environmental Factors*

<b>GF100 Series Performance</b>	<b>Possible Causes</b>
Inaccurate flow.	Temperature shift (steady state or transient). Inlet pressure shift (steady state or transient). Power supply problem. Electrical interference Dirty gas chamber Changes in gas.
Control problems. Can not reach setpoint. Oscillation.	Differential pressure not within operating range Inlet pressure not stable
Zeroing problems, Indicated zero is not stable.	Temperature shift (steady state or transient). Inlet pressure shift (steady state or transient). Power supply problem. Electrical interference

2. Check supply voltage and check for a consistent ground.
3. Insure OEM tool setpoint matches the setpoint at the GF100 Series. Observe for consistency.
4. Verify isolations valves are open and the gas supply is turned on. Then verify operating pressures are within operating ranges.
5. Check GF100 Series voltage response by moving the setpoint back and forth. Observe for voltage changes.



## Section 4 Maintenance & Troubleshooting

### GF100 Series Troubleshooting Guide

Table 4-2 GF100 Series Troubleshooting Guide

Symptoms & Possible Causes	Corrective Action
<b>1. No gas flow.</b>	
Is the gas supply turned on?	Check shut-off valve and pressure readout. Open the gas supply.
Is the regulator turned on at the correct operating pressure?	Turn off the regulator and reset it to the recommended pressure as described in the Data Sheet.
Are any upstream or downstream shut-off valves closed, either by the system or because of failure?	Verify that the valves are open and operating properly.
Is the MOD LED light on the GF100 Series lit solid green?	Observe the LED display panel on top of to verify. If the LED light is not lit, cycle power the to reboot.
Is the commanded setpoint from tool/system at 0.00 Vdc?	Use the tool software to verify.
Has the been commanded off by an active "valve closed" input?	Use the tool software to verify.
<b>2. Flow out of range.</b>	
Is the gas inlet/outlet pressure differential either too high or too low?  NOTE: If the differential pressure is too high, voltage to the will be zero, which is abnormally low for the setpoint. If the differential is too low, voltage to will be at its maximum value, which is abnormally high for the set-point.	Verify that the pressure is correct for the gas and range. If required, adjust inlet/outlet pressure to achieve proper pressure reading.
Is the MOD LED light on the GF100 Series lit solid green?	Observe the LED display panel at top of . If the LED light is not lit, cycle power the to reboot.
Is the setpoint correct for the required gas flow?	Use the tool software to verify.
Is the calibrated for the particular gas?	Check the side label. Run a flow check to verify.
Is the zero correct?	Zero the according to zeroing procedure in Section 2-14. Verify leak check rates are OK.
<b>3. No gas control; flow is at or above maximum.</b>	
Is the gas pressure across the too high?	Verify that the pressure is correct for the gas and range. If required, adjust inlet/outlet pressure to achieve proper pressure reading.
Are system valves open, or is the purge input activated?	Use tool software to verify.
Is the setpoint correct for the required flow?	Use tool software to verify.

## Section 4 Maintenance & Troubleshooting

Table 4-2 GF100 Series Troubleshooting Guide (Continued)

Symptoms & Possible Causes	Corrective Action
<b>4. No gas flow above some set-point.</b>	
<p>NOTE: When the setpoint is increased beyond this point, the GF100 Series signal remains at some value lower than the set-point.</p> <p>Is the gas inlet/outlet differential pressure sufficient?</p> <p>NOTE: If the pressure reading is too low, the valve voltage to the GF100 Series will be at its maximum output. This condition will cause internal GF valve heating and inability to properly reach desired flow setpoints.</p>	<p>Verify that the pressure is correct for the gas and range. If required, adjust regulator to achieve proper pressure</p>
<p>Is the GF100 Series calibrated for the gas flow?</p>	<p>Check GF100 Series side label. Run a flow check to verify. If flow is incorrect, replace the GF100 Series with a unit that is calibrated properly.</p>
<b>5. No gas flow below some set-point.</b>	
<p>NOTE: When the setpoint is decreased below this point, the GF100 Series signal remains at some value higher than the setpoint.</p> <p>Is the gas inlet/outlet differential pressure too high, or above published setpoints?</p> <p>NOTE: If the differential pressure reading is too high, voltage to the GF100 Series will be at its maximum value when the setpoint is decreased below the point where flow decreases.</p>	<p>Verify that the pressure is correct for this gas and range. If required, adjust regulator to achieve proper pressure</p>
<p>Is the GF100 Series leaking?</p>	<p>Check for contamination. Test the GF100 Series for leak integrity. Replace the Unit GF100 Series if leakage is detected.</p>
<b>6. Gas flow, or GF100 Series pressure reading oscillates.</b>	
<p>Is the GF100 Series calibrated for the gas flowing?</p>	<p>Check the GF100 Series side can label. Run a flow check to verify. If flow is incorrect, replace the GF100 Series.</p>
<p>Is there too much gas pressure across the GF100 Series?</p>	<p>Verify that the pressure is correct for this gas and range. If required, adjust regulator to achieve proper pressure reading.</p>

## Section 4 Maintenance & Troubleshooting

Table 4-2 GF100 Series Troubleshooting Guide (Continued)

Symptoms & Possible Causes	Corrective Action
<p><b>6. Gas flow, or GF100 Series pressure reading oscillates.</b></p>	
<p>Are inlet and outlet pressures stable?</p> <p>NOTE: Most GF100 Series calibrated with nitrogen will oscillate with hydrogen or helium.</p>	<p>If outlet pressure is unstable, check for (no oscillation or hunting) a faulty vacuum pump, or hunting at a downstream valve.</p> <p>Check inlet pressure on tool. A faulty pressure regulator can make the GF100 Series appear to oscillate.</p> <p>Adjust inlet pressure up or down by 2 psig increments until hunting disappears. Verify common gas pressure is within range.</p> <p>NOTE: Hunting or oscillation can be contributed to multiple GF100 Series sharing a common gas manifold. Therefore, inspect gas delivery sources to the gas box. (for example; two tools sharing a common gas bottle and calling for gas at the same time.) Valve leak. Unregulated gas pressure from Facilities.</p>
<p><b>7. GF100 Series does not read zero pressure when gas is shut off.</b></p>	
<p>Is the differential pressure across the GF100 Series really zero?</p> <p>Is the GF100 Series configured properly in the tool software?</p> <p>Is the GF100 Series mounted to the proper attitude?</p>	<p>Verify that the pressure is correct for the gas and range. If the GF100 Series has been contaminated, it may not be able to close, and therefore, will not zero. Equalize the pressure across the GF100 Series by opening it briefly. Set up the GF100 Series for zeroing. Then perform the zeroing procedure in Section 2-14. Use the tool software to verify.</p> <p>Refer to the side can label on the GF100 Series. The GF100 Series should be calibrated in the attitude it will be operating at.</p>
<p><b>8. OEM tool does not read correct GF100 Series zero reading.</b></p>	
<p>Is the differential pressure across the GF100 Series really zero?</p> <p>Is the supply voltage within specified range?</p> <p>Is the GF100 Series mounted in the proper attitude?</p> <p>Is the flow output signal of the GF100 Series really zero?</p>	<p>GF100 Series valve leakage. Incorrect MFC zero.</p>
<p><b>9. Zero Drift.</b></p>	
<p>Improper zero of the GF100 Series? Excessive Valve leakage?</p>	<p>GF100 Series aging or sensor stabilization. Zero is not correct.</p>

## Section 4 Maintenance & Troubleshooting

Table 4-2 GF100 Series Troubleshooting Guide (Continued)

Symptoms & Possible Causes	Corrective Action
<b>10. Calibration Drift.</b>	
Gas box temperature too high? Is it linear offset?	Zero is not correct.
<b>11. GF100 Series indicates Overshoot.</b>	
	If the tool is idle for an extended period of time, high inlet pressure or contamination will cause overshoot on first use.
<b>12. OEM tool indicates the wrong full scale value for GF100 Series.</b>	
	Older version of Multiflo Configurator used to program GF100 Series.
<b>13. GF100 Series dumps large volume of gas into chamber when setpoint is commanded from the tool.</b>	
	The tool is commanding a setpoint before the pneumatic valves are opened. GF100 Series and pneumatic timing may be offset. GF100 Series overshoots.
<b>14. Tool display output doesn't match GF100 Series flow output.</b>	
Cable resistance causing offset in the tool's display.	Check GF100 Series zero.

## Section 5 Product Description Code

### Overview

Reference Tables 5-1 through 5-5 for specific Product Description Codes.

Table 5-1 GF100, GF120 & GF125 Series Product Description Code

Code Description	Code Option	Option Description
<b>I.</b> Base Model Code	<b>GF</b>	High Purity/Ultra High Purity Digital Mass Flow Controllers
<b>II.</b> Package / Finish Specifications	<b>100</b>	Flow range 3 sccm -55 slpm N <sub>2</sub> Eq.; ± 1.0% SP Accuracy; 1 sec Response; 10 Ra
	<b>120</b>	Flow range 3 sccm -55 slpm N <sub>2</sub> Eq.; + 1.0% SP Accuracy; 700 msec Response; 4 Ra
	<b>125</b>	Pressure Transient Insensitive (PTI) Flow range 3 sccm -55 slpm N <sub>2</sub> Eq.; + 1.0% SP Accuracy; 300-700 msec Response; 4 Ra
<b>III.</b> Configurability	<b>C</b>	MultiFlo capable. Standard bins or specific gas/range may be selected.
	<b>X</b>	Not MultiFlo capable. Specific gas/range required. (must select w/ SD, SL or HA special application)
<b>IV.</b> Special Application	<b>XX</b>	Standard
	<b>SL</b>	Safe Delivery System (GF120 Only) Full scale flow range; 4 to 25 sccm, Nitrogen Equivalent
	<b>SD</b>	Safe Delivery System (GF120 Only) Full scale flow range; >25 sccm to 1 slpm, Nitrogen Equivalent
<b>V.</b> Valve Configuration	<b>O</b>	Normally Open valve (not available with SD, SL or HA options)
	<b>C</b>	Normally Closed valve (must select with SD, SL or HA special application)
	<b>M</b>	Meter (No Valve)
<b>VI.</b> Gas or SH MultiFlo Bin	<b>XXXX XXXX</b>	Specific Gas Code & Range, i.e. "0004" = Argon and "010L" = 10 slpm (must select w/ SD, SL or HA special application).
	<b>SH40 010C</b>	Standard Configuration #40, 3-10 sccm Nitrogen Equivalent (0° C Reference)
	<b>SH41 030C</b>	Standard Configuration #41, 11-30 sccm Nitrogen Equivalent (0° C Reference)
	<b>SH42 092C</b>	Standard Configuration #42, 31-92 sccm Nitrogen Equivalent (0° C Reference)
	<b>SH43 280C</b>	Standard Configuration #43, 93-280 sccm Nitrogen Equivalent (0° C Reference)
	<b>SH44 860C</b>	Standard Configuration #44, 281-860 sccm Nitrogen Equivalent (0° C Reference)
	<b>SH45 2.6L</b>	Standard Configuration #45, 861-2600 sccm Nitrogen Equivalent (0° C Reference)
	<b>SH46 7.2L</b>	Standard Configuration #46, 2601-7200 sccm Nitrogen Equivalent (0° C Reference)
	<b>SH47 015L</b>	Standard Configuration #47, 7201-15000 sccm Nitrogen Equivalent (0° C Reference)
	<b>SH48 030L</b>	Standard Configuration #48, 15001-30000 sccm Nitrogen Equivalent (0° C Reference)
	<b>SH49 040L</b>	Standard Configuration #49, 30001-40000 sccm Nitrogen Equivalent (0° C Reference)
<b>SH50 055L</b>	Standard Configuration #50, 40001-55000 sccm Nitrogen Equivalent (0° C Reference)	
<b>VII.</b> Fitting	<b>VX</b>	1-1/2" body width, 124mm 1/4" VCR male
	<b>VS</b>	1-1/8" body width, 124mm 1/4" VCR male
	<b>CX</b>	1-1/8" body width, 92mm C Seal
	<b>DX</b>	1-1/8" body width, 79.8mm C Seal
	<b>EX</b>	1-1/2" body width, 79.8mm W Seal
	<b>WX</b>	1-1/8" body width, 92mm W Seal
	<b>YX</b>	1-1/8" body width, 79.8mm W Seal
	<b>AX</b>	1-1/2" body width, 92mm C Seal
	<b>BX</b>	1-1/2" body width, 92mm W Seal
	<b>LX</b>	1-1/8" body width, 92mm C Seal w/Poke Yoke
	<b>AS</b>	1-1/2" body width, 92mm 0.440" large bore C Seal (only for bins SH45-SH50)
<b>VIII.</b> Downstream Condition	<b>A</b>	Atmosphere
	<b>V</b>	Vacuum; Default for SD, SL and HA special application
<b>IX.</b> Sensor	<b>O</b>	Default Sensor Orientation

*Model Code continued on next page.*

## Section 5 Product Description Code

Table 5-1 GF100, GF120 & GF125 Series Product Description Code (Continued)

Code Description	Code Option	Option Description									
X. Connector	<b>BX</b>	Cable adapter to 15 pin D Brooks (Unit "B", "N") adapts G1 base									
	<b>EX</b>	Cable adapter to Card Edge (w/out VTP), RS485 through RJ11 jacks (Unit "E"; IN "L", "R") adapts GX base (Not Available on 79.8mm fitting DX, YX, EX)									
	<b>FX</b>	Cable adapter with 9 pin STEC pin-out & jack screws (w/VTP) (Unit "F", "O") adapts SX base									
	<b>GX</b>	9-Pin D with RS485 (Unit "G"); display and overlay 180° orientation (Not Available on 79.8mm fitting DX, YX, EX)									
	<b>G1</b>	9-Pin D with RS485 (Unit "G") (Not Available on 79.8mm fitting DX, YX, EX)									
	<b>JX</b>	Cable adapter with 9 pin STEC pin-out & jack screws (w/VTP) (Unit "J", "W") adapts SX base									
	<b>KX</b>	Cable adapter to MKS 15-Pin D (Unit "K") adapts G1 base									
	<b>SX</b>	9 pin D with STEC pin-out (w/VTP) (Unit "S", "Q")									
	<b>TX</b>	9 pin D with UDT9 pin-out (UDT9)									
	<b>T1</b>	Cable adapter to 15 pin D (IFlow DB15 & TN 15 pin) adapts TX base (Not Available on 79.8mm fitting DX, YX, EX)									
	<b>UX</b>	Cable adapter to 15 pin D (w/VTP) (Unit & TN "U") adapts SX base									
	<b>BB</b>	DeviceNet™ Analog (Not Available on 79.8mm fitting DX, YX, EX)									
	DeviceNet Standard Configuration Parameters										
		I/O	Connector	Power On State	Full Scale Setting	Full Scale Setting	Full Scale Setting	Poll IO Instance Producer	Poll IO Instance Consumer	Poll IO State Transition	External Baud Rate
	<b>D0</b>	DeviceNet	5 Pin Micro	Idle	Count	Integer	6000h	2	7	Executing	500KB
	<b>D1</b>	DeviceNet	5 Pin Micro	Idle	Count	Integer	6000h	21	7	Executing	500KB
	<b>D2</b>	DeviceNet	5 Pin Micro	Idle	SCCM	Float	7FFFh	13	19	Executing	500KB
	<b>D3</b>	DeviceNet	5 Pin Micro	Idle	Count	Integer	6000h	22	7	Executing	500KB
	<b>D4</b>	DeviceNet	5 Pin Micro	Executing	Count	Integer	6000h	22	8	Executing	500KB
	<b>D5</b>	DeviceNet	5 Pin Micro	Idle	Count	Integer	6000h	6	8	Executing	500KB
<b>D6</b>	DeviceNet	5 Pin Micro	Idle	Count	Integer	7FFFh	3	7	Executing	500KB	
<b>D7</b>	DeviceNet	5 Pin Micro	Idle	Count	Integer	7FFFh	6	8	Executing	500KB	
<b>D8</b>	DeviceNet	5 Pin Micro	Idle	Count	Integer	6000h	3	7	Executing	500KB	
<b>D9</b>	DeviceNet	5 Pin Micro	Executing	Count	Integer	6000h	2	7	Executing	500KB	
<b>DA</b>	DeviceNet	5 Pin Micro	Idle	Count	Integer	7FFFh	22	7	Executing	500KB	
<b>DB</b>	DeviceNet	5 Pin Micro	Idle	Count	Integer	6000h	22	8	Executing	500KB	
<b>DC</b>	DeviceNet	5 Pin Micro	Idle	Count	Integer	7FFFh	3	7	Idle	500KB	
<b>DD</b>	DeviceNet	5 Pin Micro	Executing	Count	Integer	7FFFh	22	8	Executing	500KB	
<b>DE</b>	DeviceNet	5 Pin Micro	Executing	Sccm	Float	6000h	15	19	Executing	500KB	
<b>DX</b>	DeviceNet	5 Pin Micro	To be defined by CSR								

Code Description	Code Option	Option Description
<b>XI.</b> Customer Special Request	<b>XXXX</b>	Customer Special Request Number; required with "DX, BB" Conn. Option to define DNet settings
<b>XII.</b> Auto Shut-Off	<b>A</b>	Auto Shut-Off (Included) Default for SD and SL special application
	<b>X</b>	Auto Shut-Off (Not Included) (Must be selected for meter)
<b>XIII.</b> Auto Zero	<b>X</b>	Auto Zero (Not Included)
<b>XIV.</b> Reference Temperature	<b>000</b>	0°C Reference Calibration (Standard) - Default Setting

### Sample Standard Model Code

I	II	III	IV	V	VI	VII	VIII	IX	X	XI	XII	XIII	XIV
GF	100	C	XX	M	- SH40010C	- VX	A	0	GX	- XXXX	A	X	- 000

### Sample Safe Delivery System (SDS) Model Code

I	II	III	IV	V	VI	VII	VIII	IX	X	XI	XII	XIII	XIV
GF	120	X	SD	C	- XXXXXXXX	- EX	V	0	SX	- XXXX	A	X	- 000

## Section 5 Product Description Code

Table 5-2 GF100, GF120 & GF125 Series with EtherCAT Communications Product Description Code

Code Description	Code Option	Option Description
<b>I.</b> Base Model Code	<b>GF</b>	High Purity/Ultra High Purity Digital Mass Flow Controllers
<b>II.</b> Package / Finish Specifications	<b>100</b>	Flow range 3 sccm - 55 slpm N2 Equivalent.; 1 sec Response; 10 Ra
	<b>120</b>	Flow range 3 sccm - 55 slpm N2 Equivalent.; 700 msec Response; 5 Ra
	<b>125</b>	Pressure Transient Insensitive (PTI) Flow range 3 sccm -55 slpm N2 Equivalent; 300-700 msec Response; 5 Ra
<b>III.</b> Configurability	<b>C</b>	MultiFlo capable. Standard bins or specific gas/range may be selected.
	<b>X</b>	Not MultiFlo capable. Specific gas/range required. (must select w/ SD or SL special application)
<b>IV.</b> Special Application	<b>XX</b>	Standard
	<b>SL</b>	Safe Delivery System (GF120 Only) Full scale flow range; 4 to 25 sccm, N2 Equivalent
	<b>SD</b>	Safe Delivery System (GF120 Only) Full scale flow range; 25 sccm to 1 slpm, N2 Equivalent
<b>V.</b> Valve Configuration	<b>O</b>	Normally Open valve (not available with SD, SL or VS options)
	<b>C</b>	Normally Closed valve
	<b>M</b>	Meter (No Valve)
<b>VI.</b> Gas or SH MultiFlo Bin	<b>XXXX XXXX</b>	Specific Gas Code & Range, i.e. "0004" = Argon and "010L" = 10 slpm
	<b>SH40 010C</b>	Standard Configuration #40, 3-10 sccm Nitrogen Equivalent
	<b>SH41 030C</b>	Standard Configuration #41, 11-30 sccm Nitrogen Equivalent
	<b>SH42 092C</b>	Standard Configuration #42, 31-92 sccm Nitrogen Equivalent
	<b>SH43 280C</b>	Standard Configuration #43,93-280 sccm Nitrogen Equivalent
	<b>SH44 860C</b>	Standard Configuration #44, 281-860 sccm Nitrogen Equivalent
	<b>SH45 2.6L</b>	Standard Configuration #45, 861-2600 sccm Nitrogen Equivalent
	<b>SH46 7.2L</b>	Standard Configuration #46, 2601-7200 sccm Nitrogen Equivalent
	<b>SH47 015L</b>	Standard Configuration #47, 7201-15000 sccm Nitrogen Equivalent
	<b>SH48 030L</b>	Standard Configuration #48, 15001-30000 sccm Nitrogen Equivalent
	<b>SH49 040L</b>	Standard Configuration #49, 30001-40000 sccm Nitrogen Equivalent
<b>SH50 055L</b>	Standard Configuration #50, 40001-55000 sccm Nitrogen Equivalent	
<b>VII.</b> Fitting	<b>VS</b>	1-1/8" body width, 1/4" VCR male
	<b>VX</b>	1-1/2" body width, 1/4" VCR male
	<b>CX</b>	1-1/8" body width, C Seal 92mm
	<b>WX</b>	1-1/8" body width, W Seal 92mm
<b>VIII.</b> Downstream Condition	<b>A</b>	Atmosphere
	<b>V</b>	Vacuum
<b>IX.</b> Sensor	<b>O</b>	Default Sensor Orientation
<b>X.</b> Connector	<b>E0</b>	EtherCAT Communication
<b>XI.</b> Customer Special Request	<b>XXXX</b>	Customer Special Request Number
<b>XII.</b> Auto Shut-Off	<b>A</b>	Auto Shut-Off (Included)
	<b>X</b>	Auto Shut-Off (Not Included)
<b>XIII.</b> Auto Zero	<b>X</b>	Auto Zero (Not Included)
<b>XIV.</b> Reference Temperature	<b>000</b>	0 deg C Reference Calibration (Standard) - Default Setting

## Section 5 Product Description Code

Table 5-3 Model GF135 Product Description Code

Code Description	Code Option	Option Description									
<b>I. Base Model Code</b>	<b>GF</b>										
<b>II. Package/Finish Specifications</b>	<b>135</b>	Pressure Transient Insensitive (PTI) Ultra High Purity Advanced Diagnostic MFC									
<b>III. Configurability</b>	<b>X</b>	Gas specific									
<b>IV. Special Application</b>	<b>XX</b>	Standard Application									
<b>V. Valve Configuration</b>	<b>C</b>	Normally Closed Valve									
<b>VI. Specific Gas Code &amp; Range</b>	<b>XXXX XXXX</b>	Specify Gas Code & Range, i.e. "0004" = Argon and "010L" = 10 slpm									
<b>VII. Fitting</b>	<b>VX</b>	1 1/2" VCR 1/4"									
	<b>CX</b>	1 1/8" C Seal 92mm									
	<b>WX</b>	1 1/8" W Seal 92mm (FUTURE RELEASE)									
<b>VIII. Downstream Condition</b>	<b>A</b>	Atmosphere									
	<b>V</b>	Vacuum									
<b>IX. Sensor</b>	<b>O</b>	Default Orientation									
<b>X. Connector</b>	DeviceNet Standard Configuration Parameters										
		I/O	Connector	Power On State	Full Scale Setting	Full Scale Setting	Full Scale Setting	Poll IO Instance Producer	Poll IO Instance Consumer	Poll IO State Transition	External Baud Rate
	<b>D0</b>	DeviceNet	5 Pin Micro	Idle	Count	Integer	6000h	2	7	Executing	500KB
	<b>D1</b>	DeviceNet	5 Pin Micro	Idle	Count	Integer	6000h	21	7	Executing	500KB
	<b>D2</b>	DeviceNet	5 Pin Micro	Idle	SCCM	Float	7FFFh	13	19	Executing	500KB
	<b>D3</b>	DeviceNet	5 Pin Micro	Idle	Count	Integer	6000h	22	7	Executing	500KB
	<b>D4</b>	DeviceNet	5 Pin Micro	Executing	Count	Integer	6000h	22	8	Executing	500KB
	<b>D5</b>	DeviceNet	5 Pin Micro	Idle	Count	Integer	6000h	6	8	Executing	500KB
	<b>D6</b>	DeviceNet	5 Pin Micro	Idle	Count	Integer	7FFFh	3	7	Executing	500KB
	<b>D7</b>	DeviceNet	5 Pin Micro	Idle	Count	Integer	7FFFh	6	8	Executing	500KB
	<b>D8</b>	DeviceNet	5 Pin Micro	Idle	Count	Integer	6000h	3	7	Executing	500KB
	<b>D9</b>	DeviceNet	5 Pin Micro	Executing	Count	Integer	6000h	2	7	Executing	500KB
	<b>DA</b>	DeviceNet	5 Pin Micro	Idle	Count	Integer	7FFFh	22	7	Executing	500KB
	<b>DB</b>	DeviceNet	5 Pin Micro	Idle	Count	Integer	6000h	22	8	Executing	500KB
	<b>DC</b>	DeviceNet	5 Pin Micro	Idle	Count	Integer	7FFFh	3	7	Idle	500KB
	<b>DD</b>	DeviceNet	5 Pin Micro	Executing	Count	Integer	7FFFh	22	8	Executing	500KB
<b>DE</b>	DeviceNet	5 Pin Micro	Executing	SCCM	Float	6000h	15	19	Executing	500KB	
<b>DX</b>	DeviceNet	5 Pin Micro	To be defined by CSR								
<b>G2</b>	Analog/RS485	9 Pin D	NA	NA	NA	NA	NA	NA	NA	NA	
<b>XI. Customer Special Request</b>	<b>XXXX</b>	Customer Special Request Number									
<b>XII. Auto Shut-Off</b>	<b>A</b>	Auto Shut Off (Included)									
	<b>X</b>	Auto Shut Off (Not Included)									
<b>XIII. Auto Zero</b>	<b>A</b>	Auto Zero (Included)									
	<b>X</b>	Auto Zero (Not Included)									
<b>XIV. Reference Temperature</b>	<b>000</b>	0°C Reference Calibration (Standard) - Default Setting									

### Example Model Code

I	II	III	IV	V	VI	VII	VIII	IX	X	XI	XII	XIII	XIV
GF	135	X	XX	C	XXXX XXXX	VX	A	O	D1	XXXX	A	A	000



## Section 5 Product Description Code

Table 5-4 GF101, GF121 & GF126 Series Product Description Code

Code Description	Code Option	Option Description									
<b>I.</b> Base Model Code	<b>GF</b>	High Purity/Ultra High Purity Digital Mass Flow Controllers									
<b>II.</b> Package / Finish Specifications	<b>101</b>	Flow range 55 - 300 slm N <sub>2</sub> Eq.; 10 Ra HP wetted flow path									
	<b>121</b>	Flow range 55 - 300 slm N <sub>2</sub> Eq. 5 Ra UHP wetted flow path									
	<b>126</b>	Flow range 55 - 300 slm N <sub>2</sub> Eq. 5 Ra UHP wetted flow path & integrated pressure measurement									
<b>III.</b> Configurability	<b>C</b>	MultiFlo capable									
	<b>X</b>	Not configurable									
<b>IV.</b> Special Application	<b>XX</b>	Standard									
<b>V.</b> Valve Configuration	<b>C</b>	Normally Closed valve									
	<b>M</b>	Meter (No Valve)									
<b>VI.</b> Gas or SH MultiFlo Bin	<b>XXXX XXXX</b>	Specific Gas Code & Range, i.e. "0004" = Argon and "100L" = 100 slpm									
	<b>SH51 055L</b>	Standard Configuration #51, 55,001 sccm N <sub>2</sub> Equivalent (0°C Reference) Special Bin for low density gases, e.g. 73,002-120,000 He, 100,002-170,000 H <sub>2</sub>									
	<b>SH52 100L</b>	Standard Configuration #52, 55,002-100,000 sccm N <sub>2</sub> Equivalent (0°C Reference)									
	<b>SH53 200L</b>	Standard Configuration #53, 100,001-200,000 sccm N <sub>2</sub> Equivalent (0°C Reference)									
	<b>SH54 300L</b>	Standard Configuration #54, 200,001-300,000 N <sub>2</sub> Equivalent (0°C Reference)									
<b>VII.</b> Fitting	<b>V1</b>	1-1/2" body width, 134mm 1/2" VCR male (See Accessories on Page 3 for VCR lay length adapters)									
	<b>V2</b>	1-1/2" body width, 150.4mm 1/2" VCR male									
	<b>V3</b>	1-1/2" body width, 166mm 1/2" VCR male									
	<b>V4</b>	1-1/2" body width, 168.6mm 1/2" VCR male									
	<b>C1</b>	1-1/2" body width, 92mm 3/8" C Seal									
	<b>C2</b>	1-1/2" body width, 114mm 3/8" C Seal									
<b>VIII.</b> Downstream Condition	<b>A</b>	Atmosphere									
	<b>V</b>	Vacuum									
<b>IX.</b> Sensor	<b>O</b>	Default Sensor Orientation									
<b>X.</b> Connector	<b>BX</b>	Cable adapter to 15 pin D Brooks (Unit "B", "N")									
	<b>EX</b>	Cable adapter to card edge (w/out VTP), RS485 through RJ11 jacks (Unit "E"; IN "L", "R"); display and overlay 180° orientation									
	<b>FX</b>	Cable adapter with 9 pin STEC pin-out & jack screws (w/VTP) (Unit "F", "O")									
	<b>G1</b>	9-Pin D with RS485 (Unit "G")									
	<b>JX</b>	Cable adapter with 9 pin STEC pin-out & jack screws (w/VTP) (Unit "J", "W")									
	<b>KX</b>	Cable adapter to MKS 15-Pin D (Unit "K")									
	<b>SX</b>	9 pin D with STEC pin-out (w/VTP) (Unit "S", "Q")									
	<b>UX</b>	Cable adapter to 15 pin D (w/VTP) (Unit & TN "U")									
		DeviceNet Standard Configuration Parameters									
		I/O	Connector	Power On State	Full Scale Setting	Full Scale Setting	Full Scale Setting	Poll IO Instance Producer	Poll IO Instance Consumer	Poll IO State Transition	External Baud Rate
	<b>D0</b>	DeviceNet	5 Pin Micro	Idle	Count	Integer	6000h	2	7	Executing	500KB
	<b>D1</b>	DeviceNet	5 Pin Micro	Idle	Count	Integer	6000h	21	7	Executing	500KB
	<b>D2</b>	DeviceNet	5 Pin Micro	Idle	SCCM	Float	7FFFh	13	19	Executing	500KB
	<b>D3</b>	DeviceNet	5 Pin Micro	Idle	Count	Integer	6000h	22	7	Executing	500KB
	<b>D4</b>	DeviceNet	5 Pin Micro	Executing	Count	Integer	6000h	22	8	Executing	500KB
	<b>D5</b>	DeviceNet	5 Pin Micro	Idle	Count	Integer	6000h	6	8	Executing	500KB
	<b>D6</b>	DeviceNet	5 Pin Micro	Idle	Count	Integer	7FFFh	3	7	Executing	500KB
	<b>D7</b>	DeviceNet	5 Pin Micro	Idle	Count	Integer	7FFFh	6	8	Executing	500KB
	<b>D8</b>	DeviceNet	5 Pin Micro	Idle	Count	Integer	6000h	3	7	Executing	500KB
	<b>D9</b>	DeviceNet	5 Pin Micro	Executing	Count	Integer	6000h	2	7	Executing	500KB
	<b>DA</b>	DeviceNet	5 Pin Micro	Idle	Count	Integer	7FFFh	22	7	Executing	500KB
	<b>DB</b>	DeviceNet	5 Pin Micro	Idle	Count	Integer	6000h	22	8	Executing	500KB
	<b>DC</b>	DeviceNet	5 Pin Micro	Idle	Count	Integer	7FFFh	3	7	Idle	500KB
	<b>DD</b>	DeviceNet	5 Pin Micro	Executing	Count	Integer	7FFFh	22	8	Executing	500KB
	<b>DE</b>	DeviceNet	5 Pin Micro	Executing	SCCM	Float	6000h	15	19	Executing	500KB
	<b>DX</b>	DeviceNet	5 Pin Micro	To be defined by CSR							
	<b>XI.</b> Customer Special Request	<b>XXXX</b>	Customer Special Request Number								
<b>XII.</b> Auto Shut-Off	<b>A</b>	Auto Shut-Off (Included)									
	<b>X</b>	Auto Shut-Off (Not Included) (Must be selected for meter)									
<b>XIII.</b> Auto Zero	<b>A</b>	Auto Zero (Included)									
	<b>X</b>	Auto Zero (Not Included)									
<b>XIV.</b> Reference Temperature	<b>000</b>	0°C Reference Calibration (Standard) - Default Setting									

**Sample Standard Model Code**

<b>I</b>	<b>II</b>	<b>III</b>	<b>IV</b>	<b>V</b>	<b>VI</b>	<b>VII</b>	<b>VIII</b>	<b>IX</b>	<b>X</b>	<b>XI</b>	<b>XII</b>	<b>XIII</b>	<b>XIV</b>
<b>GF</b>	<b>101</b>	<b>C</b>	<b>XX</b>	<b>C</b>	<b>- SH52 100L</b>	<b>- V1</b>	<b>A</b>	<b>0</b>	<b>G1</b>	<b>- XXXX</b>	<b>A</b>	<b>X</b>	<b>- 000</b>

## Section 5 Product Description Code

Table 5-5 GF101, GF121 & GF126 Series with EtherCAT Communications Product Description Code

Code Description	Code Option	Option Description
<b>I.</b> Base Model Code	<b>GF</b>	High Purity/Ultra High Purity Digital Mass Flow Controllers
<b>II.</b> Package / Finish Specifications	<b>101</b>	Flow range 55 - 300 slm N2 Equivalent.; 10 Ra HP wetted flow path
	<b>121</b>	Flow range 55 - 300 slm N2 Equivalent 5 Ra HP wetted flow path
	<b>126</b>	Flow range 55 - 300 slm N2 Equivalent 5 Ra HP wetted flow path & integrated pressure measurement
<b>III.</b> Configurability	<b>C</b>	MultiFlo capable. Standard bins or specific gas/range may be selected
	<b>X</b>	Not MultiFlo capable. Specific gas/range required
<b>IV.</b> Special Application	<b>XX</b>	Standard
<b>V.</b> Valve Configuration	<b>C</b>	Normally Closed valve
	<b>M</b>	Meter (No Valve)
<b>VI.</b> Gas or SH MultiFlo Bin	<b>XXXX XXXX</b>	Specific Gas Code & Range, i.e. "0004" = Argon and "010L" = 10 slpm
	<b>SH51 055L</b>	Standard Configuration #51, 55,001 sccm N2 Equivalent (0°C Reference)
	<b>SH52 100L</b>	Standard Configuration #52, 55,002-100,000 sccm N2 Equivalent (0°C Reference)
	<b>SH53 200L</b>	Standard Configuration #53, 100,001-200,000 sccm N2 Equivalent (0°C Reference)
	<b>SH54 300L</b>	Standard Configuration #54, 200,001-300,000 N2 Equivalent (0°C Reference)
<b>VII.</b> Fitting	<b>V1</b>	1-1/2" body width, 134mm 1/2" VCR male
	<b>C1</b>	1-1/2" body width, 92mm C Seal
	<b>C2</b>	1-1/2" body width, 114mm C Seal
<b>VIII.</b> Downstream Condition	<b>A</b>	Atmosphere
	<b>V</b>	Vacuum
<b>IX.</b> Sensor	<b>O</b>	Default Sensor Orientation
<b>X.</b> Connector	<b>E0</b>	EtherCAT Communication
<b>XI.</b> Customer Special Request	<b>XXXX</b>	Customer Special Request (CSR) Number
<b>XII.</b> Auto Shut-Off	<b>A</b>	Auto Shut-Off (Included)
	<b>X</b>	Auto Shut-Off (Not Included)
<b>XIII.</b> Auto Zero	<b>X</b>	Auto Zero (Not Included)
<b>XIV.</b> Reference Temperature	<b>000</b>	0°C Reference Calibration (Standard) - Default Setting

### GF100 Series Ordering Instructions

Refer to the Product Description Codes on the previous pages. Starting from the left, choose the product code options as follows:

1. Required performance model.
  - a. Standard Performance, non-PTI: **GF100**
  - b. High Performance, non-PTI: **GF120**
  - c. High Performance, w/ PTI: **GF125**
  - d. High Performance, w/ PTI, w/ROD: **GF135**
  - e. Standard Performance, High Flow, Non-PTI: **GF101**
  - f. High Performance, High Flow, Non-PTI: **GF121**
  - g. High Performance, High Flow, w/PTI: **GF126**
2. Configurability
  - a. Disabled: **X**
  - b. Enabled: **C**, Standard (not an option for GF135)
3. Specialty Application
  - a. Safe Delivery, for GF120 only: **SD**
  - b. No Specialty App: **XX**
4. Valve Configuration
  - a. Normally Closed: **C**
  - b. Normally Open: **O**
  - c. Meter: **M**
5. Gas or SH MultiFlo Bin
  - a. If Gas Specific, enter SEMI gas code: ex. **0013**, for N2
  - b. If SH MultiFlow Bin: **SHnn**, nn being the required SHBin, 40 - 50 or 51 - 54 (High Flow)
6. Maximum Flow
  - a. If Gas Specific, enter maximum range in sccm, "C" or slm "L": ex. **500C**
  - b. If SH Bin, enter defined maximum flow: ex. **860**, choosing SH44, 281 - 860 sccm
7. Fitting
  - a. Enter 2-character option code as defined: ex. **CX**, 1 1/8" C Seal 92mm
8. Downstream Condition
  - a. Outlet to Vacuum: **V**
  - b. Outlet to Atmosphere: **A**
9. Sensor
  - a. Orthogonal: **O**, this is default, non-selectable
10. Connector
  - a. Enter 2-character option code as defined: ex. **DX**, DeviceNet
11. CSR
  - a. Customer Special Requirement, contact Brooks Apps Engineering for review of requirement and creation of CSR: **nnnn**
  - b. If DNET connector, CSR required to define DNET attributes: **0924**, generic, ODVA Std. configuration
  - c. None Required: **XXXX**
12. Auto Shut-Off.
  - a. Enabled: **A**
  - b. Disabled: **X**
13. Auto Zero
  - a. Disabled: **X**
14. Reference Temperature, Operating Temperature in Degrees C
  - a. 0°C Reference Calibration (Standard): **000**, default

Here is an example of a configured Product Description Code (PDC) for a GF125, Configurable, no Specialty Application, Valve Normally Closed, MultiFlo for 281-860 sccm, 1 1/8" C Seal 92mm, outlet to Vacuum, default sensor, DNET, no CSR, Auto Shut Off enabled, Auto Zero disabled and Default Reference Temperature:  
**GF125CXXC-SH44860C-CXVODX-0924AX-000**

# Appendix A: GF100 Series Gas Table

## GF100 Series Gas Table

### Table A-1 GF100 Series Gas Table

(Reference the following pages, A-1 and A-2).

*Table A-1A GF100 Series Gas Table - Codes 1-108, Bins SH40 to SH50*

Gas Code	Gas Symbol	Gas Name	Min inlet pressure for vac. exhaust (PSIA)																															
			SH40-SH47				SH48		SH49		SH50		SH40		SH41		SH42		SH43		SH44		SH45		SH46		SH47		SH48		SH49		SH50	
1	He	Helium	19.7	24.7	29.7					5	14	15	42	43	129	129	400	401	1194	1195	3609	3610	11100	11101	23100	23101	47000	47001	100000					
2	Ne	Neon	24.7							5	14	15	42	43	129	130	400	401	1207	1208	3650	3651	10700	10701	22100									
4	Ar	Argon	24.7	29.7	39.7	44.7				5	14	15	42	43	130	131	400	401	1214	1215	3671	3672	10000	10001	20200	20201	41000	41001	42000	42001	55000			
5	Kr	Krypton	29.7							4	11	12	32	33	100	101	300	301	930	931	2800	2801	7160	7161	14900									
6	Xe	Xenon	24.7							3	6	7	19	20	58	59	178	179	546	547	1651	1652	4210	4211	8760									
7	H2	Hydrogen	14.7	14.7	19.7					3	10	11	30	31	92	93	280	281	860	861	2600	2601	8000	8001	16400	16401	33000	33001	73000					
8	Air	Air	24.7	29.7						3	10	11	30	31	92	93	280	281	860	861	2600	2601	7400	7401	15000	15001	30000							
9	CO	Carbon Monoxide	24.7	29.7						3	10	11	30	31	92	93	280	281	860	861	2600	2601	7300	7301	15000	15001	30000							
10	HBr	Hydrogen Bromide	24.7							3	8	9	25	26	77	78	235	236	723	724	2187	2188	5610	5611	11700									
11	HCl	Hydrogen Chloride	24.7	29.7						3	10	11	30	31	92	93	280	281	860	861	2600	2601	6900	6901	14200	14201	29000							
12	HF	Hydrogen Fluoride	14.7	17.7						3	10	11	30	31	94	95	281	282	880	881	2610	2611	7400	7401	15000	15001	30000							
13	N2	Nitrogen	24.7	29.7	29.7	32.7				3	10	11	30	31	92	93	280	281	860	861	2600	2601	7200	7201	15000	15001	30000	30001	40000	40001	55000			
14	D2	Deuterium	14.7	14.7						3	10	11	30	31	94	95	280	281	880	881	2600	2601	8100	8101	16500	16501	33000							
15	O2	Oxygen	24.7	29.7	29.7	34.7				3	10	11	30	31	92	93	280	281	860	861	2600	2601	7200	7201	15000	15001	30000	30001	37000	37001	55000			
16	NO	Nitric Oxide	24.7	29.7						3	10	11	30	31	92	93	280	281	860	861	2600	2601	7200	7201	15000	15001	30000							
17	HI	Hydrogen Iodide	24.7	29.7						3	5	6	15	16	48	47	141	142	432	433	1305	1306	3340	3341	6960	6961	13900							
18	F2	Fluorine	24.7	29.7						3	8	10	27	28	83	84	254	255	780	781	2358	2359	6700	6701	14900	14901	28000							
19	Cl2	Chlorine	24.7	29.7						3	6	7	19	20	57	58	173	174	531	532	1604	1605	4850	4851	10100	10101	20200							
22	H2S	Hydrogen Sulfide	24.7	29.7						3	8	9	25	26	76	77	232	233	713	714	2155	2156	5900	5901	12100	12101	24100							
23	H2Se	Hydrogen Selenide	24.7	29.7						3	7	8	22	23	66	67	202	203	620	621	1874	1875	4770	4771	10000	10001	20000							
25	CO2	Carbon Dioxide	24.7	29.7	29.7	29.7				3	7	8	22	23	69	70	209	210	642	643	1942	1943	5300	5301	11000	11001	22000	22001	28000	28001	39000			
27	N2O	Nitrous Oxide	24.7	29.7	29.7	29.7				3	7	8	21	22	65	66	200	201	611	612	1849	1850	5100	5101	10400	10401	21000	21001	25000	25001	37000			
28	CH4	Methane	24.7	24.7	29.7					3	8	9	23	24	71	72	215	216	660	661	2000	2001	5800	5801	12000	12001	24000	24001	46000					
29	NH3	Ammonia	24.7	24.7	29.7					3	8	9	24	25	73	74	223	224	685	686	2072	2073	6000	6001	12200	12201	25000	25001	46000					
31	PH3	Phosphine	19.7	24.7						3	7	8	22	23	67	68	205	206	629	630	1901	1902	5200	5201	10700	10701	21300							
32	SO2	Sulfur Dioxide	19.7	24.7						3	6	7	17	18	52	53	157	158	483	484	1459	1460	3800	3801	7920	7921	15800							
33	CH3F	Methyl Fluoride	24.7	29.7						3	7	8	22	23	67	68	204	205	625	626	1890	1891	5200	5201	10600	10601	21200							
34	COS	Carbonyl Sulfide	24.7	29.7						3	7	8	20	21	60	61	183	184	562	563	1700	1701	4500	4501	9400	9401	18300							
35	AsH3	Arsine	24.7	29.7						3	6	7	18	19	55	56	170	171	510	511	1550	1551	4000	4001	8500	8501	17000							
37	CICN	Cyanogen Chloride	14.7	21.7						3	5	6	15	16	46	47	142	143	435	436	1320	1321	3400	3401	7060	7061	14100							
38	C2H4	Ethylene	24.7	29.7						3	8	7	17	18	54	55	163	164	501	502	1516	1517	4400	4401	9300	9301	18200							
39	SiH4	Silane	24.7	29.7						3	6	7	18	19	56	57	170	171	523	524	1581	1582	4400	4401	9300	9301	18200							
42	C2H2	Acetylene	16.7	19.7						3	6	7	18	19	57	58	170	171	530	531	1600	1601	4400	4401	9300	9301	18200							
43	GeH4	Germane	24.7	29.7						3	6	7	17	18	53	54	161	162	495	496	1500	1501	4000	4001	8400	8401	16400							
46	COF2	Carbonyl Fluoride	19.7	19.7	21.7					3	5	6	17	18	53	54	160	161	500	501	1500	1501	4000	4001	8400	8401	16500	16501	21000					
48	BF3	Boron Trifluoride	19.7	24.7						3	5	6	16	17	50	51	150	151	457	458	1381	1382	3800	3801	7900	7901	15500							
49	CHF3	Fluorotrimethyl (Freon-23)	24.7	24.7	24.7	26.7				3	5	6	16	17	48	49	145	146	445	446	1344	1345	3600	3601	7600	7601	15000	15001	17000	17001	26000			
53	NF3	Nitrogen Trifluoride	24.7	29.7	24.7	26.7				3	5	6	15	16	46	47	140	141	430	431	1300	1301	3600	3601	7500	7501	15000	15001	17000	17001	26000			
54	C2H6	Ethane	17.7	29.7						3	5	6	16	17	50	51	153	154	469	470	1418	1419	4000	4001	8300	8301	16300							
58	B2H6	Diborane	19.7	19.7						3	4	5	12	13	38	39	116	117	358	359	1082	1083	3100	3101	6400	6401	12600							
60	COCl2	Phosgene	12.7	14.7						3	3	4	11	12	35	36	106	107	325	326	1000	1001	2520	2521	5250	5251	10500							
62	PF3	Phosphorus Trifluoride	19.7	24.7						3	4	5	14	15	42	43	129	130	400	401	1200	1201	3200	3201	6800	6801	13300							
63	CF4	Carbon Tetrafluoride (Freon-14)	24.7	24.7	24.7	26.7				3	4	5	13	14	40	41	121	122	372	373	1123	1124	3010	3011	6400	6401	12600	12601	17000	17001	22000			
67	SiH2Cl2	Dichlorosilane	14.7	19.7						3	3	4	10	11	29	30	89	90	273	274	824	825	2140	2141	4450	4451	8900							
69	C3H6-b)	Propylene	19.7	19.7						3	4	5	12	13	36	37	110	111	338	339	1022	1023	2800	2801	5900	5901	11700							
70	BCl3	Boron Trichloride	11.7	14.7						3	3	4	10	11	31	32	94	95	289	290	874	875	2230	2231	4650	4651	9300							
72	ClO3F	Perchloryl Fluoride	14.7	20.7						3	4	5	12	13	38	39	114	115	350	351	1060	1061	2860	2861	5800	5801	11500							
77	ClF3	Chlorine Trifluoride	14.7	20.7						3	4	5	11	12	35	36	107	108	327	328	1000	1001	2560	2561	5340	5341	10700							
85	C2H7N	Dimethylamine	9.7	14.7						3	3	4	11	12	34	35	101	102	310	311	960	961	2530	2531	5400	5401	10600							
88	SiF4	Silicon Tetrafluoride	19.7	24.7																														

# Appendix A: GF100 Series Gas Table

Table A-1B GF100 Series Gas Table - Codes 109-875, Bins SH40 to SH50

Gas Code	Gas Symbol	Gas Name	Min inlet pressure for vac. exhaust (PSIA)					SH40		SH41		SH42		SH43		SH44		SH45		SH46		SH47		SH48		SH49		SH50		
			SH40-SH47	SH48	SH49	SH50	Low	High	Low	High	Low	High	Low	High	Low	High	Low	High	Low	High	Low	High	Low	High	Low	High	Low	High	Low	High
109	C3H9N	Trimethylamine	6.7	8.7					3	8	9	25	26	76	79	240	241	720	721	1910	1911	4000	4001	8100						
110	SF6	Sulfur Hexafluoride	19.7	19.7	19.7	20.7			3	8	9	25	26	77	78	237	238	715	716	1900	1901	4000	4001	8000	8001	8200	8201	13400		
111	C4H10-d	Isobutane	19.7	19.7	19.7	20.7			3	7	8	23	24	70	71	216	217	653	654	1800	1801	3800	3801	7600	7601	8200	8201	13200		
117	C4H10-c	Butane	19.7	19.7	19.7	20.7			3	8	9	25	26	76	77	234	235	706	707	1910	1911	4000	4001	8100	8101	8200	8201	14100		
118	C2F6	Hexafluoroethane (Freon-116)	19.7	19.7					3	8	9	23	24	71	72	218	219	658	659	1750	1751	3700	3701	7400						
121	WF6	Tungsten Hexafluoride	9.7	11.7					3	5	6	16	17	50	51	150	151	460	461	1200	1201	2500	2501	5000						
128	C3F8	Perfluoropropane	19.7	19.7					3	5	6	16	17	50	51	154	155	465	466	1200	1201	2500	2501	5100						
129	C4F8	Octafluorocyclobutane	19.7	19.7					3	5	6	16	17	50	51	154	155	465	466	1170	1171	2430	2431	4900						
138	C3F6	Hexafluoropropylene	19.7	19.7					3	6	7	20	21	60	61	184	185	556	557	1470	1471	3050	3051	6110						
155	C2HF5	PENTAFLUOROETHANE (FREON)	19.7	19.7					3	8	9	25	26	77	78	235	236	711	712	1900	1901	4000	4001	8000						
160	CH2F2	Difluoromethane	24.7	29.7					3	6	7	19	20	57	58	174	175	533	534	1612	1613	4300	4301	9000	9001	18000				
185	C4H6S1	Methylsilane (MONO)	9.7	14.7					3	4	5	12	13	37	38	111	112	340	341	1050	1051	2800	2801	5900	5901	11600				
190	CH3/3SiH4	Trimethylsilane (TMS)	6.7						3	7	8	20	21	62	63	189	190	572	573	1530	1531	3200								
266	C5F8	Octafluorocyclopentene	9.7	14.7					3	5	6	14	15	44	45	134	135	406	407	1050	1051	2200	2201	4500						
270	C4F6	Hexafluoro-2-butyne	9.7						3	6	7	19	20	57	58	176	177	533	534	1400	1401	2900								
297	C4F6-q	Hexafluoro Butadiene-1-3	14.7	14.7					3	6	7	17	18	52	53	160	161	500	501	1270	1271	2640	2641	5270						
354	C5F8O	Epoxyperfluorocyclopentene	19.7	19.7					3	4	5	13	14	40	41	122	123	369	370	1000	1001	2100	2101	4200						
368	Si3H9N	Trisilylamine (TSA)	6.0	7.2					3	6	7	20	21	60	61	181	182	560	561	1410	1411	3000	3001	6000						
371	C4H11N	Dimethylethylamine	8.7	8.7					3	6	7	20	21	63	64	190	191	580	581	1530	1531	3200	3201	6500						
509	10%GeH4/H2	10%Germane/Hydrogen	20.7	20.7					3	9	10	28	29	86	87	260	261	800	801	2400	2401	7200	7201	15000	15001	30000				
516	10%PH3/H2	10%Phosphine/Hydrogen	14.7	14.7					3	9	10	28	29	90	91	275	276	813	814	2500	2501	7600	7601	15500	15501	31000				
527	10%PH3/N2	10%Phosphine/Nitrogen	19.7	24.7					3	9	10	30	31	91	92	271	272	850	851	2510	2511	7100	7101	14500	14501	29000				
528	4.5%PH3/N2	4.5%Phosphine/Nitrogen	20.7	29.7					3	10	11	30	31	94	95	280	281	880	881	2600	2601	7200	7201	15000	15001	30000				
536	20%O2/He	20%Oxygen/Helium	19.7	29.7					4	13	14	38	39	120	121	360	361	1102	1103	3331	3332	10000	10001	21000	21001	42000				
537	1%PH3/Ar	1%Phosphine/Argon	19.7	29.7					5	14	15	42	43	128	129	390	391	1200	1201	3600	3601	9800	9801	20000	20001	40000				
542	5%H2/N2	5%Hydrogen/Nitrogen	24.7	29.7					3	10	11	30	31	92	93	280	281	860	861	2600	2601	7400	7401	15100	15101	31000				
557	1%B2H6/H2	1%Diborane Hydrogen	24.7	29.7					3	10	11	30	31	91	92	270	271	850	851	2510	2511	7900	7901	16100	16101	33000				
563	1%PH3/H2	1%Phosphine/Hydrogen	19.7	19.7					3	10	11	30	31	90	91	273	274	850	851	2531	2532	7800	7801	16000	16001	32000				
595	3%B2H6/N2	3%Diborane/Nitrogen	20.7	29.7					3	9	10	29	30	90	91	270	271	850	851	2500	2501	7100	7101	14500	14501	29000				
597	3%H2/N2	3%Hydrogen/Nitrogen	24.7	29.7					3	10	11	30	31	92	93	280	281	860	861	2600	2601	7400	7401	15100	15101	30100				
603	30%He/O2	30%Helium/Oxygen	24.7	29.7					4	11	12	33	34	100	101	301	302	950	951	2800	2801	8100	8101	17000	17001	34000				
604	30%O2/He	30%Oxygen/Helium	19.7	29.7					4	12	13	37	38	113	114	345	346	1060	1061	3203	3204	9700	9701	20000	20001	40000				
606	4%He/H2	4%Hydrogen/Helium	19.7	19.7					5	14	15	41	42	126	127	400	401	1200	1201	3600	3601	11000	11001	23000	23001	46000				
607	4%He/N2	4%Hydrogen/Nitrogen	24.7	29.7					3	10	11	30	31	92	93	280	281	860	861	2600	2601	7400	7401	15100	15101	30100				
615	5%B2H6/Ar	5%Diborane/Argon	24.7						4	12	13	38	39	116	117	353	354	1084	1085	3278	3279	8900	8901	18200						
626	5%PH3/Ar	5%Phosphine/Argon	27.7	32.7					5	13	14	41	42	125	126	380	381	1170	1171	3600	3601	9500	9501	19400	19401	39000				
632	50%PH3/SiH4	50%Phosphine/Silane	16.7	24.7					3	6	7	20	21	62	63	190	191	580	581	1730	1731	4800	4801	10000	10001	20000				
649	10%O2/He	10%Oxygen/Helium	19.7	24.7					5	13	14	41	42	123	124	380	381	1150	1151	3500	3501	10500	10501	22000	22001	44000				
653	2%SiH4/N2	2%SiLANE/NITROGEN	19.7	24.7					3	10	11	30	31	93	94	280	281	870	871	2600	2601	7300	7301	15000	15001	30000				
654	5%B2H6/N2	5%Diborane/Nitrogen	24.7	29.7					3	9	10	28	29	86	87	262	263	804	805	2500	2501	7000	7001	14100	14101	28100				
662	8%B2H6/N2	8%Diborane/Nitrogen	24.7	29.7					3	10	11	30	31	93	94	280	281	870	871	2600	2601	7300	7301	15000	15001	30000				
674	10%PH3/He	10%Phosphine/Helium	14.7	19.7					4	13	14	40	41	120	121	370	371	1100	1101	3400	3401	10000	10001	21000	21001	43000				
676	7.5%PH3/SiH4	7.5%Phosphine/Silane	14.7	14.7					3	6	7	19	20	58	59	175	176	540	541	1510	1511	4500	4501	9400	9401	18400				
683	5%PH3/He	5%Phosphine/Helium	12.7	14.7					4	13	14	41	42	125	126	380	381	1150	1151	3500	3501	10500	10501	22000	22001	44000				
695	2%B2H6/N2	2%Diborane/Nitrogen	24.7	29.7					3	10	11	30	31	93	94	280	281	870	871	2600	2601	7200	7201	15000	15001	30000				
698	10%GeH4/Ar	10%Germane/Argon	24.7	29.7					4	12	13	38	39	114	115	350	351	1070	1071	3300	3301	8700	8701	18000	18001	36000				
700	4%He/Ar	4%Hydrogen/Argon	24.7	29.7					5	14	15	42	43	130	131	390	391	1200	1201	3700	3701	9800	9801	20000	20001	40000				
701	10%B2H6/H2	10%Diborane/Hydrogen	14.7	14.7					3	8	9	26	27	81	82	241	242	760	761	2300	2301	7000	7001	14200	14201	29000				
762	5%He/H2	5%Hydrogen/Helium	19.7	19.7					5	14	15	41	42	125	126	400	401	1200	1201	3600	3601	11000	11001	23000	23001	46000				
766	5%B2H6/He	5%Diborane/He	14.7	16.7					4	12	13	38	39	115	116	350	351	1100	1101	3300	3301	10000	10001	21000	21001	42000				
780	5%SiH4/He	5%Silane/He	14.7	16.7					4	13	14	40	41	122	123	380	381	1140	1141	3500	3501	10500	10501	22000	22001	44000				
805	1%B2H6/Ar	1%Diborane/Argon	14.7	16.7					5	14	15	42	43	130	131	390	391	1200	1201	3600	3601	9700	9701	20000	20001	40000				
8																														

### GF100 Series Patents

The GF100 Series may be protected by the following US patents and their international filings.

*Table B-1 GF100 Series Patents*

<b>Patent/Pub. No.</b>	<b>Title</b>
6343617	System and method of operation of a digital mass flow controller
6389364	System and method for a digital mass flow controller
6425281	Pressure insensitive gas control system
6445980	System and method for a variable gain proportional-integral (PI) controller
6539792	Method and apparatus for balancing resistance
6640822	System and method of operation of a digital mass flow controller
6681787	System and method of operation of a digital mass flow controller
6714878	System and method for a digital mass flow controller
6752166	Method and apparatus for providing a determined ratio of process fluids
6826953	Flow sensor
6845659	Variable resistance sensor with common reference leg
6910381	System and method of operation of an embedded system for a digital capacitance diaphragm gauge
6941965	Method and apparatus for providing a determined ratio of process fluids
6962164	System and method for a mass flow controller
7043374	Flow sensor signal conversion
7073392	Methods and apparatus for pressure compensation in a mass flow controller
7082824	Variable resistance sensor with common reference leg
7113895	System and method for filtering output in mass flow controllers and mass flow meters
7114511	System and method for a mass flow controller
7133785	Valve control system and method
7143774	Method and apparatus for providing a determined ratio of process fluids
7150201	System and method for measuring flow
7216019	Method and system for a mass flow controller with reduced pressure sensitivity
7231931	System and method for a mass flow controller
7243035	System and method for mass flow detection device calibration
7272512	Flow sensor signal conversion
7273063	Methods and apparatus for pressure compensation in a mass flow controller
7287434	System and method for measuring flow
7360551	Method and apparatus for providing a determined ratio of process fluids
7363182	System and method for mass flow detection device calibration
7380564	System and method for a mass flow controller
7409871	Mass flow meter or controller with inclination sensor
7412986	Method and system for flow measurement and validation of a mass flow controller
7424894	Method and apparatus for providing a determined ratio of process fluids
7434477	Methods and apparatus for pressure compensation in a mass flow controller

## LIMITED WARRANTY

Visit [www.BrooksInstrument.com](http://www.BrooksInstrument.com) for the terms and conditions of our limited warranty.

## BROOKS SERVICE AND SUPPORT

Brooks is committed to assuring all of our customers receive the ideal flow solution for their application, along with outstanding service and support to back it up. We operate first class repair facilities located around the world to provide rapid response and support. Each location utilizes primary standard calibration equipment to ensure accuracy and reliability for repairs and recalibration and is certified by our local Weights and Measures Authorities and traceable to the relevant International Standards.

Visit [www.BrooksInstrument.com](http://www.BrooksInstrument.com) to locate the service location nearest to you.

## START-UP SERVICE AND IN-SITU CALIBRATION

Brooks Instrument can provide start-up service prior to operation when required. For some process applications, where ISO-9001 Quality Certification is important, it is mandatory to verify and/or (re)calibrate the products periodically. In many cases this service can be provided under in-situ conditions, and the results will be traceable to the relevant international quality standards.

## CUSTOMER SEMINARS AND TRAINING

Brooks Instrument can provide customer seminars and dedicated training to engineers, end users and maintenance persons.

*Please contact your nearest sales representative for more details.*

Due to Brooks Instrument's commitment to continuous improvement of our products, all specifications are subject to change without notice.

## TRADEMARKS

Brooks and MultiFlo are trademarks of Brooks Instrument, LLC  
All other trademarks are the property of their respective owners.



X-TMF-GF100-Series-eng/541B137AAG/2021-06

## Global Headquarters

**Brooks Instrument**  
407 West Vine Street  
Hatfield, PA  
19440-0903 USA

Toll-Free (USA): 888-554-FLOW  
T: 215-362-3500

[BrooksAM@BrooksInstrument.com](mailto:BrooksAM@BrooksInstrument.com)

A list of all Brooks Instrument locations and contact details can be found at [www.BrooksInstrument.com](http://www.BrooksInstrument.com)

©Copyright 2021 Brooks Instrument, LLC All rights reserved. Printed in U.S.A.

**BROOKS**<sup>®</sup>  
INSTRUMENT  
*Beyond Measure*