

# EtherNet/IP™ Supplemental Manual

## **SLA5800 & SLAMf Series Digital Mass Flow Controllers & Meters** (Product revision 4.5 and greater)

**BROOKS®**  
INSTRUMENT

*Beyond Measure*

# ESSENTIAL INSTRUCTIONS

## Read this page before proceeding

Brooks Instrument designs, manufactures and tests its products to meet many national and international standards. Because these instruments are sophisticated technical products, you must properly install, use and maintain them to ensure they continue to operate within their normal specifications. The following instructions must be adhered to and integrated into your safety program when installing, using and maintaining Brooks Products.

- Read all instructions prior to installing, operating and servicing the product. If this instruction manual is not the correct manual, please see back cover for local sales office contact information. Save this instruction manual for future reference
- If you do not understand any of the instructions, contact your BrooksInstrument representative for clarification
- Follow all warnings, cautions and instructions marked on and supplied with the product
- Inform and educate your personnel in the proper installation, operation and maintenance of the product
- Install your equipment as specified in the installation instructions of the appropriate instruction manual and per applicable local and national codes. Connect all products to the proper electrical and pressure sources.
- To ensure proper performance, use qualified personnel to install, operate, update, program and maintain the product
- When replacement parts are required, ensure that qualified people use replacement parts specified by Brooks Instrument.
- Unauthorized parts and procedures can affect the product's performance and place the safe operation of your process at risk. Look-alike substitutions may result in fire, electrical hazards or improper operation.
- Ensure that all equipment doors are closed and protective covers are in place, except when maintenance is being performed by qualified persons, to prevent electrical shock and personal injury.

## ESD (Electrostatic Discharge)

### ⚠ CAUTION

This instrument contains electronic components that are susceptible to damage by electricity. Proper handling procedures must be observed during the removal, installation, or other handling of internal circuit boards or devices

#### Handling Procedure:

1. Power to the unit must be removed
2. Personnel must be grounded, via a wrist strap or other safe, suitable means before any printed circuit card or other internal device is installed, removed or adjusted.
3. Printed circuit cards must be transported in a conductive container. Boards must not be removed from protective enclosure until immediately before installation. Removed boards must immediately be placed in protective container for transport, storage or return to factory.

#### Comments:

This instrument is not unique in its content of ESD (electrostatic discharge) sensitive components. Most modern electronic designs contain components that utilize metal oxide technology (NMOS, SMOS, etc.). Experience has proven that even small amounts of static electricity can damage or destroy these devices. Damaged components, even though they appear to function properly, exhibit early failure.

## Contents

<b>Section 1: General Information</b> .....	1
<b>Section 2: Definition of Terms</b> .....	2
<b>Section 3: Before Starting</b>	
Background & Assumptions .....	3
Compliance .....	3
Notations .....	3
Numbers .....	4
EPATHS .....	4
<b>Section 4: Quick Start</b>	
Physical Interfaces .....	5
Communications I/O SLAMf .....	6
Power Supply & Communications SLA5800 .....	8
Communications Notes: SLA5800 & SLAMf .....	11
MOD LED .....	11
NET LED .....	12
TC/IP Network Configuration .....	12
Class 1 Connection (Cyclic I/O) .....	13
Class 3 Connection (Acyclic I/O) .....	13
<b>Section 5: Configuration</b>	
Commonly Configured Attributes .....	14
Data Units .....	15
Safe Modes .....	15
Valve Safe Mode .....	16
Process Gas Page Configuration .....	17
Class 1 Connections .....	18
Data Assemblies .....	19
Configuration Assembly .....	19
Output Assemblies .....	23
Input Assemblies .....	24
<b>Section 6: Detailed Configuration</b>	
Overview .....	29
Identity Object [0x01] .....	30
Attributes .....	30
Services .....	32
Assembly Object [0x04] .....	33
Attributes .....	33
Services .....	33
Device Manager Object [0x64] .....	34
Attributes .....	34
Services .....	36
Flow Meter Object [0xA9] .....	37
Attributes .....	37
Services .....	43
Valve Driver Object [0x96] .....	44
Attributes .....	44
Services .....	47
Flow Controller Object [0x9E] .....	47
Attributes .....	47
Services .....	49
Process Gas Object [0x66] .....	49
Attributes .....	49
Services .....	50

## Contents

Temperature Meter Object [0xA4].....	50
Attributes .....	51
Services.....	51
Status Object [0xB8].....	51
Attributes .....	52
Services.....	54
<b>Section 7: Status</b>	
Device Status {184-1-6}.....	55
Bit 0: Device is Executing [Device_Status_Dev_Exec] .....	55
Bit 1: Flow Reading Valid [Device_Status_Flow_Valid].....	56
Bit 2: Temperature Reading Valid [Device_Status_Temp_Valid] .....	56
Bit 3: Device is Zeroing [Device_Status_Dev_Zeroing].....	56
Bit 4: Zero Recommended [Device_Status_Zero_Recommend] .....	57
Bit 5: Zero Operation Inhibit [Device_Status_Zero_Op_Inhibit] .....	58
Bit 6: Valve Override [Device_Status_Valve_Override].....	58
Bit 7: Control Override [Device_Status_Ctrl_Override] .....	59
Bit 8: Device Error [Device_Status_Dev_Error].....	59
Bit 9: Device Alarm [Device_Status_Dev_Alarm].....	59
Bit 10: Device Warning [Device_Status_Dev_Warning].....	59
Bit 11: Zero Button Disabled [Device_Status_Zero_Btn_Disabled].....	60
Bit 12: Control Ramping [Device_Status_Ctrl_Ramping].....	60
Warnings {184-1-5}.....	61
Bit 0: Low Flow Warning.....	61
Bit 1: High Flow Warning.....	61
Bit 3: Choked Flow Warning.....	62
Bit 4: Excessive Zero Drift Warning.....	63
Bit 5: Bad Zero Warning .....	64
Bit 8: Valve High Warning.....	65
Bit 9: Valve Low Warning.....	65
Bit 10: Valve Control Warning.....	65
Bit 11: Setpoint Deviation .....	66
Bit 13: Setpoint Over range .....	67
Bit 14: Setpoint Limited .....	68
Bit 17: Calibration Due .....	69
Bit 18: Totalizer Overflow.....	69
Bit 19: Overhaul Due.....	69
Bit 24: High Temperature Warning .....	70
Bit 25: Low Temperature .....	70
Bit 26: Supply Volts High.....	70
Bit 27: Supply Volts Low.....	71
Alarms {184-1-4}.....	72
Bit 0: Low Flow Alarm.....	72
Bit 1: High Flow Alarm.....	72
Bit 2: No Flow Alarm.....	73
Bit 3: Choked Flow Alarm.....	74
Bit 15: Invalid Process Gas Page Selected.....	75
Bit 23: Using Backup NV Memory .....	75
Bit 24: Temperature Sensor Fail.....	75
Errors {184-1-3}.....	76
Bit 2: Back Streaming Error.....	76
Bit 18: Internal Communication Error .....	76
Bit 23: NV Memory Fail .....	76
Typical Status High/Low Processing .....	77

## Contents

<b>Section 8: Troubleshooting</b> .....	78
<b>Section 9: Appendix</b>	
Appendix A - Ethernet/IP Connections .....	79
Appendix B - Data Type Definitions .....	80
Appendix C - Data Units .....	81
Appendix D - Service Summary Details .....	83
<b>Section 10: Glossary</b>	
Assembly .....	84
Attribute .....	84
Class .....	84
Connection .....	84
Device Profile .....	84
EDS .....	84
EPATH .....	84
Expected Packet Rate (EPR) .....	85
Class 3 Connection .....	85
Class 1 Connection .....	85
Instance .....	85
Safe State (Safe Mode) .....	85
Service .....	85

## Contents

### Table Number

2-1	Definition.....	2
4-1	Pin Labeling of M12 Female Connectors (2 per device).....	6
4-2	Pin Labeling of M12 Male Device and Female Mating Cable Connector (Figure 4-8) SLAMf.....	7
4-3	Pin Labeling of M8 Male Device and Female Mating Cable Connector SLA5800.....	8
4-4	Wire Labeling of M8 Female Mating Cable Connector (See Table 4-2 & Figure 4-5 for mating pins on the device).....	9
4-5	M8 Female Mating Cable Part Numbers .....	9
4-6	M12 Cable Connector Pinout.....	10
4-7	M12 Female Mating Cable Part Numbers .....	10
4-8	MOD LED Indicator Definitions.....	11
4-9	NET LED Indicator Definitions .....	11
4-10	MFC Exclusive Owner Connection Configuration.....	13
4-11	MFM Input Only Connection Configuration.....	13
5-1	Commonly Configured Attributes/Parameters .....	15
5-2	Configurable Data Units Attributes.....	15
5-3	Safe State .....	16
5-4	MFC Class 1 Connection Configurations.....	18
5-5	MFM Class 1 Connection Configurations .....	18
5-6	MFC Configuration Assembly Definition .....	20
5-7	MFM Configuration Assembly Definition.....	22
5-8	Process Control 1 Assembly.....	23
5-9	Detailed Process Monitoring Assembly .....	24
5-10	Totalizers and Other Process Conditions Assembly .....	25
5-11	Flow and Detailed Device Status Assembly .....	26
5-12	Detailed Process Monitoring, Totalizers, and Other Process Conditions.....	27
5-13	Detailed Process Monitoring, Totalizers, and Other Process Conditions.....	28
6-1	Accessible Classes.....	29
6-2	Common Services for all Objects .....	30
6-3	Identity Instance Attributes.....	30
6-4	Identity Object Status.....	31
6-5	Identity Object Reset Service Arguments .....	32
6-6	Identity Object Reset Service Response .....	32
6-7	Assembly Object Instance Attributes .....	33
6-8	Device Manager Instance Attributes .....	34
6-9	Device Manager Services.....	36
6-10	Start Service Parameters.....	36
6-11	Start Service Return .....	36
6-12	Stop Service Parameters.....	37
6-13	Start Service Return .....	37
6-14	Flow Meter Instance Attributes .....	37
6-15	Flow Meter Instance Services.....	43
6-16	Get Zero History Service Arguments .....	44
6-17	Get Zero History Service Response .....	44
6-18	Value Driver Object Instance Attributes .....	44
6-19	Override.....	46
6-20	Safe State .....	47
6-21	Flow Controller Object Instance Attributes.....	47

## Contents

### **Table** **Number**

6-22	Setpoint Limiting Actions.....	48
6-23	Setpoint Limiting Actions.....	49
6-24	Process Gas Instance 0 Attributes.....	49
6-25	Process Gas Instance 1..n Attributes.....	50
6-26	Temperature Meter Object Instance 1 Attributes .....	51
6-27	Status Object Instance 1..n Attributes.....	52
6-28	Active Error Bit Definitions .....	52
6-29	Active Alarms Bit Definitions .....	52
6-30	Active Warnings Bit Definitions .....	53
6-31	Device Status Bit Definitions.....	54
9-1	Data Types.....	80
9-2	Volumetric Flow Units Table.....	81
9-3	Actuator Units .....	82
9-4	Temperature Units .....	82
9-5	Volume Units Table (Used by Totalizers) .....	82
9-6	Get Attribute Single Service Parameters .....	83
9-7	Success Response Data .....	83
9-8	Set Attribute Single Service Parameters.....	83
9-9	Success Response Data .....	83

### **Figure** **Number**

4-1	Pin Labeling of M12 Female Connectors (2 per device).....	6
4-2	Layout Under Top Cover Insert SLAMf Hazardous Area Device .....	6
4-3	SLAMf Hazardous Area Device side view with M12 Power connector .....	7
4-4	EtherNet/IP Top Cover.....	8
4-5	M8 Male Device Connector Pin Layout, Pin Side View SLA5800 .....	8
4-6	M8 Female Mating Cable.....	9
4-7	M8 Female Mating Cable Connector .....	9
4-8	M12 Power Cable .....	10
4-9	M12 Cable Female Connector End view .....	10

## Section 1: General Information

Many applications of Flow Controllers/Meters are moving to increase the use of automation. Automation comes in many forms: PLC's (Programmable Logic Controllers, like those from Allen/Bradley, DCS's (Distributed Control Systems, such as Emerson's DeltaV), PC-based solutions (National Instruments LabVIEW™), and Ethernet based field buses. Digital communications from these varied systems and the devices they measure and control, are a very effective means of not only accomplishing more effective and rapid system integration, but also providing greatly improved system diagnostics and maintainability. EtherNet/IP™ is an Ethernet-based communications system for industrial automation applications built upon the IEEE 802.3 standards and TCP/IP communications standards. EtherNet/IP™ utilizes the Common Industrial Protocol (CIP™) as a top layer (application layer) of the TCP/IP protocol stack. This solution leverages the power of the internet and enterprise connectivity, combined with the functionality and comprehensive suite of messages and services for manufacturing automation applications. The EtherNet/IP™ interface is now available on SLA Series.



## Section 2 Definition of Terms

Table 2-1 Definitions

Abbreviation	Description
Byte	A Byte refers to 8 consecutive bits.
CRC	Checksum (Cyclic Redundancy Check)
EIP	Ethernet/IP
EDS	Electronic Data Sheet
EtherNet/IP™	Ethernet - Industrial Protocol
GSDML	XML Format of General Station Description file
LSB	Least Significant Bit or Least Significant Byte
MAC	Media Access Control is responsible for address checking and is most often done in the hardware of a NIC.
Master	A Master is a unit which controls the Slaves, feeding them commands and receiving status reports in exchange.
MFC/MFM	Mass Flow Controller / Mass Flow Meter
MSB	Most Significant Bit or Most Significant Byte
MTU	Maximum Transmission Unit. The maximum payload that a standard Ethernet Frame can hold. The MTU is set at 1500 bytes (Not considering the Header and Checksum).
NIC	Network Interface Controller. A hardware component that connects a computer to a network.
NV	Non-Volatile
OSI Model	A standardized representation for how a communication system can be organized. (e.g., a protocol stack) The model is divided into layers, each responsible for a part of the communication.
RO	Read Only
RT	Real-time. A system that adheres to strict timing demands.
RW	Read / Write
Slave	A Slave is a unit (node) on the network (e.g., an MFC). The Slave is connected to a Master.
Stack	A synonym for the implementation of the layers of a protocol.
TCP/IP	Transport Control Protocol/Internet Protocol
Topology	The way a network (Master & Slaves) is inter-connected. The overall layout. (e.g., Star, Tree, Line Topology)
WO	Write Only
DLR	Device Level Ring

## Section 3 Before Starting

### Background & Assumptions

This manual is a supplement to the SLA Series 5800 and MF Mass Flow Controller Installation and Operation Manuals. It is recommended that the owner read the Operations Manual first before continuing with this supplement.

This manual is valid for revision 4.5 and greater of the product. To verify the revision of the product, query the Major and Minor Revision of the Identity object, view the "Protocol Settings" window in the Brooks

Expert Support Tool (BEST) software, or view the "Device Info" screen in the embedded web interface. If the revision is lower than 4.5, please contact Brooks Technical Services for assistance in upgrading the device firmware.

This manual assumes a basic knowledge and understanding of the EtherNet/IP™ protocol, its topology and its method of logically accessing the data or parameters contained within a device. This manual also assumes basic knowledge and understanding regarding the operation of Mass Flow Controllers or Mass Flow Meters. This manual is not intended to be a replacement to the ODVA specification, which is still the authoritative definition and description of EtherNet/IP™ communications. It is recommended, but not required for the purposes of this manual, that the user obtain a copy of the EtherNet/IP™ specification from ODVA (<http://www.odva.org/>).

This manual does not make any assumptions about any manufacturer of equipment or custom software used by the user to communicate with the Brooks Instrument device but assumes the user has thorough understanding of such equipment and any configuration software.

### Compliance

The SLA Series Mass Flow Controller (MFC) or Mass Flow Meter (MFM) conforms to the ODVA specified Device Profile for a Generic Device.

### Notations

This section details notations and conventions used throughout the manual. It is recommended that the reader become very familiar with these conventions.

Hypertext links are used in the manual to assist in navigating. A glossary is provided for reference in Section: 10 Glossary to aid in reviewing and/or to define any unfamiliar terms.

## Numbers

Numeric values used throughout this manual will be clearly denoted as to the base numeric system it represents. All hexadecimal numbers (base 16) will be prefixed with a 0x, like 0xA4. All binary numbers (base 2) will be suffixed with a b, like 1001b. All other numbers not annotated this way will be assumed decimal (base 10).

## EPATHS

EPATH's will be denoted within brackets [] or braces {}, like [0x31, 1, 3], {0x31-1-3} which represents, left to right, the Class ID (hexadecimal or decimal), Instance ID (decimal), and Attribute ID (decimal)

## Section 4 Quick Start

This section assumes that the owner of the Digital Series device has a fully operational and trouble-free communications network with appropriate power supplies. This section also assumes that a master device or application is connected to the network, capable of Class 1 and Class 3 message communications. Both types of data communication modes are supported by the SLA Series EtherNet/IPTM device.

### Physical Interfaces

The available physical interfaces on the Ethernet/IPTM SLAMF Device are listed below:

- In and Out M12 threaded female connectors labeled “1” and “2” for Ethernet/IPTM Communications (Figure 4-1).
- 2.5 mm female jack for RS485 diagnostic port, which is located either under the top cover (SLAMf IP-66 only versions) or under the access screw on the inlet side of the device, just above the M12 power connection (shown in Figure 4-3).
- 4 pin M12 threaded Male (Euro Lock) Connector for power labeled “PWR” (figure 4-3).
- Note that earlier versions of the SLAMf IP66 (only) devices were equipped with M8 power connectors. Diagrams for these connectors can be found in the SLAMf Series Elastomer Sealed, Thermal Mass Flow Meters and Controllers Instruction and Operations Manual (IOM).

The available physical interfaces on the EtherNet/IPTM SLA5800 device are listed below (Figure 4-4):

- 5 pin M8 threaded male connector for power labeled "PWR".
- In and Out ports with RJ-45 connectors labeled “1” and “2” for Ethernet/IPTM Communications.
- 2.5 mm female jack for RS485 diagnostic port labeled ‘DIAG,’ refer to the SLA Series Installation and Operation Manual for more details.

## Section 4 Quick Start

### Communications I/O SLAMF

Digital I/O needs to be supplied via the M12 Connector, see Table 4-1.

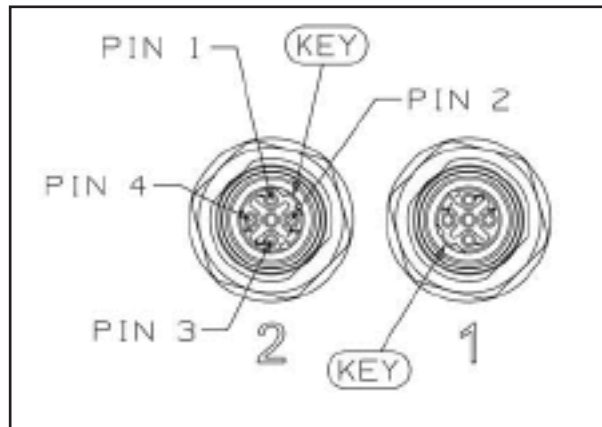

Figure 4-1 Pin Labeling of M12 Female Connectors (2 per device)

Connector	Function
1	TD+
2	RD+
3	TD-
4	RD-

Table 4-1 Pin function of M12 Female Connectors (2 per device)

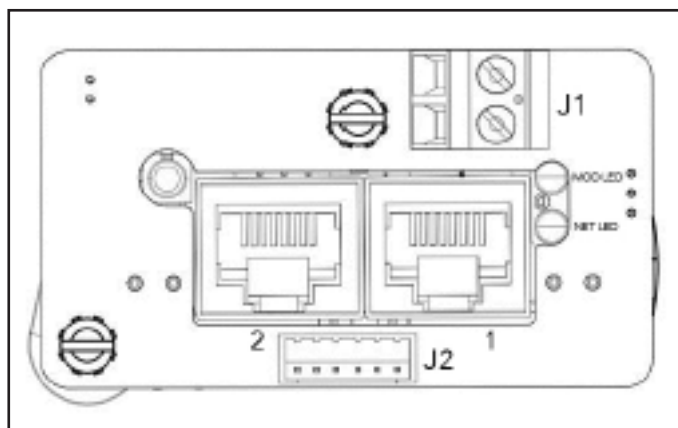

Figure 4-2 SLAMf Hazardous Area Device Layout Under Top Cover

## Section 4 Quick Start

### Power Supply SLAMF

Power needs to be supplied via the M12 connector.

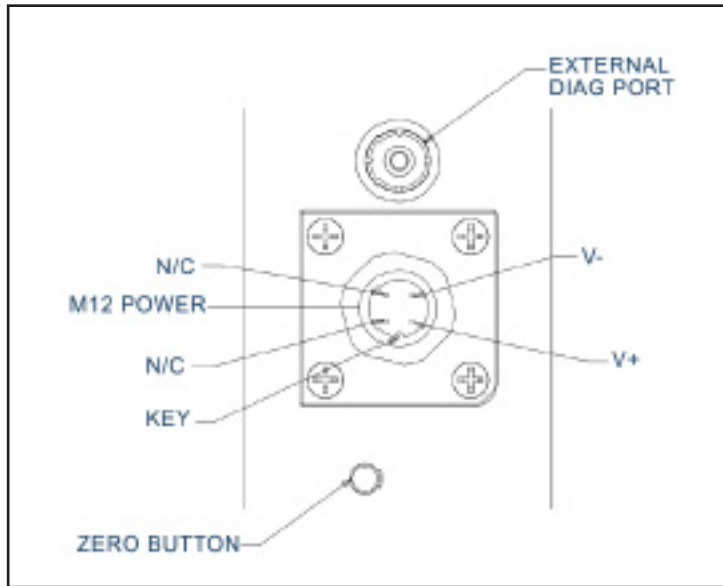

Figure 4-3 SLAMf Hazardous Area device side view with M12 Power connector

Table 4-2: Pin Labeling of M12 Male Device and Female Mating Cable Connector SLAMf

Pin Label	Function at Remote Connector
V+	Positive Power Supply Voltage
V-	Power Supply Ground
N/C	Not Connected

## Section 4 Quick Start

### Power Supply & Communications SLA5800

Power needs to be supplied via the M8 connector. See Table 4-3.

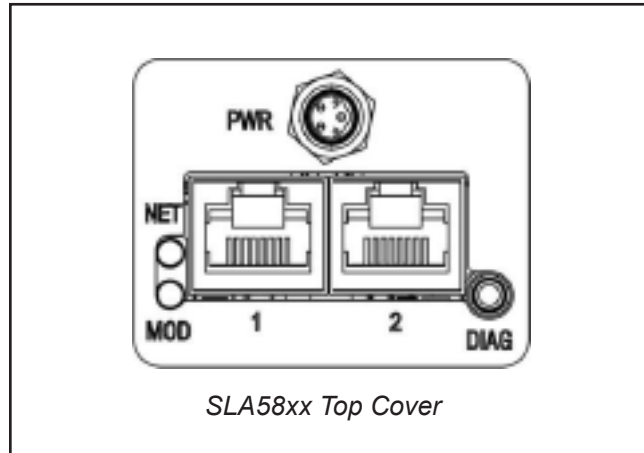

Figure 4-4: EtherNet/IP Top Cover

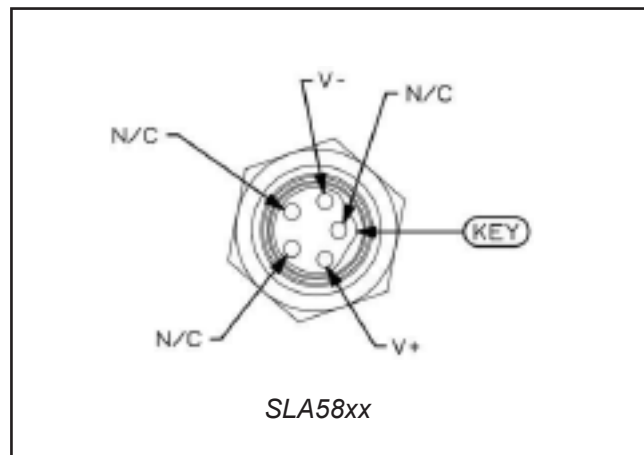

Figure 4-5: M8 Male Device Connector Pin Layout, Pin Side View SLA5800

Table 4-3: Pin Labeling of M8 Male Device and Female Mating Cable Connector SLA5800

Pin Label	Function at Remote Connector
V+	Positive Power Supply Voltage
V-	Power Supply Ground
N/C	Not Connected

## Section 4 Quick Start

M8 & M12 mating cable details.

Mating Cables can be purchased as a second line item as below.

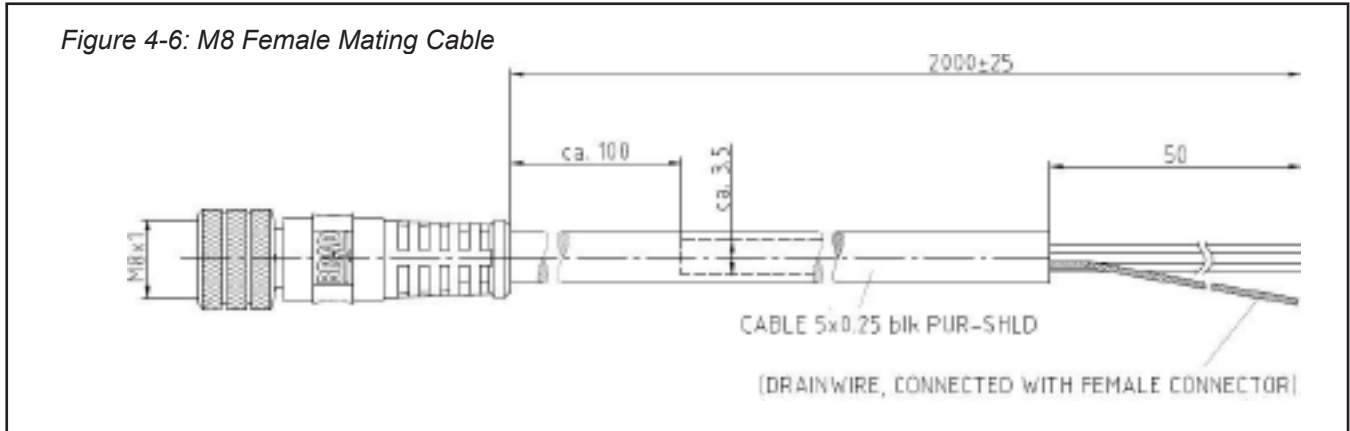

Figure 4-7: M8 Female Mating Cable Connector Pin

### MATING SIDE FEMALE CABLE CONNECTOR

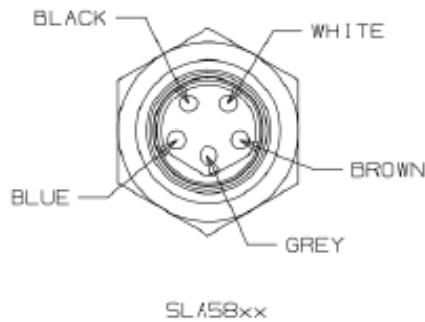

Table 4-4: Wire Labeling of M8 Female Mating Cable Connector

Wire Color	Wire Label	Function at Remote Connector
Blue	V	Power Supply Ground
Brown	V+	Positive Power Supply Voltage
Black	N/C	Not Connected
White	N/C	Not Connected
Grey	N/C	Not Connected

Table 4-5: M8 Female Mating Cable Part Numbers

Supplier	Part Number	Description
Brooks Instrument	124X049AAA	M8 Mating Cable 2m
	124X050AAA	M8 Mating Cable 5m
	124Z170AAA	ECAT to DB15 Male



Section 4 Quick Start

Figure 4-8 M12 Power Cable

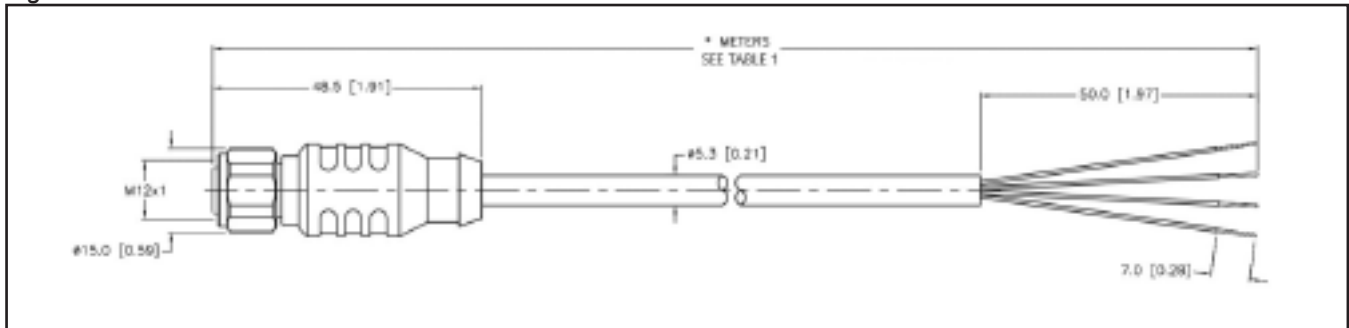

Figure 4-9 M12 Cable Female Connector End view

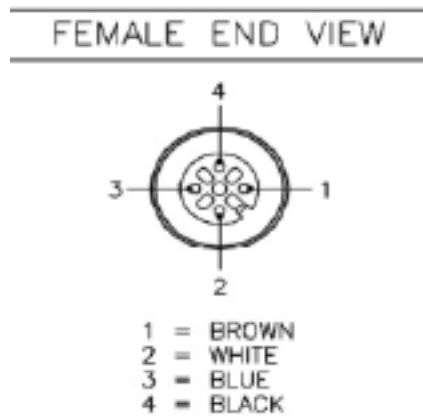

Table 4-6 M12 Cable Connector Pinout

Wire Color	Wire Label	Function
Brown	N/C	Not Connected
White	V+	Positive Power Supply Voltage
Blue	V-	Power Supply Ground
Black	N/C	Not Connected

Table 4-7: M12 Female Mating Cable Part Numbers

Supplier	Part Number	Description
Brooks Instrument	124X309AAA	M12 Power, C1D2, 2m
	124X310AAA	M12 Power, C1D2, 3m
	124Z311AAA	M12 Power, C1D2, 8m
	124Z312AAA	M12 Power, C1D2, 15m

## Section 4 Quick Start

**COMMUNICATIONS NOTES: SLA5800 & SLAMf**

As noted in the Physical Interface Sections, above, each SLAMf EtherNet/IPTM device has (2) M12 4 Pole, Female “D” Coded Connectors (Figure 4-1) labeled 1 and 2. And each SLA5800 Series EtherNet/IPTM device has (2) RJ-45 Ethernet Connection ports labeled 1 and 2 (Figure 4-4).

Network connections can be made to either or both ports, depending on the network topology. The SLA5800/Mf Series EtherNet/IPTM device will support star, linear and DLR (Device Level Ring) topologies. Click the following reference for more detailed information on EIP topologies and their implementation

[https://literature.rockwellautomation.com/idc/groups/literature/documents/at/enet-at007\\_-en-p.pdf](https://literature.rockwellautomation.com/idc/groups/literature/documents/at/enet-at007_-en-p.pdf)

The SLA5800/Mf Series EtherNet/IPTM device supports auto-negotiation of the communications link. Both ports support data rates of 10/100 Mbps and Half/Full duplex communications. The device may be directly connected to the Ethernet NIC on a desktop or laptop PC for configuration and commissioning activities.

**MOD LED**

*Table 4-8: MOD LED Indicator Definitions*

Indicator State	Summary	Requirement
Off	No power	No power is supplied to the device.
Solid Green	Device Operational	Device is operating correctly.
Flashing Green	Standby	Device has not been configured.
Flashing Red	Major Recoverable Fault	The device has detected a Major Recoverable Fault (Alarm) The alarm must be enabled for the LED to flash red.
Solid Red	Major Unrecoverable Fault	The device has detected a Major Unrecoverable fault (Error).
Flashing Green / Red	Self-test	The device is performing its power-up testing.

## Section 4 Quick Start

## NET LED

Table 4-9: NET LED Indicator Definitions

Indicator State	Summary	Requirement
Off	Not powered, or no IP address.	The device is powered off or is powered on but with no IP address configured.
Flashing Green	No connections	An IP address is configured, but no CIP connections are established with the device.
Steady Green	Connected	An IP address is configured, at least one CIP connection (any transport class) is established with the device.
Flashing Red	Connection Timeout	An IP address is configured, and an Exclusive Owner connection has timed out. The NET indicator will return to steady green when the Exclusive Owner connection is reestablished.
Steady Red	Duplicate IP	The device has detected that its IP address is already in use.
Flashing Green / Red	Self-test	The device is performing its power-up testing.

## TCP/IP Network Configuration

The TCP/IP network settings can be configured using a web browser interface or through a variety of network utilities. By default, SLA Series EtherNet/IPTM MFC is shipped with DHCP enabled. If no DHCP server is available on the network, the device defaults to the following TCP/IP connections settings:

IP Address: 192.168.1.100  
NET Mask: 255.255.255.0  
Gateway Address: 0.0.0.0  
DNS1: 0.0.0.0  
DNS2: 0.0.0.0

To configure using a web browser, connect the device to the network that is configured with the same subnet as the device (192.168.1.xxx). Open the web browser and enter the IP address of the device as the URL.

The Web Interface opens in read-only mode. To change the configuration, click the Login Tab. From the pulldown, select Configure or Control. The default password for Configure is 'configure'. The default password for Control is 'control'.

Click the Network Tab. By default, DHCP is selected. To manually configure the network settings, select the 'Store Value' radio button. The network configuration fields will become active. Click 'Submit' after setting the network configuration.

NOTE: Once the settings have been changed, the TCP/IP address will need to be reentered in the URL field of the browser to reconnect with the device and confirm the network settings.

## Section 4 Quick Start

**Class 1 Connection (Cyclic I/O)**

The following connection configuration can be used to create a Class 1 connection (also known as I/O Connection or Cyclic Data Connection). See Section 5 for more information on other Class 1 connection configurations.

(See Appendix A for details on Class 1 Connection Types)

**MFC**

Table 4-10: MFC Exclusive Owner Connection Configuration

Output <sup>3</sup> Assembly ID	101
Output Assembly Size	(See Table 5-4 in Section 5 for Assembly 101 Size)
Output Assembly RPI	>= 50 msec
Input <sup>3</sup> Assembly	201
Input Assembly Size	(See Table 5-4 in Section 5 for Assembly 201 Size)
Input Assembly RPI	>= 50 msec
Configuration Assembly <sup>1</sup>	100
Configuration Assembly Size <sup>2</sup>	(See Table 5-4 in Section 5 for Configuration Assembly 100 Size)

1. If no configuration data is to be transferred to the device, set the configuration assembly ID to 0 with a data length of 0.

2. All field values in the configuration assembly data must have valid values or the assembly data will be rejected along with the connection open request.

3. The terms Input/Output are relative to the Master/Controller

**MFM**

Table 4-11: MFM Input Only Connection Configuration

Output <sup>3</sup> Assembly ID	102
Output Assembly Size	(See Table 5-5 in Section 5 for Assembly 102 Size)
Output Assembly RPI	>= 50 msec
Input Assembly	203
Input Assembly Size	(See Table 5-5 in Section 5 for Assembly 203 Size)
Input Assembly RPI	>= 50 msec
Configuration Assembly <sup>1</sup>	100
Configuration Assembly Size <sup>2</sup>	(See Table 5-5 in Section 5 for Configuration Assembly 100 Size)

1. If no configuration data is to be transferred to the device, set the configuration assembly ID to 0 with a data length of 0.

2. All field values in the configuration assembly data must have valid values or the assembly data will be rejected along with the connection open request.

3. The terms Input/Output are relative to the Master/Controller

**Class 3 Connection (Acyclic I/O)**

The SLA Series EtherNet/IP™ devices support Class 3 connections. See Section 6 for details on supported objects and attribute definitions in the device.

## Section 5 Configuration

### Section 5: Configuration

#### Commonly Configured Attributes

EtherNet/IP™ provide several ways to configure a device. As noted in the previous sections, a configuration assembly can be used when establishing Class 1 connections, or alternatively, Class 3 connections can be used to set/get individual parameters.

ODVA also defines Electronic Data Sheets (EDS) that specify the connections and parameters that are available in the device. The SLA Series EtherNet/IPTM device has EDS files available on the Brooks Instrument website. Your EIP network configuration tool may be able to read EDS files directly to facilitate the configuration process.

The SLA Series Ethernet/IP devices also contains an embedded web interface for configuration and troubleshooting. To access the web interface, see section 'TCP/IP Network Configuration' in this manual.

The SLA Series MFC/MFM supports many different configurable attributes. The out-of-box defaults meet the needs of a great majority of applications, but some applications may require the device to report more information or behave differently than is configured with default settings, such as valve position, safe mode, flow and/or setpoint engineering units, etc.

This section covers the more common attributes that are configured to meet the unique needs of applications. The terms "attribute" and "parameters" can be used interchangeably and ultimately refer to the same data item within the MFC device. The term "parameter" is widely used within the EDS paradigm whereas "attribute" is used within the ODVA specification.

The following tables will reference both the EDS Parameter name (if the configuration software utilizes the EDS sheet) and the EPATH descriptor (class-instance-attribute) for those who are writing custom or have other types of configuration interfaces.

## Section 5 Configuration

Table 5-1: Commonly Configured Attributes/Parameters

Attribute	EDS Parameter	EPATH	Default	Semantics
Flow Meter Data Units	Flow_Unit	[0xA9-1-4]	4103 (0x1007)	See Next Section: Data Units
Flow Controller Data Units	Ctrl_Units	[0x9E-1-4]	4103 (0x1007)	See Next Section Data Units
Temperature Meter Data	Temp_Units	[0xA4-1-4]	4608 (0x1200)	See Next Section Data Units
Selected Gas Calibration	Cal_Instance	[0xA9-1-35]	1	The instance of the Gas Calibration Object used to linearize the Flow Sensor
Valve Driver Safe State	Safe_State	[0x96-1-21]	0 (Close)	The valve will close when the device is in its Safe State
Status Alarm Mask	Alarm_Mask	[0xB8-1-8]	0x00000000	All Alarm Bits are masked
Status Warning Mask	Warning_Mask	[0xB8-1-9]	0x00000000	All Warning Bits are masked

## Data Units

The SLA Series MFC can report flow and accept setpoints in values associated to engineering units. This can simplify user interpretation of information from the device by letting the device perform the calculations necessary to interpret the flow signal from its internal sensor based upon information in the selected calibration.

Table 5-2: Commonly Configured Parameters/Parameters

Parameter	EPATH	Applicable Units Table	Default
Flow Sensor Data Units	[0xA9-1-4]	Appendix C: Table 9-2 Volumetric Flow Units Table	Percent
Flow Totalizer Data Units	[0xA9-1-125]	Appendix C: Table 9-5 Volume Units Table	Liters
Flow Control Data Units	[0x9E-1-4]	Appendix C: Table 9-2 Volumetric Flow Units Table	Percent
Temperature Data Units	[0xA4-1-4]	Appendix C: Table 9-4 Temperature Units	deg C

## Section 5 Configuration

### Safe Mode

All products in the SLA Series product line employ an internal State Machine to govern the operational mode of the device. One particular operational mode is the Safe Mode (a.k.a. the Safe State). For MFC(s), Safe Mode stops the controller and forces the valve actuator to a defined state (see section Valve Safe Mode). By default, the valve actuator will be closed. The state of the actuator in Safe Mode can be configured in the Valve Actuator object, parameters [0x96-1-21] and [0x96-1-22].

The device will be in Safe Mode when any of the following conditions exist:

- If any Error Status bit is set [0xB8-1-4]
- If no Class 1 connection is active
- If the Class 1 connection is closed or times out
- If a Class 1 connection is active and the Run/Idle flag is set to Idle<sup>1</sup>

### Valve Safe Mode

The valve safe mode is the state the valve actuator will be in when the device is in Safe Mode. To configure the safe mode of the valve, use attribute 'Actuator Safe State' in the Valve Driver Object [0x96-1-21]. These states apply to both Normally Closed and Normally Open Valves.

Table 5-3: Safe State

Value	State
0	Closed (default)
1	Open
2	Hold
3	Use Safe Value

<sup>1</sup> The Class 1 Exclusive Owner connection message to the target device contains a header with certain flags required by the target device for proper operation. One of these flags is the Run/Idle flag. Setting of the Run/Idle flag is a function of the master/controller software. Consult your specific master/controller tools for setting this flag. One example would be changing the run mode of a PLC (run mode or program mode) would set/clear this flag. If the Run/Idle flag is set to Run, the device will be in the Executing State, otherwise the device will be in the Safe Mode.

## Process Gas Page Configuration

If the MFC/MFM contains multiple calibrations, the selection of a particular calibration can be configured in attribute 'Calibration Instance' of the Flow Meter Object [0xA9-1- 35].

The value of this attribute is limited to the number of Flow Calibration Objects configured in the device. The minimum value is 1, which is also the default value.

Additionally, the calibration can be selected using the Calibration Instance field in output Assembly instance 101 for MFC's and Assembly instance 102 for MFM's. A value of 0 in this field is ignored by the device. If the field is set to an invalid value, calibration will not change and the 'Invalid Cal Page Selected' alarm status will be set.



## Section 5 Configuration

## Class 1 Connections

The following tables describe the available Class 1 connection configurations in the device. See section 'Data Assemblies' for assembly sizes and details on the data fields within each assembly.

## MFC

Table 5-4: MFC Class 1 Connection Configuration

Name	Connection Type	Configuration Assembly	Output (Consume) Assembly	Input (Produce) Assembly
Ctrl/Mon XO	Exclusive Owner	-	101	201
Process Data 1 I/O	Input Only	-	300	201
Process Data 2 I/O	Input Only	-	301	202
Process Data 1 L/O	Listen Only	-	302	201
Process Data 2 L/O	Listen Only	-	303	202
Process Data 1 L/O w/ Config <sup>1</sup>	Input Only	100	304	201
Process Data 2 L/O w/ Config <sup>1</sup>	Input Only	100	309	202
Ctrl/Mon & Process Data XO <sup>1</sup>	Exclusive Owner	-	101	204
Ctrl/Mon & Process Data XO x/ Config <sup>1</sup>	Exclusive Owner	100	101	204

<sup>1</sup>Only available in Product Revision 4.7

## MFM

Table 5-5: MFM Class 1 Connection Configurations

Name	Connection Type	Configuration	Output (Consume)	Input (Produce)
Ctrl/Mon XO	Exclusive Owner	-	102	203
Process Data 1 I/O	Input Only	-	300	202
Process Data 2 I/O	Input Only	-	301	203
Process Data 1 L/O	Listen Only	-	302	202
Process Data 2 L/O	Listen Only	-	303	203
Ctrl/Mon XO w/ Config	Exclusive Owner	100	102	203
Process Data 1 I/O w/ Config	Input Only	100	304	202
Process Data 2 I/O w/ Config	Input Only	100	307	203
Process Data 1 L/O w/ Config	Listen Only	100	306	202
Process Data 2 L/O w/ Config	Listen Only	100	307	203
Process Data 1 L/O w/ Config <sup>1</sup>	Input Only	100	308	202
Process Data 2 L/O w/ Config <sup>1</sup>	Input Only	100	309	203
Ctrl/Mon & Process Data XO <sup>1</sup>	Exclusive Owner	-	102	205
Ctrl/Mon & Process Data XO x/ Config <sup>1</sup>	Exclusive Owner	100	102	205

<sup>1</sup>Only available in Product Revision 4.7

## Section 5 Configuration

### Data Assemblies

#### Configuration Assembly

The configuration assembly can be used to get or set configuration values in the device. Depending on the application tools for the master scanner, this configuration data can be sent to the device when Class 1 connections are created with the device. This data can also be accessed through message exchanges by reading or writing class 4, instance 100, attribute 3. If the configuration data is sent to the device using this assembly, all the data fields in the assembly must be a valid value otherwise all the data will be rejected. Refer to the object definitions for more information on parameter in this assembly.

## Section 5 Configuration

Configuration Assembly Instance ID: 100

Device Type: MFC

Assembly Size: 180 Bytes / 45 Words

Table 5-6: MFC Configuration Assembly Definition

Parameter	Class	Inst	ID	Data Type	Byte Offset	Data Size	Description
Flow Data Units	169	1	4	DINT	0	4	Flow Engineering Units
Totalizer Units	169	1	125	DINT	4	4	Totalizer Engineering Units
Calibration Instance	169	1	35	DINT	8	4	Selected Process Gas Instance
Flow Alarm Trip Point High	169	1	17	REAL	12	4	High Flow Alarm Trip Point
Flow Alarm Trip Point Low	169	1	18	REAL	16	4	Low Flow Alarm Trip Point
Flow Alarm Hysteresis	169	1	19	REAL	20	4	Flow Alarm Hysteresis
Flow Alarm Settling Time	169	1	20	DINT	24	4	Flow Alarm Settling Time
Flow Warning Trip Point High	169	1	21	REAL	28	4	High Flow Warning Trip Point
Flow Warning Trip Point Low	169	1	22	REAL	32	4	
Flow Warning Hysteresis	169	1	23	REAL	36	4	
Flow Warning Settling Time	169	1	24	DINT	40	4	
Zero Operation Duration	169	1	105	DINT	44	4	Duration for Sensor Zero Operations
No Flow Threshold	169	1	222	REAL	48	4	No Flow Limit Threshold
No Flow Settling Time	169	1	223	DINT	52	4	No Flow Limit Settling Time
Choked Flow Threshold	169	1	224	REAL	56	4	Choked Flow Limit Threshold
Choked Flow Settling Time	169	1	225	DINT	60	4	Choked Flow Limit Settling Time
Zero Warning Time	169	1	140	DINT	64	4	Time since last zero warning limit
Zero Warning Settling Time	169	1	141	DINT	68	4	Delay time after zero setpoint to check zero quality
Zero Warning Band	169	1	142	REAL	72	4	Excessive drift warning band
Zero Success Band	169	1	143	REAL	76	4	Sensor zero operation success band
Back Stream Flow Limit	169	1	228	REAL	80	4	Backstream flow threshold
Back Stream Settling Time	169	1	229	DINT	84	4	Backstream flow settling time
Valve Warning Trip Point High	150	1	18	REAL	88	4	Valve High Warning Trip Point
Valve Warning Trip Point Low	150	1	19	REAL	92	4	Valve Low Warning Trip Point
Valve Warning Hysteresis	150	1	20	REAL	96	4	Valve Warning Hysteresis
Valve Safe State	150	1	21	DINT	100	4	Valve Safe State
Valve Safe Value	150	1	22	REAL	104	4	Valve Safe Value

## Section 5 Configuration

Parameter	Class	Inst	ID	Data Type	Byte Offset	Data Size	Description
Controller Data Units	158	1	4	DINT	108	4	Flow Controller Engineering Units
Controller Warning Settling Time	158	1	15	DINT	112	4	Flow Controller Deviation Warning Settling Time
Controller Warning Error Band	158	1	16	REAL	116	4	Flow Controller Deviation Warning Error Band
Reamp Time	158	1	19	REAL	120	4	Flow Controller Ramp Time
Setpoint Limit	158	1	194	REAL	124	4	Flow Controller Setpoint Limit Value
Setpoint Limit Action	158	1	201	DINT	128	4	Flow Controller Setpoint Limit Behavior
Temperature Data Units	164	1	4	DINT	132	4	Temperature Engineering Units
Temperature Warning Trip Point High	164	1	21	REAL	136	4	High Temperature Warning Trip Point
Temperature Warning Trip Point Low	164	1	22	REAL	140	4	Low Temperature Warning Trip Point
Temperature Warning Settling Time	164	1	24	DINT	144	4	Temperature Warning Settling Time
Active Alarms Mask	184	1	8	DWORD	148	4	Alarms Bit Mask
Active Warnings Mask	184	1	9	DWORD	152	4	Warnings Bits Mask
Supply Voltage Warning Trip Point Low	100	1	191	REAL	160	4	Device power supply voltage warning high trip point
Supply Voltage Warning Trip Point High	100	1	192	REAL	160	4	Device power supply voltage warning low trip point
Supply Voltage Warning Settling Time	100	1	193	DINT	164	4	Device power supply voltage warning settling time
Zero Button Disable	100	1	147	DINT	168	4	Disables the zero button
Valve Control Warning Limit	150	1	143	REAL	172	4	Sets the threshold for the Valve Control Warning diagnostic
Valve Control Warning Settle Time	150	1	144	DINT	176	4	Sets the settling time for the Valve Control Warning Diagnostic

## Section 5 Configuration

Configuration Assembly Instance ID: 100

Device Type: MFM

Assembly Size: 112 Bytes / 28 Words

Table 5-7: MFM Configuration Assembly Definition

Parameter	Class	Inst	ID	Data Type	Byte Offset	Data Size	Description
Flow Data Units	169	1	4	DINT	0	4	Flow Engineering Units
Totalizer Units	169	1	125	DINT	4	4	Totalizer Engineering Units
Calibration Instance	169	1	35	DINT	8	4	Selected Process Gas Instance
Flow Alarm Trip Point High	169	1	17	REAL	12	4	High Flow Alarm Trip Point
Flow Alarm Trip Point Low	169	1	18	REAL	16	4	Low Flow Alarm Trip Point
Flow Alarm Hysteresis	169	1	19	REAL	20	4	Flow Alarm Hysteresis
Flow Alarm Settling Time	169	1	20	DINT	24	4	Flow Alarm Settling Time
Flow Warning Trip Point High	169	1	21	REAL	28	4	High Flow Warning Trip Point
Flow Warning Trip Point Low	169	1	22	REAL	32	4	Low Flow Warning Trip Point
Flow Warning Hysteresis	169	1	23	REAL	36	4	Flow Warning Hysteresis
Flow Warning Settling Time	169	1	24	DINT	40	4	Flow Warning Settling Time
Zero Operation Duration	169	1	105	DINT	44	4	Duration for Sensor Zero Operations
Zero Warning Time	169	1	140	DINT	48	4	Time since last zero warning limit
Zero Warning Settling Time	169	1	141	DINT	52	4	Delay time after zero setpoint to check zero quality
Zero Warning Band	169	1	143	REAL	60	4	Sensor zero operation success band
Zero Success Band	169	1	143	REAL	60	4	Sensor zero operation success band
Back Stream Flow Limit	169	1	228	REAL	64	4	Backstream flow threshold
Back Stream Settling Time	169	1	229	DINT	68	4	Backstream flow settling time
Temperature Data Units	164	1	4	DINT	72	4	Temperature Engineering Units
Temperature Warning Trip Point High	164	1	21	REAL	76	4	High Temperature Warning Trip Point
Temperature Warning Trip Point Low	164	1	22	REAL	80	4	Low Temperature Warning Trip Point
Temperature Warning Settling Time	164	1	24	DINT	84	4	Temperature Warning Settling Time
Active Alarms Mask	184	1	8	DWORD	88	4	Alarms Bit Mask
Active Warnings Mask	184	1	9	DWORD	92	4	Warnings Bit Mask
Supply Voltage Warning Trip Point Low	100	1	191	REAL	96	4	Device power supply voltage high warning trip point
Supply Voltage Warning Trip Point High	100	1	192	REAL	100	4	Device Power supply voltage warning low trip point
Supply Voltage Warning Settling Time	100	1	193	DINT	104	4	Device power supply voltage warning settling time
Zero Button Disable	100	1	147	DINT	108	4	Disables the zero button

## Section 5 Configuration

### Output Assemblies

These assemblies are used to send data to the device. From the master scanner perspective these are outputs. Each assembly is defined to be used with a certain type of connection: Exclusive Owner, Input Only, and Listen Only. See Appendix A for more information on connection types. Refer to the object definitions for more information on parameter in this assembly.

#### Process Control 1

**Assembly Instance ID: 101**

**Device Type: MFC**

**Assembly Size: 24 Bytes / 12 Words**

Table 5-8: Process Control 1 Assembly

Parameter	Class	Inst	ID	Data Type	Byte Offset	Data Size	Description
Setpoint	158	1	6	REAL	0	4	Flow controller setpoint
Valve Override	150	1	5	DINT	4	4	Valve Actuator Override Mode
Control Mode	158	1	5	DINT	8	4	Flow controller operational mode
Fixed Control Mode Value	158	1	159	REAL	12	4	Flow controller fixed controller mode actuator drive value
Custom Flow Totalizer Control	169	1	131	DINT	16	4	Sets the operational state of the custom flow totalizer
Calibration Instance	169	1	35	DINT	20	4	Selects the calibration page to be used by the flow meter

#### Null Data

**Instance ID: 300 to 307**

**Device Type: MFC/MFM**

**Assembly Size: 0 Bytes / 0 Words**

#### Assembly Definition

Null Data assemblies are used for Listen Only or Input Only connections where no data is sent to the device, but an endpoint assembly must be defined when the connection is established.

#### Dummy Data Product Revision 4.7 and greater

**Instance ID: 308 to 309**

**Device Type: MFC/MFM**

**Assembly Size: 6 Bytes**

#### Assembly Definition

Dummy Data assemblies are used for Listen Only or Input Only connections where dummy data is sent to the device, but an endpoint assembly must be defined when the connection is established. The value of the dummy data is ignored by the device.

Although the assembly size is 6 bytes, when using DeltaV™ with a PK Controller, the output size in DeltaV™ needs to be configured for 2 bytes because the PK Controller pads the data to become 6 bytes, at the time of publication of this manual. DeltaV™ and the PK Controller are Emerson products. Please contact Emerson with any questions about their configuration.

## Section 5 Configuration

### Input Assemblies

These assemblies are used to retrieve data from the device. From the scanner perspective these are inputs. Each assembly is defined to be used with a certain type of connection: Exclusive Owner, Input Only, and Listen Only. See Appendix A for more information on connection types. Refer to the object definitions for more information on parameter in this assembly.

### Detailed Process Monitoring

**Instance ID: 201**

**Device Type: MFC**

**Assembly Size: 28 Bytes / 14 Words**

*Table 5-9: Detailed Process Monitoring Assembly*

Parameter	Class	Inst	ID	Data Type	Byte Offset	Data Size	Description
Flow	169	1	6	REAL	0	4	Flow sensor value
Valve Position	150	1	6	REAL	4	4	Valve actuator position
Live Setpoint	158	1	202	REAL	8	4	Active setpoint
Active Alarms	184	1	4	DWORD	12	4	Active Alarms
Active Warnings	184	1	5	DWORD	16	4	Active Warnings
Active Errors	184	1	3	DWORD	20	4	Active Errors
Device Status	184	1	6	DWORD	24	4	Device Status

## Section 5 Configuration

**Totalizers and Other Process Conditions****Instance ID: 202****Device Type: MFC and MFM****Assembly Size: 44 Bytes / 22 Words***Table 5-10: Totalizers and Other Process Conditions Assembly*

Parameter	Class	Inst	ID	Data Type	Byte Offset	Data Size	Description
Flow Totalizers	169	1	126	REAL	0	4	Flow sensor totalizer
Flow Hours	169	1	96	DINT	4	4	Total flow hours
Custom Flow Totalizer	169	1	130	REAL	8	4	Custom flow sensor totalizer
Temperature	164	1	6	REAL	12	4	Temperature
Process Gas Full Scale	102	Active Instance <sup>1</sup>	45	REAL	16	4	Selected process gas page calibrated full scale
Process Gas Calibration Instance	169	1	35	DINT	20	4	Selected process gas page
Process Gas Standard Number	102	Active Instance <sup>1</sup>	40	DINT	24	4	Selected process gas page gas standard number
FAT Date	102	Active Instance <sup>1</sup>	300	DINT	28	4	Factory acceptance date
Device Input Supply Volts	100	1	190	REAL	32	4	Input voltage to MFC/MFM
Process Gas Data Units	102	Active Instance <sup>1</sup>	42	DINT	36	4	Selected process gas page calibration engineering units
Process Gas Flow Hours Totalizer	102	Active Instance <sup>1</sup>	47	REAL	40	4	Total flow hours for the selected process gas page

<sup>1</sup> The Active Instance is selected by attribute Process Gas Calibration Instance [169-1-35]



## Section 5 Configuration

**Flow and Detailed Device Status****Instance ID: 203****Device Type: MFM****Assembly Size: 20 Bytes / 10 Words***Table 5-11: Flow and Detailed Device Status Assembly*

<b>Parameter</b>	<b>Class</b>	<b>Inst</b>	<b>ID</b>	<b>Data Type</b>	<b>Byte Offset</b>	<b>Data Size</b>	<b>Description</b>
Flow	169	1	6	REAL	0	4	Flow sensor value
Active Alarms	184	1	4	DINT	4	4	Active Alarms Status
Active Warnings	184	1	5	DINT	8	4	Active Warnings Status
Active Errors	184	1	3	DINT	12	4	Active Errors Status
Device Status	184	1	6	DINT	16	4	Active Device Status

## Section 5 Configuration

**Detailed Process Monitoring, Totalizers and Other Process Conditions****Instance ID: 204****Device Type: MFC****Assembly Size: 72 Bytes / 18 Words**

Table 5-12: Flow and Detailed Device Status Assembly

Parameter	Class	Inst	ID	Data Type	Byte Offset	Data Size	Description
Flow	169	1	6	REAL	0	4	Flow sensor value
Valve Position	150	1	6	REAL	4	4	Valve actuator position
Live Setpoint	158	1	202	REAL	8	4	Active setpoint
Active Alarms	184	1	4	DWORD	12	4	Active Alarms
Active Warnings	184	1	5	DWORD	16	4	Active Warnings
Active Errors	184	1	3	DWORD	20	4	Active Errors
Device Status	184	1	6	DWORD	24	4	Device Status
Flow Totalizer	169	1	126	REAL	28	4	Flow sensor totalizer
Flow Hours	169	1	96	DINT	32	4	Total flow hours
Custom Flow Totalizer	169	1	130	REAL	36	4	Custom flow sensor totalizer
Temperature	164	1	6	REAL	40	4	Temperature
Process Gas Full Scale	102	Active Instance <sup>1</sup>	45	REAL	44	4	Selected process gas page calibrated full scale
Process Gas Calibration Instance	169	1	35	DINT	48	4	Selected process gas page
Process Gas Standard Number	102	Active Instance <sup>1</sup>	40	DINT	52	4	Selected process gas page gas standard number
FAT Date	102	Active Instance <sup>1</sup>	300	DINT	56	4	Factory acceptance date
Device Input Supply Volts	100	1	190	REAL	60	4	Input voltage to MFC/MFM
Process Gas Data Units	102	Active Instance <sup>1</sup>	42	DINT	64	4	Selected process gas page calibration engineering units
Process Gas Flow Hours Totalizer	102	Active Instance <sup>1</sup>	47	REAL	68	4	Total flow hours for the selected process gas page

<sup>1</sup> The Active Instance is selected by attribute Process Gas Calibration Instance [169-1-35]

## Section 5 Configuration

**Detailed Process Monitoring, Totalizers and Other Process Conditions****Instance ID: 205****Device Type: MFM****Assembly Size: 64 Bytes / 16 Words***Table 5-13: Detailed Process Monitoring, Totalizers and Other Process Conditions*

Parameter	Class	Inst	ID	Data Type	Byte Offset	Data Size	Description
Flow	169	1	6	REAL	0	4	Flow sensor value
Active Alarms	184	1	4	DWORD	4	4	Active Alarms
Active Warnings	184	1	5	DWORD	8	4	Active Warnings
Active Errors	184	1	3	DWORD	12	4	Active Errors
Device Status	184	1	6	DWORD	16	4	Device Status
Flow Totalizer	169	1	126	REAL	20	4	Flow sensor totalizer
Flow Hours	169	1	96	DINT	24	4	Total Flow Hours
Custom Flow Totalizer	169	1	130	REAL	28	4	Custom flow sensor totalizer
Temperature	164	1	6	REAL	32	4	Temperature
Process Gas Full Scale	102	Active Instance <sup>1</sup>	45	REAL	36	4	Selected process gas page calibrated full scale
Process Gas Calibration Instance	169	1	35	DINT	40	4	Selected process gas page
Process Gas Standard Number	102	Active Instance <sup>1</sup>	40	DINT	44	4	Selected process gas page gas standard number
FAT Date	102	Active Instance <sup>1</sup>	300	DINT	48	4	Factory acceptance date
Device Input Supply Volts	100	1	190	REAL	52	4	Input voltage to MFC/MFM
Process Gas Data Units	102	Active Instance <sup>1</sup>	42	DINT	56	4	Selected process gas page calibration engineering units
Process Gas Flow Hours Totalizer	102	Active Instance <sup>1</sup>	47	REAL	60	4	Total flow hours for the selected process gas page

<sup>1</sup> The Active Instance is selected by attribute Process Gas Calibration Instance [169-1-35]

## Section 6 Detailed Configuration

### Overview

This section is recommended for advanced users of EtherNet/IP™ and Brooks Instrument MFC/ MFM products.

This section details all the Classes, Instances, Attributes and Services supported by the SLA58xx Series MFC/MFM. Differences between the MFC and MFM device types are noted as exceptions in each subsection. The classes detailed in the following sections can be categorized into the following functional groups to indicate what aspect of the device is being configured:

Table 6-1: Accessible Classes

Class	ID	Instances	MFC	MFM
Identity Object	1 (0x01)	1	Y	Y
Assembly Object	4 (0x04)	5	Y	Y
Device Management Object	100 (0x64)	1	Y	Y
Process Gas Object	102 (0x66)	1-6, depending on the number of calibrations stored in the device	Y	Y
Value Driver Object	150 (0x96)	1	Y	N/A
Flow Controller Object	169 (0xA9)	1	Y	Y
Temperature Meter Object	164 (0xA4)	1	Y	Y
Flow Meter Object	169 (0xA9)	1	Y	Y
Status Object	184 (0xB8)	1	Y	Y

In the ODVA specification, Instance 0 of both attributes and services are referred to as Class Level attributes and services. Instance 1 and higher are referred to as Instance Level attributes and services. This document will refer to all Levels by their instance number to avoid possible confusion.

The following details the meaning of the table heading names:

**Attribute ID:** The ID number of the attribute.

**Name:** The ODVA Specification label for the attribute.

**Data Type:** The ODVA Data Type for this attribute. See Appendix B for the definition of each data type.

**Access Rule:** “Get” means that the value of this attribute is “Read Only”. “Set” means that the value of this attribute can be read and/or written.

**NV:** “NV” = The value of the attribute is stored in non-volatile memory and its value will be retained after a power cycle.

**V:** “V” = The value of the attribute is in volatile memory and its value will be returned to default after a power cycle.

**Description:** A brief description of the meaning of the attribute.

**Notes:** Any additional notations of importance about the attribute. These notes will be found in the same section as the table.

## Section 6 Detailed Configuration

### Services

Services are operations or functions that can be invoked against an object. Services are invoked using Class 3 messaging (request/response). The services list in the table below are supported for all the objects define in this document. Other services specific to an object are included with the object description.

Table 6-2: Common Services for all Objects

Service Code	Service Name	Service Description	Details
0x0E	Get Attribute Single	Returns the contents of the specified attribute	Appendix D: Get Attribute Single
0x10	Set Attribute Single	Writes the contents of the specified attribute	Appendix D: Set Attribute Single

### Identity Object [0x01]

Device Type(s): MFC and MFM

The Identity Object contains informational attributes that uniquely describe the device.

**Example:**

The use of attributes Vendor ID, Device Type, Product Code, and Serial Number together uniquely describe this device from any other device.

### Attributes

Table 6-3: Identity Instance Attributes

Attrib ID	Name	Data Type	Access Rule	NV	Description	Notes
1	Vendor ID	UINT	Get	NV	ID Number assigned to Vendor by ODVA.	Brooks Instrument ID = 246
2	Device Type	UINT	Get	NV	Numeric identifier indicating the ODVA Device Profile implemented by the device.	Device Type = 43 (0x2B) See 'Note: Device Type' below
3	Product Code	UINT	Get	NV	Identification of a product of an individual vendor.	MFC = 6, MFM = 7
4	Revision	STRUCT of:	Get	NV	Revision of the device the Identity Object represents.	See 'Note: Revision' below
	Major Revision	USINT				
	Major Revision	USINT				
5	Status	WORD	Get	V	Summary status of the device.	See 'Note: Status' below
6	Serial Number	UDINT	Get	NV	Serial number of the device.	See 'Note: Serial Number' below
7	Product Name	SHORT STRING	Get	NV	Human readable Identification.	

## Section 6 Detailed Configuration

### Note: Device Type

The device profile includes both an Identity and the Device Management Objects. Both objects contain an attribute that defines the kind of device this implementation supports. In this object the Device Type is assigned a numeric value of 0x2B. This number corresponds to the device profile ID contained in the ODVA specification. This attribute should not be confused with the Device Manager Device Type attribute [0x64, 1, 1] which is represented as a STRING (Short String) data type.

### Note Revision

The ODVA specification defines Major Revision as a significant change to the fit, form, or function of the product. Minor Revision is defined as changes that do not affect user configuration choices such as bug fixes, hardware component change, labeling change, etc.

### Note Status

The Status attribute of the Identity Object represents a summary status of the entire device. The definition of each bit in this attribute is defined by the ODVA EtherNet/IP™ specification. The Status Object (0xB8) provides detailed status of the operation of the MFC.

Table 6-4: Identity Object Status

Bit	Label	Description
0	Owned	A Value of (1) indicates a Class 1 connection of type Exclusive Owner has been established with the device. Otherwise, this bit will have a value of (0)
1-7	Reserved	Always 0
8	Minor Recoverable Fault	One or more Warning Status bits are set in the Status Object (184) attribute (5)
9	Reserved	Always 0
10	Major Recoverable Fault	One or more Alarm Status bits are set in the Status Object (184) attribute (4)
11	Major Unrecoverable Fault	One or more Error Status bits are set in the Status Object (184) attribute (3)
12-15	Reserved	Always 0

## Section 6 Detailed Configuration

### Note: Serial Number

This Serial Number attribute differs from the Device Manager Serial Number attribute [0x64, 1, 9] whereby the Identity Object attribute [0x01, 1, 6] is strictly a numeric value that is guaranteed to be unique by the manufacturer across all ...the manufacturer's products. The Device Manager attribute 'Serial Number' is a string value that should represent the manufacturer's method of defining serial numbers for its products.

### Services

#### Reset

Table 6-5: Identity Object Reset Service Arguments

Parameter Name	Data Type	Required	Parameter Value	Semantics
Type	USINT	N	0	Emulate as closely as possible cycling power on the item the Identity Object represents. This value is the default if this parameter is omitted (default).
			1	Return as closely as possible to the out-of-box configuration, then as closely as possible emulate cycling power.

Table 6-6: Identity Object Reset Service Response

Parameter Name	Data Type	Required	Parameter Value	Semantics
NO RESPONSE DATA				

## Section 6 Detailed Configuration

### Assembly Object [0x04]

Device Type(s): MFC and MFM

The Assembly Object contains a list of attributes that data can be written to (sink) and read from (source) via the Data Buffer (3) attribute contained in this object. The Assembly Object is generally assigned as the endpoint of an I/O Connection object (assigned via the Path attributes in the Connection Object). In this way, multiple pieces of data can be moved to and from the device with a reduced number of network messages. Assembly definitions supported by SLA Series MFC/MFM are defined in Section 5, 'Data Assemblies.'

### Attributes

Table 6-7: Assembly Object Instance Attributes

Attrib ID	Name	Data Type	Access Rule	NV	Description	Notes
3	Data Buffer	ARRAY of BYTE	Conditional	NV	Zero or more attributes that comprise the Data Buffer	If the assembly is used as an endpoint in an active Class 1 connection, then this attribute will be Get only. Writing to this attribute will return a Device State conflict error

### Services

No Object Specific Services



## Section 6 Detailed Configuration

### Device Manager Object [0x64]

Device Types: MFC and MFM

The Device Manager Object contains product information about the SLA Series MFC/ MFM device such as serial number, model number, firmware revisions, etc. The object also captured device level operational parameters not specific to any other application object defined in the device.

### Attributes

Table 6-8: Device Manager Instance Attributes

Attrib ID	Name	Data Type	Access Rule	NV	Description	Notes
1	Device Type	SHORT STRING	Get	NV	Device model name	Max. 8 characters 'MFC' of 'MFM'
3	Manufacturer's Name	SHORT STRING	Get	NV	The name of the manufacturer of the device	Max. 20 characters 'Brooks Instrument'
4	Manufacturer's Model Number	SHORT STRING	Get	NV	The manufacturer specified model number for the device	Max. 20 characters
5	Software Revision Level	SHORT STRING	Get	NV	Revision level of the firmware in the device	Note: 'Revision Levels' below
6	Hardware Revision Level	SHORT STRING	Get	NV	Revision level of the hardware in the device	
7	Manufacturer's Serial Number	SHORT STRING	Get	NV	Serial number of device assigned by the manufacturer	Max. 30 characters
8	Device Configuration	SHORT STRING	Get	NV	Any additional manufacturer specific information about the device	Max. 50 characters 'N/A'
103	Main Board Bootloader Version	SHORT STRING	Get	NV	Revision level of the Main Board Bootloader firmware	Max. 8 characters (See Section Revision Level)
104	Device Configuration ID	DINT	Get	NV	Configuration Level of the device assigned by the manufacturer	
147	Zero Button Disable	DINT	Set	NV	Disables the ability to zero the device using the external button	
190	Supply Voltage	REAL	Get	V	Input supply voltage to the device in Volts	Volts
191	Supply Voltage Minimum Warning Limit	REAL	Set	NV	Minimum threshold, in Volts, to set the Supply Volts Low Warning bit	(See Section Note: Supply Voltage) (See Section Note: Status)
192	Supply Voltage Maximum Warning Limit	REAL	Set	NV	Maximum threshold, in volts, to set the Supply Volts Low Warning bit	(See Section Note: Supply Voltage) (See Section Note: Status)

## Section 6 Detailed Configuration

Attrib ID	Name	Data Type	Access Rule	NV	Description	Notes
193	Supply Voltage Warning Settling Time	DINT	Set	NV	The amount of time, in milliseconds, the warning condition must exist before the warning bit is set	(See Section Note: Supply Voltage)  (See Section Note: Status)
222	Power On Hours	REAL	Get	NV	Power on time totalizer	Hours
250	Communications Board Firmware Revision Level	SHORT STRING	Get	NV	Revision level of the communications board firmware	Max. 10 characters. (See Section: Revision Level)
251	Communications Board Hardware Revision Level	SHORT STRING	Get	NV	Revision level of the communications board hardware	Max. 10 characters. (See Section: Revision Level)
252	Communications Board Bootloader Revision Level	SHORT STRING	Get	NV	Revision level of the communications bootloader firmware	Max. 10 characters. (See Section: Revision Level)

## Section 6 Detailed Configuration

### Note: Status

Status bits associated with this object are listed below. See section 7 for details on specific status and behavior.

- **[Active\_Warnings]{184-1-5}, Bit 26:** Supply Voltage High
- **[Active\_Warnings]{184-1-5}, Bit 27:** Supply Voltage Low

### Note: Revision Level

Attributes representing firmware revisions running in the device are comprised of the major and minor revision level, separated by a decimal point (for example, 1.04).

### Note: Supply Voltage

The Device Manager Object reports the input supply voltage to device. Warning status bits (See Status Object section) can be used to indicate high or low input voltage condition. Setting attributes 191 and 192 set the threshold values for setting the status flags. The statuses are self-clearing when the voltage returns within nominal range. Attribute 193 can be configured to delay the setting or clearing of the status to minimize spurious indications.

## Services

Table 6-9: Device Manager Services

Service Code	Service Name	Service Description
0x06	Start	Moves the device from Safe State to Executing State
0x07	Stop	Moves the device from Executing State to Safe State

## Start

Table 6-10: Device Manager Parameters

Parameter	Byte Offset	Details
No Parameters for Start Service		

Table 6-11: Start Service Return

Return Code	Description	Return Data Count	Details
0	Success	0	Moves the device from Safe State to Executing State
12	Object State Conflict	0	A cyclic connection to the device is active and will not execute the service
11	Already in Requested Mode	0	The device is already the requested mode or state

## Section 6 Detailed Configuration

### Stop

Table 6-12: Stop Service Parameters

Parameter	Byte Offset	Details
No Parameters for Stop Service		

Table 6-13: Stop Service Return

Return Code	Description	Return Data Count	Details
0	Success	0	Service executed normally
12	Object State Conflict	0	A cyclic connection to the device is active and will not execute the service
11	Already in Requested Mode	0	The device is already the requested mode or state

### Flow Meter Object [0xA9]

Device Types: MFC and MFM

The Flow Meter Object is responsible for reporting flow sensor values. The Flow Meter Object in conjunction with the selected Flow Meter Object can linearize the sensor values and convert measurements into engineering data units.

### Attributes

Table 6-14: Flow Meter Instance Attributes

Attrib ID	Name	Data Type	Access Rule	NV	Description	Notes
4	Data Units	ENGUNITS	Set	NV	Defines the Engineering Units context of Flow [6] and other attributes in this object	(See 'Note: Data Units' below) Default = Percent
6	Flow	REAL	Get	V	The amount of flow going through the sensor	This value is corrected, converted, and calibrated to report the actual value of flow. Data Units set by [4]
17	Alarm Trip Point High	REAL	Set	NV	Determines the Flow [6] value above which an Alarm Condition will occur	(See 'Note: Status' below) Data Units set by [4]
18	Alarm Trip Point Low	REAL	Set	NV	Determines the Flow [6] value below which an Alarm Condition will occur	(See 'Note: Status' below) Data Units set by [4]

## Section 6 Detailed Configuration

Attrib ID	Name	Data Type	Access Rule	NV	Description	Notes
19	Alarm Hysteresis	REAL	Set	NV	The amount by which Flow [6] must recover past the Trip Point threshold ([17] and [18]) to clear the associated status condition	(See 'Note: Status' below) Data Units set by [4]
20	Alarm Settling Time	DINT	Set	NV	Determines the time that the Flow [6] value must exceed the Trip Point before the exception condition is generated	(See 'Note: Status' below) Time in milliseconds
21	Warning Trip Point High	DINT	Set	NV	Determines the Flow [6] value above which a Warning Condition will occur	(See 'Note: Status' below) Data Units set by [4]
22	Warning Trip Point Low	REAL	Set	NV	Determines the Flow [6] value below which a Warning Condition will occur	(See 'Note: Status' below) Data Units set by [4]
23	Warning Hysteresis	REAL	Set	NV	The amount by which Flow [6] must recover past the Trip Point threshold ([21] and [22]) to clear the associated status condition	(See 'Note: Status' below) Data Units set by [4]
24	Warning Settling Time	DINT	Set	NV	Determines the time that the Flow [6] value must exceed the Trip Point before the exception condition is generated	(See 'Note: Status' below) Time in milliseconds
35	Gas Calibration Object Instance	DINT	Set	NV	Configures which S-Gas Calibration Object Instance is currently active for this object	(See 'Note: Gas Calibration Object Instance' below)
96	Flow Hours	DINT	Get	NV	Total hours of flow through the device	
105	Zero Duration	DINT	Set	NV	The amount of time used by the device to perform a device zero operation	Time in milliseconds
112	Zero Enable	BOOL	Set	V	Starts a device sensor zero operation	Write '1' to this attribute starts a zero operation provided device status 'Zero Operation Inhibit' is not set  (See Section 7.1.6)
125	Totalizer Units	DINT	Set	NV	The engineering units used to report the totalizer values in this object	(See 'Note: Totalizers' below)

## Section 6 Detailed Configuration

Attrib ID	Name	Data Type	Access Rule	NV	Description	Notes
126	Flow Totalizer	REAL	Set	NV	Total gas flowed through the device	(See 'Note Totalizers' below) Data Units set by [125]
130	Custom Flow Totalizer	REAL	Set	NV	Total gas flowed through the device since the last commanded 'Reset' through Custom Flow Totalizer Control [131]	(See 'Note: Totalizers' below) Data Units set by [125]
131	Custom Flow Totalizer Control	DINT	Set	V	Commands start, stop, and reset of Custom Flow Totalizer	(See 'Note Totalizers' below)
140	Zero Recommend Time	DINT	Set	NV	Time limit since the last zero operations that will set the 'Zero Recommended' status	(See 'Note: Status' below and Section 7.1.5) MFC Only
141	Zero Tolernace Settle Time	DINT	Set	NV	The number of seconds after 0% setpoint that the device will wait before checking 'Zero Recommend' status	(See 'Note: Status' below and Section 7.1.5) MFC Only
142	Zero Tolerance Band	REAL	Set	NV	The tolerance band for which the 'Zero Recommended' status will be set if when setpoint = 0%	(See 'Note: Status' below and Section 7.1.5) 0 = Disabled MFC Only
143	Zero Success Band	REAL	Set	NV	The error band for which the 'Bad Zero Warning' status will be set after completion of a zero operation and the resulting zero exceeds this band	(See 'Note: Status' below and Section 7.2.5)
144	Zero Minimum Drift Time	DINT	Set	NV	The minimum time limit between two successful zero operations that must occur before an excessive zero drift diagnostic will be run.	(See 'Note: Status' below and Section 7.2.4) 0 = Disabled
145	Excessive Zero Drift Multiplier	REAL	Set	NV	A span adjustment to adjust/expand the Expected Drift rate	(See 'Note: Status' below and Section 7.2.4)
146	Excessive Zero Drift Offset	REAL	Set	NV	An offset adjustment to adjust/expand the Expected Drift rate	(See 'Note: Status' below and Section 7.2.4)
148	Total Drift	REAL	Get	NV	The total zero drift since flowing with current gas page	(See 'Note: Status' below and Section 7.2.4)

## Section 6 Detailed Configuration

Attrib ID	Name	Data Type	Access Rule	NV	Description	Notes
149	Zero History Table	STRUCT of:	Get	NV	Data collected on the last 128 zero operations	To retrieve data from the Zero History Table, see 'Service Code 0x32' below
	Calibration Instance	UDINT			The Calibration Instance at the time of the zero operation	
	Zero Drift	REAL			The Zero Drift prior to commencing the zero operation	
	Temperature	REAL			The Temperature, in Celsius, prior to commencing the zero operation	
	Power On Hours	UDINT			Total power on hours at the time of the zero operation	
222	No Flow Limit	REAL	Set	NV	The percentage of setpoint by which if 'Flow' does not exceed will raise an 'Active_Alarms_No_Flow' status is raised	(See 'Note: Status' below and Section 7.3.3)  Units in percent MFC Only
223	No Flow Settling Time	DINT	Set	NV	The time in which a No Flow condition must exist before a status is raised	(See 'Note: Status' below and Section 7.3.3)  Time in milliseconds MFC Only
224	Choked Flow Limit	REAL	Set	NV	The percentage of setpoint by which if 'Flow' does not exceed will raise an 'ActiveWarnings_Choked_Flow' or 'Active_Alarms_Choked_Flow' status is raised	(See 'Note: Status' below and Section 7.2.3 and Section 7.3.3)  Units in percent MFC Only
225	Choked Flow Settling Time	DINT	Set	NV	The time in which a choke flow condition must exist before a status is raised	(See 'Note: Status' below and Section 7.2.3 and 7.3.3)  Time in milliseconds MFC Only
226	Overhaul-Due	DINT	Set	NV	The time remaining in hours until device requires service. When this timer reaches 0, 'Overhaul Due Warning' status shall be set	(See 'Note: Timers' below)

## Section 6 Detailed Configuration

Attrib ID	Name	Data Type	Access Rule	NV	Description	Notes
227	Calibration Due	DINT	Set	NV	The time remaining in hours until the device needs to be recalibrated. When this timer reaches 0, 'Calibration Due Warning' status shall be set	(See 'Note: Timers' below)
228	Backstream Flow Limit	REAL	Set	NV	The threshold by which reverse flow must exceed to raise a backstream error status	(See 'Note: Status' below and Section 7.4.1) Units in percent
229	Backstream Time Limit	DINT	Set	NV	The time in which a backstreaming flow condition must exist before a status is raised	(See 'Note: Status' below and Section 7.4.1) Time in milliseconds
230	Flow Totalizer Overflow Threshold	REAL	Set	NV	The threshold by which Flow Totalizer [126] must exceed before a 'Totalizer Overflow' status is raised	(See 'Note: Status' below and Section 7.2.12)



## Section 6 Detailed Configuration

### Note: Data Units

The value of this attribute is limited to the values specified in the Volumetric Flow Units Table in Appendix C - Data Units.

### Note: Status

Status bits associated with this object are listed below. See section 7 for details on specific status and behavior.

- **[Active\_Errors]{184-1-3}, Bit 2:** Back Streaming Error
- **[Active\_Alarms]{184-1-4}, Bit 0:** Low Flow Alarm
- **[Active\_Alarms]{184-1-4}, Bit 1:** High Flow Alarm
- **[Active\_Alarms]{184-1-4}, Bit 2:** No Flow Alarm
- **[Active\_Alarms]{184-1-4}, Bit 3:** Choked Flow Alarm
- **[Active\_Alarms]{184-1-4}, Bit 15:** Invalid Process Gas Page Selected
- **[Active\_Warnings]{184-1-5}, Bit 0:** Low Flow Warning
- **[Active\_Warnings]{184-1-5}, Bit 1:** High Flow Warning
- **[Active\_Warnings]{184-1-5}, Bit 3:** Choked Flow Warning
- **[Active\_Warnings]{184-1-5}, Bit 4:** Excessive Zero Drift Warning
- **[Active\_Warnings]{184-1-5}, Bit 5:** Bad Zero Warning
- **[Active\_Warnings]{184-1-5}, Bit 17:** Calibration Due
- **[Active\_Warnings]{184-1-5}, Bit 18:** Totalizer Overflow
- **[Active\_Warnings]{184-1-5}, Bit 19:** Overhaul Due

### Note: Gas Calibration Object Instance

The value of this attribute is limited to the number of Process Gas Object instances configured in the device. The minimum value is 1, which is also the default value.

### Note: Totalizers

There are two totalizers: Flow Totalizer [126] and Custom Flow Totalizer [130]. The behavior of each totalizer is described in the following sections. The units of measure for both totalizers are set using Totalizer Units [125]. See Appendix C – Volume Flow Units table.

### Flow Totalizer

Flow Totalizer [126] is a count-up flow totalizer. The attribute can be set to any value. If this totalizer value exceeds Totalizer Overflow Threshold [230], status `Active_Warnings_Totalizer_Overflow {184-1-5}` will be set. Setting this totalizer value below the overflow threshold will clear the status.

## Section 6 Detailed Configuration

### Custom Flow Totalizer

Custom Flow Totalizer [130] is a count-up flow totalizer. This totalizer value is controlled by Custom Flow Totalizer Control [131]. Options for controlling the totalizer are Run (1), Stop (2), and Reset (3). Reading Custom Flow Totalizer Control [131] will return the current operational state of the timer: Run (1) or Stop (2). When the Reset (3) command is written to Custom Flow Totalizer Control [131], the totalizer will reset to zero, and then return to its operational state prior to writing the reset command.

### Note: Timers

There are two countdown timers, Overhaul Due [226] and Calibration Due [227], and one count-up timer Power On Hours [222].

### Countdown Timers

Overhaul Due [226] and Calibration Due [227] are countdown timers. These timers can be utilized to raise preventative maintenance and calibration events. Counting down commences when the device is flowing gas. When the counters reach zero, their respective status' [Active\_Alarms\_Overhaul\_Due] [184-1-5], and [Active\_Alarms\_Calibration\_Due] [184-1-5] will be set. Writing a non-zero value to these timers will clear their respective status'. These timers can be written to at any time.

### Count-Up Timers

Power On Hours [222] is a count-up timer that represents the total time, in hours, that the device has been powered on. This timer is not resettable.

### Services

Table 6-15: Flow Meter Instance Services

Service Code	Service Name	Service Description	Details
0x32	Get Zero History	Returns an entry in the Zero History Table [149]	(See 'Service Details')

## Section 6 Detailed Configuration

## Service Detail

Table 6-16: Get Zero History Service Arguments

Parameter Name	Data Type	Required	Parameter Value	Semantics
Array Index	UDINT	Y	1-128	This parameter is the index into the Zero History Table. A value of 1 is the most recent entry in the table, a value of 128 is the oldest entry.

Table 6-17: Get Zero History Service Response

Parameter Name	Data Type	Required	Parameter Value	Semantics
Calibration Instance	UDINT	Y	1-6	The Calibration Instance at the time of the zero operation
Zero Drift	REAL	Y	-	The Zero Drift prior to commencing the zero operation
Temperature	REAL	Y	-	The Temperature prior to commencing the zero operation
Power On Hours	REAL	Y	-	Total power on hours at the time of the zero operation

## Valve Driver Object [0x96]

Device Types: MFC

The Valve Driver is responsible for management of the actuator device controlling the process.

## Attributes

Table 6-18: Valve Driver Object Instance Attributes

ID	Name	Data Type	Access Rule	NV	Description	Notes
5	Override	DINT	Set	V	Specifies a direct override of the physical actuator	(See 'Note: Override' below)
6	Valve Position	REAL	Get	V	The value of the analog output signal used to drive the physical actuator	(See 'Note: Valve' below) Units in percent
18	Warning Trip Point High	REAL	Set	NV	Determines the value [6] above which a warning condition will occur	(See 'Note: Status' below) Units in percent
19	Warning Trip Point Low	REAL	Set	NV	Determines the Value [6] below which a warning condition will occur	(See 'Note: Status' below) Units in percent
20	Warning Hysteresis	REAL	Set	NV	Determines the Value [6] that must recover from a warning condition to clear the warning status	(See 'Note: Status' below)

## Section 6 Detailed Configuration

ID	Name	Data Type	Access Rule	NV	Description	Notes
21	Safe State	DINT	Set	NV	Specifies the behavior for the physical actuator in an Operational State other than Executing State	(See 'Note: Safe State' below)
22	Safe Value	REAL	Set	NV	The analog output signal value that is indicated by Value [6] if the Safe State [21] is configured to 'Use Safe Value'	Default = 0%
143	Control Warning Threshold	REAL	Set	NV	The threshold above which the computed standard deviation of Valve Position [6] exceeds will raise the Valve Control Warning status. A value of 0.0 disables this diagnostic.	(See 'Note: Valve Control Warning' below) Units in percent
144	Control Warning Settling Time	DINT	Set	NV	The time that standard deviation of 'Valve_Position' must exceed the Trip Point threshold before the Status Condition is raised. This value also sets the time that standard deviation of 'Valve_Position' has recovered from the Trip Point threshold before the associated status condition is cleared	(See 'Note: Valve Control Warning' below) Units in milliseconds

## Section 6 Detailed Configuration

### Note: Override

The following table outlines the valid actuator override types

Table 6-19: Override

Value	State	Description
0	Normal	Actuator is under normal operational control
1	Closed	Actuator is driven fully closed
2	Open	Actuator is driven fully open
3	Hold	Actuator is held to last updated analog output signal prior to assertion of override
4	Safe State	Actuator is driven to the condition specified by the Safe State [21] attribute

### Note: Valve

To interpret the value of this attribute, it is important to understand the following terms:

#### Operational Range:

This is the range that is reported by Value [6]. The operational range of the actuator is full range that the actuator can be driven to move. This corresponds to Value [6] values of 0 to 100%.

#### Nominal Control Range:

The nominal control range is a set of values that the actuator is driven to that maps directly between no flow and full-scale flow. This set of values is a subrange within the large operational range of the actuator. Example, the nominal control range for a 0 to 100 SCCM device flowing nitrogen could be as follows:

at 0 SCCM Actuator = 20%  
at 100 SCCM, Actuator = 30%

Under normal operational control (no override), the actuator generally operates in the nominal control range. The upper end of the control range is not an absolute limit under normal control. The controller will drive the actuator to whatever value is necessary to control flow. For example, if a restriction occurred upstream of the device resulting in reduced supply to the device, the controller will drive the actuator beyond the nominal control range to maintain control.

### Status

Status bits associated with this object are listed below. For details, see Section 7.

- **[Active\_Warnings]{184-1-5}, Bit 8:** Valve High Warning
- **[Active\_Warnings]{184-1-5}, Bit 9:** Valve Low Warning
- **[Active\_Warnings]{184-1-5}, Bit 10:** Valve Control Warning

## Section 6 Detailed Configuration

### Valve Control Warning

Valve control warning is based upon a statistical computation by computing a rolling standard deviation on the valve position. This diagnostic is disabled if the threshold value is set to 0.

### Safe State

The following table outlines valid values for this attribute. This table applies for normally closed and normally open valves.

Table 6-20: Safe State

Value	State	Description
0	Closed	The actuator will be driven closed (0%)
1	Open	The actuator will be driven open (100%)
2	Hold Last Value	The actuator will be driven to the last updated value of the analog output just prior to the entering of the safe state
3	Use Safe Value	The actuator will be driven to the value configured in Safe Value [22]

### Services

No Object Specific Services

### Flow Controller Object [0x9E]

Device Types: MFC

The Flow Controller object is responsible for closing the loop between the measured process variable (via the Flow Meter Object) and the control variable (via the Valve Drive Object).

### Attributes

Table 6-21: Flow Controller Object Instance Attributes

Attrib ID	Name	Data Type	Access Rule	NV	Description	Notes
4	Data Units	ENGUNITS	Set	NV	Defines the Engineering Units context of Setpoint [6] and other attributes in this object	(See 'Note: Data Units' below)
5	Control Override	DINT	Set	V	Overrides the automatic control of the flow controller	(See 'Note: Control Override')
6	Setpoint	REAL	Set	V	The sensor value that the device will maintain a steady state condition	Units set by [4]
15	Warning Settling Time	DINT	Set	V	Time allowed for the control-loop to settle to within the error band	(See 'Note: Status' below) Time in milliseconds

## Section 6 Detailed Configuration

Attrib ID	Name	Data Type	Access Rule	NV	Description	Notes
16	Warning Error Band	DINT	Set	NV	The maximum deviation band by which Setpoint must equal the Process Variable before a status is indicated	(See 'Note: Status' below) Units set by [4]
19	Constant Time Ramp Rate	UDINT	Set	NV	The amount of time the controller will take to “ramp” flow from its current value to its final value as commanded in Setpoint [6]	Default = 0 [disabled] Time in milliseconds
159	Fixed Control Value	REAL	Set	V	Sets the value actuator position when Control Override [5] is set to 'Fixed'	Units are %
194	Setpoint Limit	REAL	Set	NV	The maximum value for setpoint. If setpoint exceeds this value, the behavior of the controller is defined by Setpoint Limit Action [201]	Units set by [4]
201	Setpoint Limit Action	DINT	Set	NV	Sets the behavior of the controller when Setpoint [6] > Setpoint Limit [194]	(See 'Note: Setpoint Limit Action')
202	Live Setpoint	REAL	Get	V	The actual setpoint to which the process variable Flow will be controlled	(See section 7.2.10 for more information on Setpoint Limiting)

**Note: Data Units**

The value of this attribute is limited to the values specified in the Volumetric Flow Units Table and Mass Flow Units table in Appendix C - Data Units.

**Note: Status**

Status bits associated with this object are listed below. For details, see Section 7.

- **[Active\_Warnings]{184-1-5}, Bit 11:** Setpoint Deviation
- **[Active\_Warnings]{184-1-5}, Bit 13:** Setpoint Overrange
- **[Active\_Warnings]{184-1-5}, Bit 14:** Setpoint Limited

**Note: Setpoint Limited Action**

See section 7.2.10 for more information on Setpoint Limiting

Table 6-22: Setpoint Limiting Actions

Value	Description
0	Setpoint Limiting disabled
1	Raise 'Setpoint Over range' warning status, but do not actively limit the setpoint
2	Raise 'Setpoint Limited' status and actively limit the setpoint to Setpoint Limit [194]

## Section 6 Detailed Configuration

### Note: Control Override

Table 6-23: Setpoint Limiting Actions

Value	Description
0	Automatic Control
1	Control Override - Actuator Off
2	Control Override - Actuator Open 100%
129	Control Override - Set Actuator Position to the value in attribute 'Fixed Control Value' [159]

### Services

No Object Specific Services

### Process Gas Object [0x66]

Device Types: MFC and MFM

The Process Gas object defines characteristics associated with linearization/compensation of the gas flow sensor.

### Attributes

Table 6-24: Process Gas Instance 0 Attributes

Attrib ID	Name	Data Type	Access Rule	NV	Description	Notes
1	Revision	UINT	Get	NV	Revision of the Process Gas object class definition upon which the implementation is based.	If updates require an increase in this value, then the value of this attribute increases by 1. Range 1– 65535
2	Max Instance	UINT	Get	NV	The maximum instance ID of this object supported by the device	
3	Number of Instances	UINT	Get	NV	The number of instances of this object supported by the device	



## Section 6 Detailed Configuration

Table 6-25: Process Gas Instance 1..n Attributes

Attrib ID	Name	Data Type	Access Rule	NV	Description	Notes
37	Reference Temperature	REAL	Get	NV	The gas temperature, in Celsius, under which the calibration was performed	
38	Reference Pressure	REAL	Get	NV	The gas pressure, in Pa, under which this calibration was performed	
40	Gas Standard Number	DINT	Get	NV	The gas type number assigned to this gas	(See 'Note: Gas Standard Number' below) Default = 0, no gas type specified
42	Calibration Data Units	DINT	Get	NV	The engineering units of measure assigned to this gas	(See Appendix C for units codes)
45	Configured Range	REAL	Get	NV	The maximum calibrated flow value	
47	Total Flow Hours	REAL	Set	NV	The total number of hours flow through the device with this instance of the process gas page selected	
200	FAT Date	DATE	Set	NV	The factory acceptance date for this gas calibration	Number of days since 1972 0 = 01/01/1972

**Note: Gas Standard Number**

The Gas Standard Number as defined by SEMI publication SEMI E52-0298, "Practice for Referencing Gases Used in Digital Mass Flow Controllers."

**Services**

No Object Specific Services

**Temperature Meter Object [0xA4]**

Device Type(s): MFC and MFM

The Temperature Meter object measures the temperature of the process gas.

## Section 6 Detailed Configuration

### Attributes

Table 6-26: Temperature Meter Object Instance 1 Attributes

Attrib ID	Name	Data Type	Access Rule	NV	Description	Notes
4	Temperature Units	DINT	Set	NV	Sets the engineering units of measure of Temperature [6] and related attributes in this class	(See Appendix C for unit codes)
6	Temperature	REAL	Get	V	Temperature Sensor value	Units set by [4]
21	High Temperature Warning Trip Point	REAL	Set	NV	Sets the threshold above which an High Temperature status will occur	(See 'Note: Status' below) Units set by [4]
22	Low Temperature Warning Trip Point	REAL	Set	NV	Sets the threshold below which an High Temperature status will occur	(See 'Note: Status' below) Units set by [4]
24	Warning Trip Point Settling Time	REAL	Set	NV	Sets the time that Temperature [6] must exceed the Trip Point thresholds before the Status Condition is raised. This value also sets the time that 'Temperature' has recovered from the Trip Point threshold before the associated status condition is cleared	(See 'Note: Status' below) Time in milliseconds

### Status

Status bits associated with this object are listed below. For details, see section 7.

- **[Active\_Alarms]{184-1-4}, Bit 24:** Temperature Sensor Fail
- **[Active\_Warnings]{184-1-5}, Bit 24:** High Temperature
- **[Active\_Warnings]{184-1-5}, Bit 25:** Low Temperature Services

### Services

No Object Specific Services

### Status Object [0xB8]

The Status Object contains all the status bits that can be indicated by the device. Details of how each status indication functions and their associated attributes for configure the status function can be reference in Section 7

## Section 6 Detailed Configuration

**Attributes**

Table 6-27: Status Object Instance 1..n Attributes

Attrib ID	Name	Data Type	Access Rule	NV	Description	Notes
3	Active Errors	DWORD	Get	NV	Active Error Status Bits	(See 'Note: Active Errors')
4	Active Alarms	DWORD	Get	NV	Active Alarms Status Bits	(See 'Note: Active Alarms')
5	Active Warnings	DWORD	Get	NV	Active Warnings Status Bits	(See 'Note: Active Warnings')
6	Device Status	DWORD	Get	NV	Device Status Bits	(See 'Note: Device Status')
8	Alarms Mask	DWORD	Set	NV	Active Alarms Mask Bits	(See 'Note: Mask Bits')
9	Warnings Mask	DWORD	Set	NV	Active Warnings Mask Bits	(See 'Note: Mask Bits')

**Note: Active Errors**

Table 6-28: Active Error Bit Definitions

Bit(s)	Description
0-1	Reserved
2	Back Streaming Error
3-17	Reserved
18	Internal Communications Error
19-22	Reserved
23	NV Memory Fail
24-31	Reserved

**Note: Active Alarms**

Table 6-29: Active Alarms Bit Definitions

Bit(s)	Description
0	Low Flow Alarm
1	High Flow Alarm
2	No Flow Alarm
3	Choked Flow Alarm
4-14	Reserved
15	Invalid Process Gas Page Selected
16-22	Reserved
23	Using Backup NV Memory
24	Temperature Sensor Fail
25-31	Reserved

## Section 6 Detailed Configuration

**Note: Active Warnings***Table 6-30: Active Warnings Bit Definitions*

<b>Bit(s)</b>	<b>Description</b>
0	Low Flow Warning
1	High Flow Warning
2	Reserved
3	Choked Flow Warning
4	Excessive Zero Drift Warning
5	Bad Zero Warning
6-7	Reserved
8	Valve High Warning
9	Valve Low Warning
10	Valve Control Warning
11	Setpoint Deviation
12	Reserved
13	Setpoint Overrange
14	Setpoint Limited
15-16	Reserved
17	Calibration Due
18	Totalizer Overflow
19	Overhaul Due
20-23	Reserved
24	High Temperature
25	Low Temperature
26	Supply Volts High
27	Supply Volts Low
28-31	Reserved

## Section 6 Detailed Configuration

**Note: Device Status***Table 6-31: Device Status Bit Definitions*

Bit(s)	Description
0	Device is Executing
1	Flow Reading Valid
2	Temperature Reading Valid
3	Device is Zeroing
4	Zero Recommended
5	Zero Operation Inhibit
6-7	Reserved
8	Device Error
9	Device Alarm
10	Device Warning
11-31	Reserved

**Note: Mask Bits**

Active Alarms [4] and Active Warnings [5] can be masked by setting the corresponding bits in the mask attributes Alarms Mask [8] and Warnings [9]

**Services**

No Object Specific Services

## Section 7 Status

### Section 7: Status

#### Device Status {184-1-6}

There are four levels of status: Errors, Alarms, Warnings, and Device Status in decreasing order of severity. The corresponding tag names for the status attributes are:

- **[Active\_Errors] {184-1-3}**
- **[Active\_Alarms] {184-1-4},**
- **[Active\_Warnings] {184-1-5},**
- **[Device\_Status] {184-1-6}**

Each status word is an enumerated bitfield of type DWORD. These status bits are in the Status Class (Class ID 184) and are mapped to Produce Assemblies 201, 203.

**[Active\_Alarms] {184-1-4}** and **[Active\_Warnings] {184-1-5}** can be masked by setting the corresponding mask attributes **[Alarms\_Mask] {184-1-8}** and **[Warnings\_Mask] {184-1-9}**. A value of 0 for any mask bit blocks the correspond alarm or warning bit from being indicated. A value of 1 for any mask bit will allow the alarm or warning bit to be indicated.

**[Active\_Errors] {184-1-3}** and **[Device\_Status] {184-1-6}** cannot be masked. If any bit in **[Active\_Errors] {184-1-3}** is set, it will force the flow controller into the Safe State. The device will require a reset to return to normal operation. A reset of the device can be achieved through a power cycle or by sending the Reset service (Service ID 5) to the Identity Class (Class ID 0x01).

#### Bit 0: Device is Executing [Device\_Status\_Dev\_Exec]

This status indicates the current execution state of the device

Bit Value	Description
1	The device is Executing and controlling to setpoint
0	The device is in the Safe State

The state of this status bit is dependent on **[Active\_Errors]{184-1-3}** (see section 'Safe Mode') and the existence of a Class 1 connection.

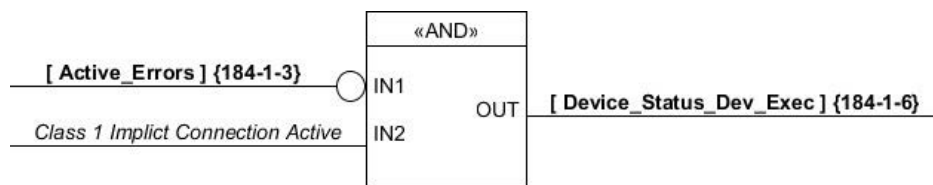

## Section 7 Status

**Bit 1: Flow Reading Valid [Device\_Status\_Flow\_Valid]**

This status indicates the quality of the flow sensor reading.

Bit Value	Description
1	The Flow Sensor operating nominally, and flow sensor readings are within normal range
0	Flow sensor reading is out of range and/or not operating nominally

NOTE: *Sensor.Underrange* and *Sensor.Overrange* are internal variables

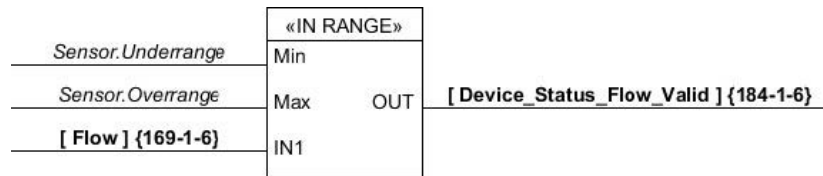
**Bit 2: Temperature Reading Valid [Device\_Status\_Temp\_Valid]**

This status indicates the quality of the temperature sensor reading.

Bit Value	Description
1	The temperature sensor operating nominally, and temperature sensor readings are within normal range
0	Temperature sensor reading is out of range and/or not operating nominally

NOTE: *Sensor.Underrange* and *Sensor.Overrange* are internal variables

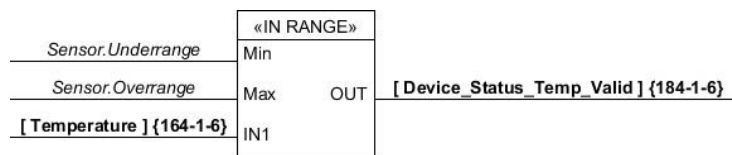
**Bit 3: Device Is Zeroing [Device\_Status\_Dev\_Zeroing]**

This status indicated the current state a sensor zero operation.

Bit Value	Description
1	The device is currently executing a Sensor Zero operation
0	Sensor Zero operation is complete

## Section 7 Status

**Bit 4: Zero Recommended [Device\_Status\_Zero\_Recommend]**

This status indicates that the device should be zeroed (Sensor Zero operation is recommended). This status will be set when either of the following conditions is met:

**Condition 1: Zero Warn Time Expired**

Power on time since the last Successful Zero Operation > [Zero\_Recommend\_Time {169-1-140}].

A Successful Zero Operation is defined as a completed Zero Operation that does not result in setting [Device\_Warn\_Bad\_Zero] {184-1-5} or [Device\_Warn\_Zero\_Drift] {184-1-5} warning statuses.

This diagnostic is disabled when [Zero\_Recommend\_Time] {169-1-140} = 0.

**Condition 2: Zero Out of Tolerance**

If [Ctrl\_Setpoint {158-1-6}] = 0 for > [Zero\_Tolerance\_Settle\_Time] {169-1-141}

AND

Abs ([Flow] {169-1-6}) > 0.5 \* [Zero\_Tolerance\_Band] {169-1-142}.

This diagnostic is disabled when [Zero\_Tolerance\_Band] {169-1-142} = 0.

Bit Value	Description
1	When one of the two above conditions have been met
0	A successful Zero Operation has been completed



## Section 7 Status

### Bit 5: Zero Operation Inhibit [Device\_Status\_Zero\_Op\_Inhibit]

This status indicates that the device cannot perform a zero operation. A sensor zero operation *will be inhibited* when **any** of the following conditions are present:

- **[Ctrl\_Setpoint] {158-1-6}** is not zero
- **[Valve\_Override] {150-1-5}** is not set to 'Normal'
- The device is in the Safe State AND **[Valve\_Safe\_State] {150-1-21}** is not set to 'Closed'
- Any Alarm is Active **[Active\_Alarms] {184-1-4}**
- Any Error is Active **[Active\_Errors] {184-1-3}**

Bit Value	Description
1	Device Zero operations are inhibited
0	Device Zero operations can be performed

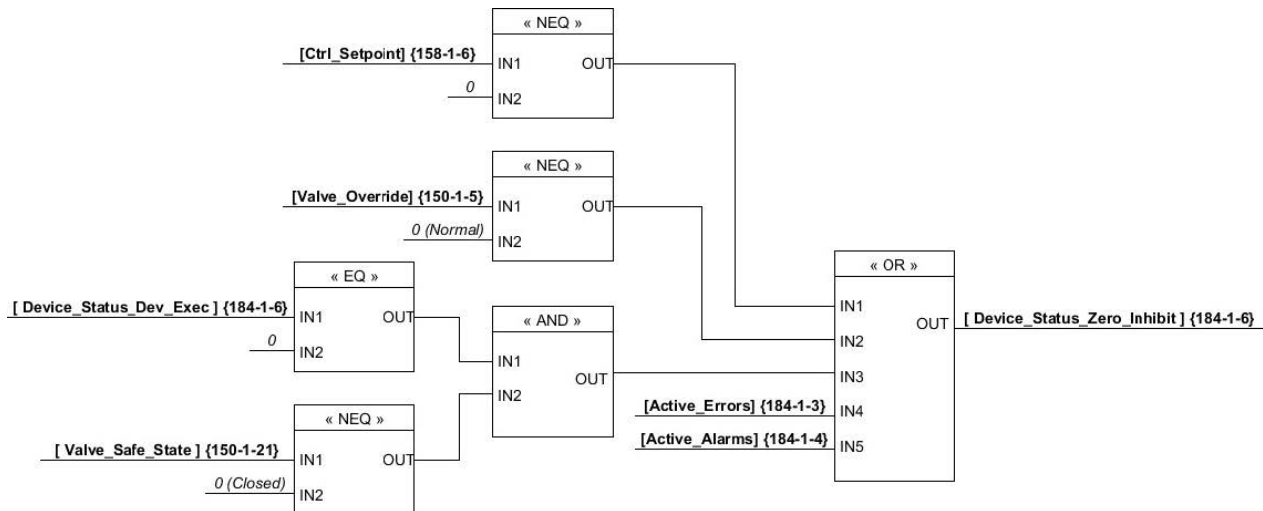

### Bit 6: Valve Override [Device\_Status\_Valve\_Override]

This status indicates the **[Valve\_Override] {150-1-5}** is engaged

Bit Value	Description
1	Valve Override is Active (i.e. Off, Purge)
0	Valve Override is Normal

## Section 7 Status

**Bit 7: Control Override [Device\_Status\_Ctrl\_Override]**

This status indicates if any [Ctrl\_Override] {158-1-5} is engaged

Bit Value	Description
1	Control Override is Active (i.e. Off, Purge, Fixed)
0	Control Override is Normal

**Bit 8: Device Error [Device\_Status\_Dev\_Error]**

This status indicates if any [Active\_Error] {184-1-3} are present

Bit Value	Description
1	One or more Errors are present
0	No Errors are present

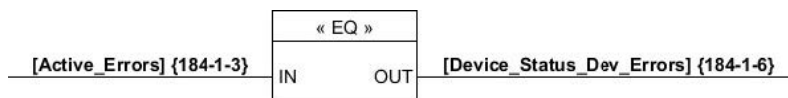
**Bit 9: Device Alarm [Device\_Status\_Dev\_Alarm]**

This status indicates if any [Active\_Alarm] {184-1-4} are present

Bit Value	Description
1	One or more Errors are present
0	No Errors are present

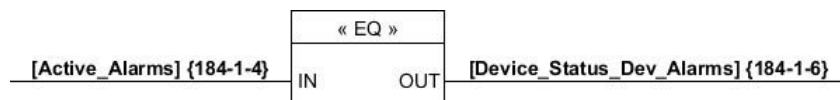
**Bit 10: Device Warning [Device\_Status\_Dev\_Warning]**

This status indicates if any [Active\_Warnings] {184-1-5} are present

Bit Value	Description
1	One or more Warnings are present
0	No Warnings are present

## Section 7 Status

**Bit 11: Zero Button Disabled [Device\_Status\_Zero\_Btn\_Disabled]**

This status indicates if any [Zero\_Btn\_Disable] {100-1-147} is set

Bit Value	Description
1	The zero button is disabled
0	The zero button is enabled

**Bit 12: Control Ramping [Device\_Status\_Ctrl\_Ramping]**

This status indicates that the controller is ramping to the new commanded setpoint. This status becomes enabled when [Ramp\_Time] {158-1-19} is set to a value other than 0

Bit Value	Description
1	The controller is ramping to the new commanded setpoint
0	The controller has reached the new commanded setpoint

## Section 7 Status

**Warnings {184-1-5}****Bit 0: Low Flow Warning [Active\_Warnings\_Low\_Flow]**

The status indicates a low flow warning condition exists.

This status is *disabled* when [Device\_Status\_Flow\_Valid] {184-1-6} = 0

See Diagram in section Typical Status High/Low Processing for typical behavior of this status.

Bit Value	Description
1	$[\text{Flow}] \{169-1-6\} < [\text{Flow\_Warn\_TP\_Low}] \{169-1-22\}$ <p style="text-align: center;">FOR</p> $\text{Time Period} > [\text{Flow\_Warn\_Settling\_Time}] \{169-1-24\}$
0	$[\text{Flow}] \{169-1-6\} > ( [\text{Flow\_Warn\_TP\_Low}] \{169-1-22\} + [\text{Flow\_Warn\_Hyst}] \{169-1-23\} )$ <p style="text-align: center;">FOR</p> $\text{Time Period} > [\text{Flow\_Warn\_Settling\_Time}] \{169-1-24\}$

**Bit 1: High Flow Warning [Active\_Warnings\_High\_Flow]**

This status indicates a high flow warning status condition.

This status is *disabled* when [Device\_Status\_Flow\_Valid] {184-1-6} = 0

See Diagram in section Typical Status High/Low Processing for typical behavior of this status.

Bit Value	Description
1	$[\text{Flow}] \{169-1-6\} > [\text{Flow\_Warn\_TP\_High}] \{169-1-21\}$ <p style="text-align: center;">FOR</p> $\text{Time Period} > [\text{Flow\_Warn\_Settling\_Time}] \{169-1-24\}$
0	$[\text{Flow}] \{169-1-6\} < ( [\text{Flow\_Warn\_TP\_High}] \{169-1-21\} - [\text{Flow\_Warn\_Hyst}] \{169-1-23\} )$ <p style="text-align: center;">FOR</p> $\text{Time Period} > [\text{Flow\_Warn\_Settling\_Time}] \{169-1-24\}$

## Section 7 Status

### Bit 3: Choked Flow Warning [Active\_Warnings\_Choked\_Flow]

This status indicates a choked flow alarm is imminent.

This status is **disabled** when **any** of the following conditions exist:

- [Device\_Status\_Flow\_Valid] {184-1-6} = 0
- [Active\_Alarms\_Choked\_Flow\_Alarm] {184-1-4} = 1
- [Ctrl\_Setpoint] {158-1-6} = 0.0
- [Valve\_Override] {150-1-5} = 1 (Off)

Bit Value	Description
1	$[\text{Flow}] \{169-1-6\} < ( [\text{Choked\_Flow\_Lim}] \{169-1-224\} * [\text{Ctrl\_Setpoint}] \{158-1-6\} )$ <p style="text-align: center;">AND</p> $[\text{Valve\_Position}] \{150-1-6\} > [70\% * \text{Max Valve Position}]$ <p style="text-align: center;">FOR</p> $\text{Time Period} > ( 30\% * [\text{Choked\_Flow\_Settling\_Time}] \{169-1-225\} )$
0	$[\text{Valve\_Position}] \{150-1-6\} < [70\% * \text{Max Valve Position}]$ <p style="text-align: center;">OR</p> $[\text{Flow}] \{169-1-6\} > ( [\text{Choked\_Flow\_Lim}] \{169-1-224\} * [\text{Ctrl\_Setpoint}] \{158-1-6\} )$

This warning status is a function of Setpoint and Settling Time whereby the trip point is a percentage of the current setpoint for 10% of the settling time.

**Example:** If [Choked\_Flow\_Limit] = 30%, [Choked\_Flow\_Settling\_Time] = 10 seconds, and the current setpoint [Ctrl\_Setpoint] = 80%, then the status will be raised when [Flow] < (30% \* 80%) or 24% for (30% \* 10 seconds) or 3 seconds.

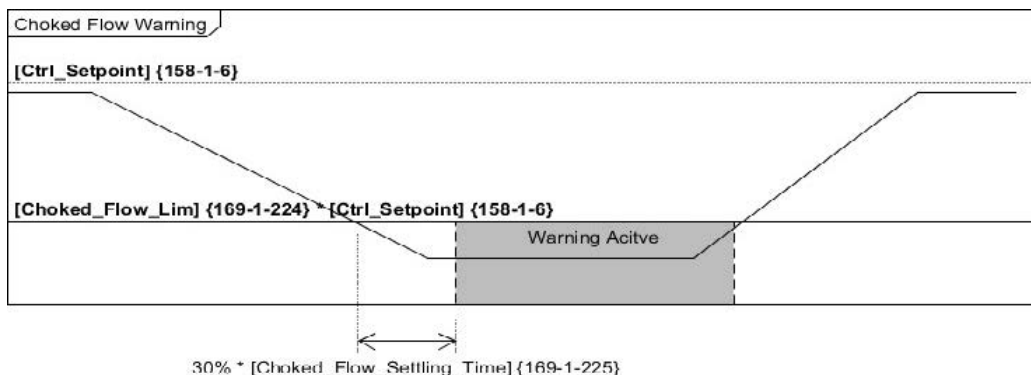

## Section 7 Status

**Bit 4: Excessive Zero Drift Warning [Active\_Warnings\_Zero\_Drift]**

This diagnostic indicates an excessive shift in zero since the last Zero Operation.

This diagnostic is run when [Ctrl\_Setpont] {158-1-6} = 0 for [Zero\_Warn\_Settle\_Time] {169-1-141}.

This diagnostic is *disabled* when [Zero\_Min\_Drift\_Time] {169-1-144} = 0

Bit Value	Description
1	<p>The previous Zero Operation was successful</p> <p>AND</p> <p>Time since Last Zero Operation &gt; [Zero_Min_Drift_Time] {169-1-144} AND</p> <p>The change in [Flow] {169-1-6} during the Zero Operation is:</p> <p>&gt; ( 0.2%FS/Year * [Excess_Drift_Mult] {169-1-145} + [Excess_Drift_Add] {169-1-146} )</p>
0	<p>The selected calibration gas page is changed</p> <p>OR</p> <p>[Zero_Min_Drift_Time] {169-1-144} = 0</p>

This diagnostic is detecting a drift in zero since the last time the device was zeroed. This is predicated upon two conditions:

- 1) the previous zero operation was successful and,
- 2) a sufficient amount of time has transpired since the last zero operation as defined by [Zero\_Min\_Drift\_Time] {169-1-144}.

## Section 7 Status

### Bit 5: Bad Zero Warning [Active\_Warnings\_Bad\_Zero]

This diagnostic indicates that the last Zero Operation was not successful.

This diagnostic is *disabled* when [Zero\_Success\_Band] {169-1-143} = 0

Bit Value	Description
1	<p><b>Zero Operation is Complete</b></p> <p>AND</p> <p><b>[Ctrl_Setpoint] {158-1-6} = 0</b></p> <p>AND</p> <p><b>[Flow] {169-1-6} &gt; [Zero_Success_Band] {169-1-143}</b></p>
0	<p>Zero Operation is Started</p> <p>OR</p> <p><b>[Zero_Success_Band] {169-1-143} = 0</b></p>

This diagnostic is performing a qualitative assessment on the result of the current zero operation based upon the flow signal after the zero. For this diagnostic to be as accurate as possible, a good process for zeroing the device should be in place and followed.

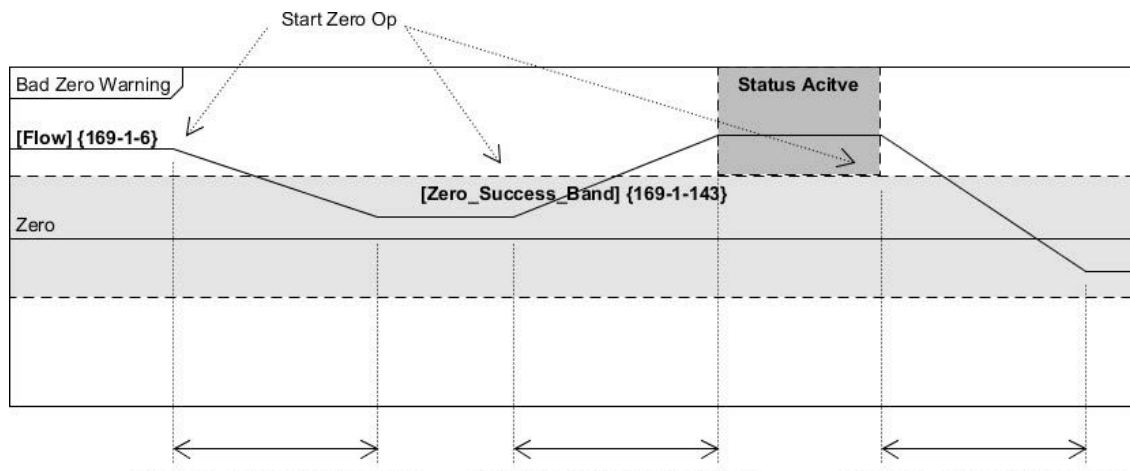

## Section 7 Status

**Bit 8: Valve High Warning [Active\_Warnings\_Valve\_High]**

The status indicates the valve position has exceeded a high position threshold.

See Diagram in section Typical Status High/Low Processing for typical behavior of this status.

Bit Value	Description
1	$[\text{Valve\_Position}] \{150-1-6\} > [\text{Valve\_Warn\_TP\_High}] \{150-1-18\}$
0	$[\text{Valve\_Position}] \{150-1-6\} < ([\text{Valve\_Warn\_TP\_High}] \{150-1-18\} + [\text{Valve\_Warn\_Hyst}] \{150-1-20\})$

**Bit 9: Valve Low Warning [Active\_Warnings\_Valve\_Low]**

The status indicates the valve position has exceeded a low position threshold.

See Diagram in section Typical Status High/Low Processing for typical behavior of this status.

Bit Value	Description
1	$[\text{Valve\_Position}] \{150-1-6\} < [\text{Valve\_Warn\_TP\_Low}] \{150-1-19\}$
0	$[\text{Valve\_Position}] \{150-1-6\} > ([\text{Valve\_Warn\_TP\_Low}] \{150-1-19\} + [\text{Valve\_Warn\_Hyst}] \{150-1-20\})$

**Bit 10: Valve Control Warning [Active\_Warnings\_Valve\_Ctrl]**

The Valve Control Warning diagnostic computes a rolling standard deviation of valve position and compares it to the threshold value set in attribute **[Valve\_Ctrl\_Warn\_Limit] {150-1-143}**. This diagnostic is disabled when **[Valve\_Ctrl\_Warn\_Limit] {150-1-143} = 0**.

See Diagram in section Typical Status High/Low Processing for typical behavior of this status.

Bit Value	Description
1	$\text{STDDEV}([\text{Valve\_Position}] \{150-1-6\}) > [\text{Valve\_Ctrl\_Warn\_Limit}] \{150-1-143\}$ FOR $\text{Time Period} > [\text{Valve\_Ctrl\_Warn\_Settling\_Time}] \{150-1-144\}$
0	$\text{STDDEV}([\text{Valve\_Position}] \{150-1-6\}) \leq [\text{Valve\_Ctrl\_Warn\_Limit}] \{150-1-143\}$ FOR $\text{Time Period} > [\text{Valve\_Ctrl\_Warn\_Settling\_Time}] \{150-1-144\}$



## Section 7 Status

### Bit 11: Setpoint Deviation [Active\_Warnings\_SP\_Deviation]

The status indicates the controller cannot control flow to within the error band within a defined settling time. This diagnostic is **disabled** when **any** of the following conditions exists:

- [Ctrl\_Setpoint] {158-1-6} = 0
- [Device\_Status\_Flow\_Valid] {184-1-5} = 0

Bit Value	Description
1	$[\text{Flow}] \{169-1-6\} > ( [\text{Ctrl\_Setpoint}] \{158-1-6\} + ( 0.5 * [\text{Ctrl\_Warn\_Error\_Band}] \{158-1-16\} ) )$ <p style="text-align: center;">OR</p> $[\text{Flow}] \{169-1-6\} < ( [\text{Ctrl\_Setpoint}] \{158-1-6\} - ( 0.5 * [\text{Ctrl\_Warn\_Error\_Band}] \{158-1-16\} ) )$ <p style="text-align: center;">FOR</p> $\text{Time Period} > [\text{Ctrl\_Warn\_Settling\_Time}] \{158-1-15\}$
0	$[\text{Flow} \{169-1-6\}] \leq ( [\text{Ctrl\_Setpoint}] \{158-1-6\} + ( 0.5 * [\text{Ctrl\_Warn\_Error\_Band}] \{158-1-16\} ) )$ <p style="text-align: center;">AND</p> $[\text{Flow}] \{169-1-6\} \geq ( [\text{Ctrl\_Setpoint}] \{158-1-6\} - ( 0.5 * [\text{Ctrl\_Warn\_Error\_Band}] \{158-1-16\} ) )$

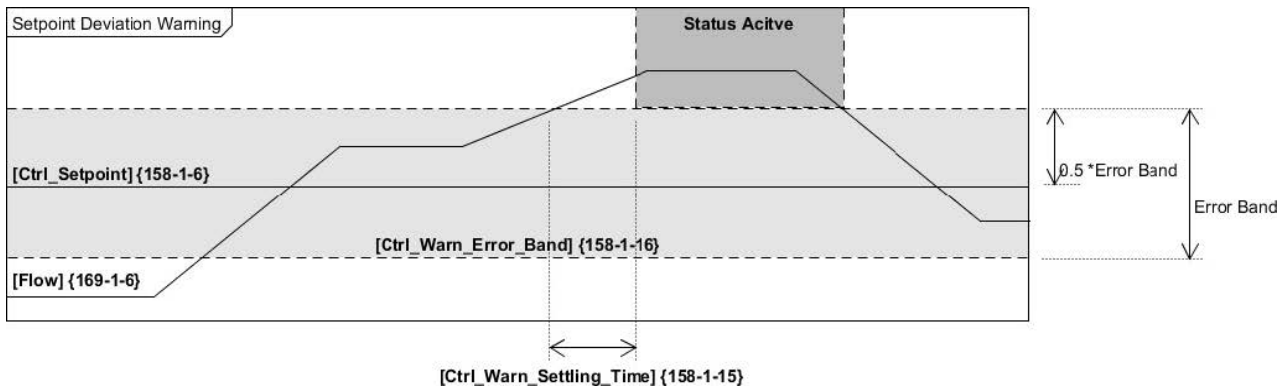

## Section 7 Status

### Bit 13: Setpoint Overrange [Active\_Warnings\_SP\_Ovrng]

The status indicates the current setpoint has exceeded an upper threshold.

This diagnostic is *disabled* when [Ctrl\_SP\_Lim\_Action] {158-1-201} = 0 (None)

Bit Value	Description
1	<p>[Ctrl_SP_Lim_Action] {158-1-201} = 1 (Raise Ovrng Warning)</p> <p>AND</p> <p>[Ctrl_Setpoint] {158-1-6} &gt; [Ctrl_SP_Lim] {158-1-194}</p> <p>FOR</p> <p>Time Period &gt; 1 second</p>
0	<p>[Ctrl_SP_Lim_Action] {158-1-201} = 2 (Limit Setpoint) OR 0 (None)</p> <p>OR</p> <p>[Ctrl_Setpoint] {158-1-6} &lt; [Ctrl_SP_Lim] {158-1-194}</p> <p>FOR</p> <p>Time Period &gt; 1 second</p>

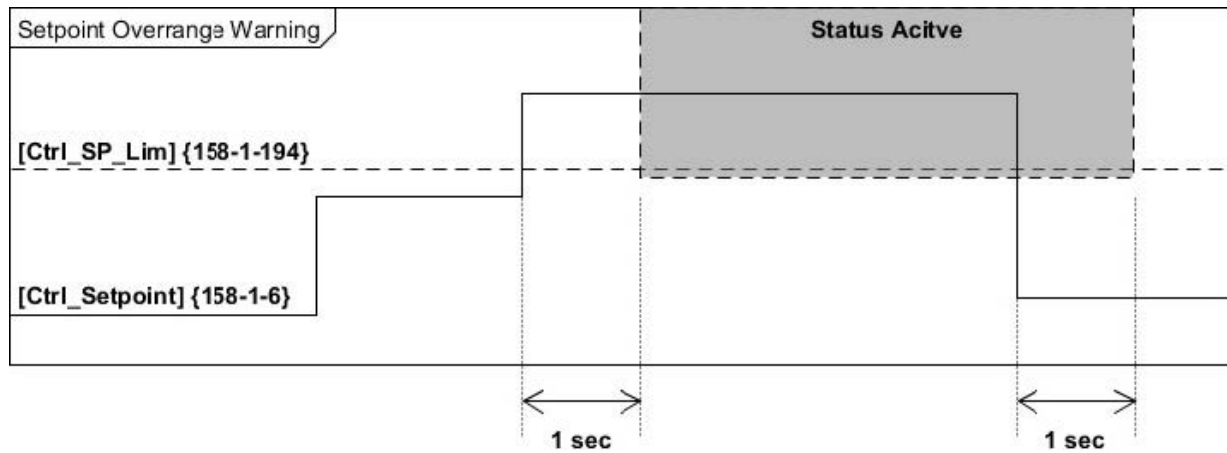

## Section 7 Status

### Bit 14: Setpoint Limited [Active\_Warnings\_SP\_Limited]

The status indicates the [Ctrl\_Setpoint] {158-1-6} has been limited by a [Ctrl\_SP\_Lim] {158-1-194}.

When [Ctrl\_Setpoint] {158-1-6} < [Ctrl\_SP\_Lim] {158-1-194} then [Ctrl\_Live\_Setpoint] {158-1-202} = [Ctrl\_Setpoint] {158-1-6}.

When [Ctrl\_Setpoint] {158-1-6} >= [Ctrl\_SP\_Lim] {158-1-194} then [Ctrl\_Live\_Setpoint] {158-1-202} = [Ctrl\_SP\_Lim] {158-1-194}.

This diagnostic is *disabled* when [Ctrl\_SP\_Lim\_Action] {158-1-201} = 0 (None)

Bit Value	Description
1	[Ctrl_SP_Lim_Action] {158-1-201} = 2 (Limit Setpoint) AND [Ctrl_Setpoint] {158-1-6} > [Ctrl_SP_Lim] {158-1-194} FOR Time Period > 1 second
0	[Ctrl_SP_Lim_Action] {158-1-201} = 2 (Limit Setpoint) OR 0 (None) OR [Ctrl_Setpoint] {158-1-6} < [Ctrl_SP_Lim] {158-1-194} FOR Time Period > 1 second

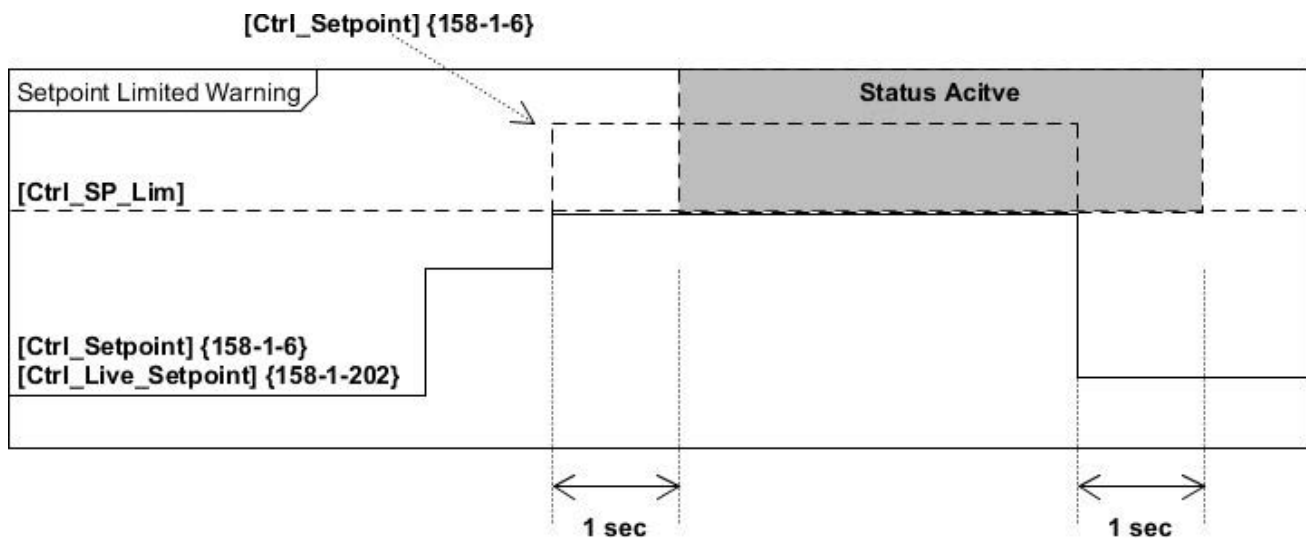

## Section 7 Status

**Bit 17: Calibration Due [Active\_Warnings\_Cal\_Due]**

This status indicates the devices needs to be calibrated.

See section Flow Meter Object, Section 6.x for details on Totalizers and Timers.

Bit Value	Description
1	[Cal_Due_Hours] {169-1-227} = 0
0	[Cal_Due_Hours] {169-1-227} > 0

**Bit 18: Totalizer Overflow [Active\_Warnings\_Total\_Ovflow]**

This status indicates that [Flow\_Totalizer] {169-1-126} has exceeded a defined overflow threshold.

See section Flow Meter Object, Section 6.x for details on Totalizers and Timers.

Bit Value	Description
1	[Flow_Totalizer] {169-1-126} > [Tot_Ovfl_Threshold] {169-1-230}
0	[Flow_Totalizer] {169-1-126} <= [Tot_Ovfl_Threshold] {169-1-230}

**Bit 19: Overhaul Due [Active\_Warnings\_Overhaul\_Due]**

This status indicates that device requires maintenance.

See section Flow Meter Object, Section 6.x for details on Totalizers and Timers.

Bit Value	Description
1	[Overhaul_Due_Hours] {169-1-226} = 0
0	[Overhaul_Due_Hours] {169-1-226} > 0

## Section 7 Status

**Bit 24: High Temperature Warning [Active\_Warnings\_High\_Temp]**

The status indicates a high internal device temperature warning condition.

See Diagram in section Typical Status High/Low Processing for typical behavior of this status.

Bit Value	Description
1	[Temperature] {164-1-6} > [High_Temp_Warn_TP] {164-1-21} FOR Time Period > [Temp_Warn_Setting_Time] {164-1-24}
0	[Temperature] {164-1-6} < [High_Temp_Warn_TP] {164-1-21} FOR Time Period > [Temp_Warn_Setting_Time] {164-1-24}

**Bit 25: Low Temperature Warning [Active\_Warnings\_Low\_Temp]**

This status indicates a low internal device temperature status condition.

See Diagram in section Typical Status High/Low Processing for typical behavior of this status.

Bit Value	Description
1	[Temperature] {164-1-6} < [Low_Temp_Warn_TP] {164-1-22} FOR Time Period > [Temp_Warn_Setting_Time] {164-1-24}
0	[Temperature] {164-1-6} > [Low_Temp_Warn_TP] {164-1-22} FOR Time Period > [Temp_Warn_Setting_Time]

**Bit 26: Supply Volts High [Active\_Warnings\_High\_Supply\_Volts]**

The status indicates the supply voltage is above the high warning trip point.

See Diagram in section Typical Status High/Low Processing for typical behavior of this status.

Bit Value	Description
1	[Supply_V] {100-1-191} < [Supply_V_Max_Limit] {100-1-192} FOR Time Period > [Supply_V_Settle_Time] {100-1-193}
0	[Supply_V] {100-1-191} > [Supply_V_Max_Limit] {100-1-192} FOR Time Period > [Supply_V_Settle_Time] {100-1-193}

## Section 7 Status

**Bit 27: Supply Volts Low [Active\_Warnings\_Low\_Supply\_Volts]**

The status indicates the supply voltage is below the low warning trip point.

See Diagram in section Typical Status High/Low Processing for typical behavior of this status.

Bit Value	Description
1	<p data-bbox="479 640 1224 674">[Supply_V] {100-1-190} &gt; [Supply_V_Min_Limit] {100-1-191}</p> <p data-bbox="824 688 878 716">FOR</p> <p data-bbox="537 737 1162 768">Time Period &gt; [Supply_V_Settle_Time] {100-1-193}</p>
0	<p data-bbox="479 777 1224 810">[Supply_V] {100-1-190} &lt; [Supply_V_Min_Limit] {100-1-191}</p> <p data-bbox="824 825 878 852">FOR</p> <p data-bbox="537 873 1162 905">Time Period &gt; [Supply_V_Settle_Time] {100-1-193}</p>

## Section 7 Status

**Alarms {184-1-4}****Bit 0: Low Flow Alarm [Active\_Alarms\_Low\_Flow]**

The status indicates a low flow alarm condition.

See Diagram in section Typical Status High/Low processing for typical behavior of this status.

This diagnostic is *disabled* when [Device\_Status\_Flow\_Valid] {184-1-6} = 0

Bit Value	Description
1	$[\text{Flow}] \{169-1-6\} < [\text{Flow\_Alarm\_TP\_Low}] \{169-1-18\}$ <p style="text-align: center;">FOR</p> $\text{Time Period} > [\text{Flow\_Alarm\_Settling\_Time}] \{169-1-23\}$
0	$[\text{Flow}] \{169-1-6\} > ( [\text{Flow\_Alarm\_TP\_Low}] \{169-1-18\} + [\text{Flow\_Alarm\_Hyst}] \{169-1-19\} )$ <p style="text-align: center;">FOR</p> $\text{Time Period} > [\text{Flow\_Alarm\_Settling\_Time}] \{169-1-23\}$

**Bit 1: High Flow Alarm [Active\_Alarms\_High\_Flow]**

This status indicates a high flow alarm condition.

See Diagram in section Typical Status High/Low Processing for typical behavior of this status.

This diagnostic is *disabled* when [Device\_Status\_Flow\_Valid] {184-1-6} = 0.

Bit Value	Description
1	$[\text{Flow}] \{169-1-6\} > [\text{Flow\_Alarm\_TP\_High}] \{169-1-17\}$ <p style="text-align: center;">FOR</p> $\text{Time Period} > [\text{Flow\_Alarm\_Settling\_Time}] \{169-1-23\}$
0	$[\text{Flow}] \{169-1-6\} < ( [\text{Flow\_Alarm\_TP\_High}] \{169-1-17\} - [\text{Flow\_Alarm\_Hyst}] \{169-1-19\} )$ <p style="text-align: center;">FOR</p> $\text{Time Period} > [\text{Flow\_Alarm\_Settling\_Time}] \{169-1-23\}$

## Section 7 Status

### Bit 2: No Flow Alarm [Active\_Alarms\_No\_Flow]

This status indicates a no flow conditions exists.

This diagnostic is *disabled* when *any* of the following conditions exist:

- [Device\_Status\_Flow\_Valid] {184-1-6} = 0
- [Ctrl\_Setpoint] {158-1-6} = 0
- [Valve\_Override] {150-1-5} = 1 (Off)

Bit Value	Description
1	$[\text{Flow}] \{169-1-6\} < ([\text{No\_Flow\_Lim}] \{169-1-222\} * [\text{Ctrl\_Setpoint}] \{158-1-6\})$ <p style="text-align: center;">AND</p> $[\text{Valve\_Position}] \{150-1-6\} > [70\% * \text{Max Valve Position}]$ <p style="text-align: center;">FOR</p> $\text{Time Period} > [\text{No\_Flow\_Settling\_Time}] \{169-1-223\}$
0	$[\text{Flow}] \{169-1-6\} > ([\text{No\_Flow\_Lim}] \{169-1-222\} * [\text{Ctrl\_Setpoint}] \{158-1-6\})$ <p style="text-align: center;">OR</p> $[\text{Valve\_Position}] \{150-1-6\} < [70\% * \text{Max Valve Position}]$ <p style="text-align: center;">FOR</p> $\text{Time Period} > [\text{No\_Flow\_Settling\_Time}] \{169-1-223\}$

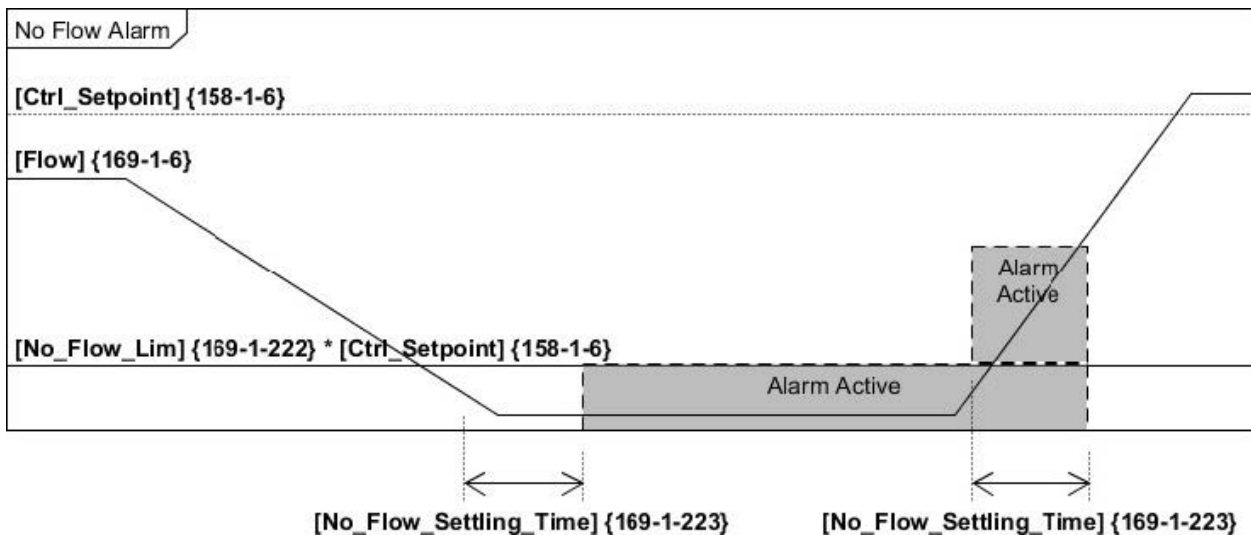



## Section 7 Status

### Bit 3: Choked Flow Alarm [Active\_Alarms\_Choked\_Flow]

This status indicates a choked flow condition exists.

This diagnostic is *disabled* when *any* of the following conditions exist:

- [Device\_Status\_Flow\_Valid] {184-1-6} = 0
- [Ctrl\_Setpoint] {158-1-6} = 0
- [Valve\_Override] {150-1-5} = 1 (Off)

Bit Value	Description
1	$[\text{Flow}] \{169-1-6\} < ( [\text{Choked\_Flow\_Lim}] \{169-1-224\} * [\text{Ctrl\_Setpoint}] \{158-1-6\} )$ <p style="text-align: center;">AND</p> $[\text{Valve\_Position}] \{150-1-6\} > [70\% * \text{Max Valve Position}]$ <p style="text-align: center;">FOR</p> <p style="text-align: center;">Time Period &gt; [Choked_Flow_Setting_Time] {169-1-225}</p>
0	$[\text{Flow}] \{169-1-6\} > ( [\text{Choked\_Flow\_Lim}] \{169-1-224\} * [\text{Ctrl\_Setpoint}] \{158-1-6\} )$ <p style="text-align: center;">OR</p> $[\text{Valve\_Position}] \{150-1-6\} < [70\% * \text{Max Valve Position}]$ <p style="text-align: center;">FOR</p> <p style="text-align: center;">Time Period &gt; [Choked_Flow_Setting_Time] {169-1-225}</p>

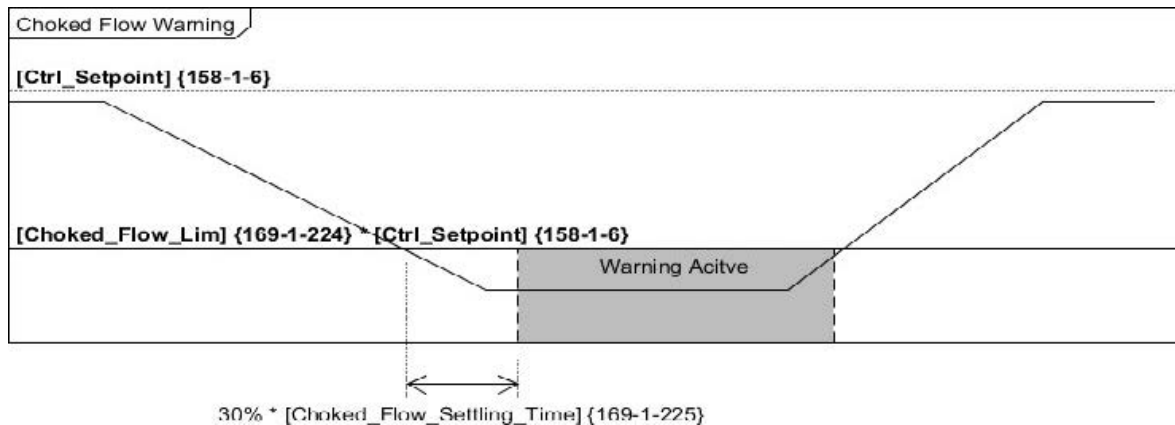

## Section 7 Status

**Bit 15: Invalid Process Gas Page Selected [Active\_Alarms\_Invalid\_Cal\_Page]**

This status indicates that an invalid process gas page ID is being selected through output assembly 101 or assembly 102. This status will be set but the process gas page will not be changed.

Bit Value	Description
1	This bit is set when an invalid process gas page ID is received by the device
0	The process gas page received by the device is valid

**Bit 23: Using Backup NV Memory [Active\_Alarms\_NV\_Mem]**

This status indicates that primary non-volatile memory has failed, and the device is using backup nonvolatile memory.

Bit Value	Description
1	This bit is set when NV Memory write failure has been detected
0	Indicates NV Memory write failure has not occurred

**Bit 24: Temperature Sensor Fail [Active\_Alarms\_Temp\_Sens\_Fail]**

This status indicates the operational status of the temperature sensor.

Bit Value	Description
1	Indicates the temperature sensor is non-functional
0	Indicates the temperature sensor is functional

## Section 7 Status

**Errors {184-1-3}****Bit 2: Back Streaming Error [Active\_Errors\_Bk\_Stream]**

This status indicates that back stream condition exists.

This diagnostic is *disabled* when *any* of the following conditions exist:

- [Valve\_Override] {150-1-5} = 2 (Purge)
- [Device\_Status\_Dev\_Zeroing] {184-1-6} = 1
- [Devcie\_Status\_Dev\_Alarms] {184-1-6} = 1
- [Device\_Status\_Dev\_Exec] {184-1-6} = 0

Bit Value	Description
1	[Flow] < [Bk_Stream_Flow_Lim] FOR Time Period > [Bk_Stream_Time_Lim]
0	This bit can only be cleared with a reset of the device

**Bit 18: Internal Communication Error [Active\_Errors\_Int\_Comms]**

This status indicates that a communications error between the Main Board and the EIP Adapter board has been detected.

Bit Value	Description
1	Error Detected
0	This bit can only be cleared with a reset of the device

**Bit 23: NV Memory Fail [Active\_Errors\_NV\_Mem\_Fail]**

This status indicates that both primary and backup non-volatile memories have had write failures detected.

Bit Value	Description
1	Non-volatile memory fail detected
0	This bit can only be cleared with a reset of the device

## Section 7 Status

### Typical Status High/Low Processing

The following diagrams represent typical Status Low and Status High processing of signals. Several status definitions reference these diagrams.

#### Status Low Processing

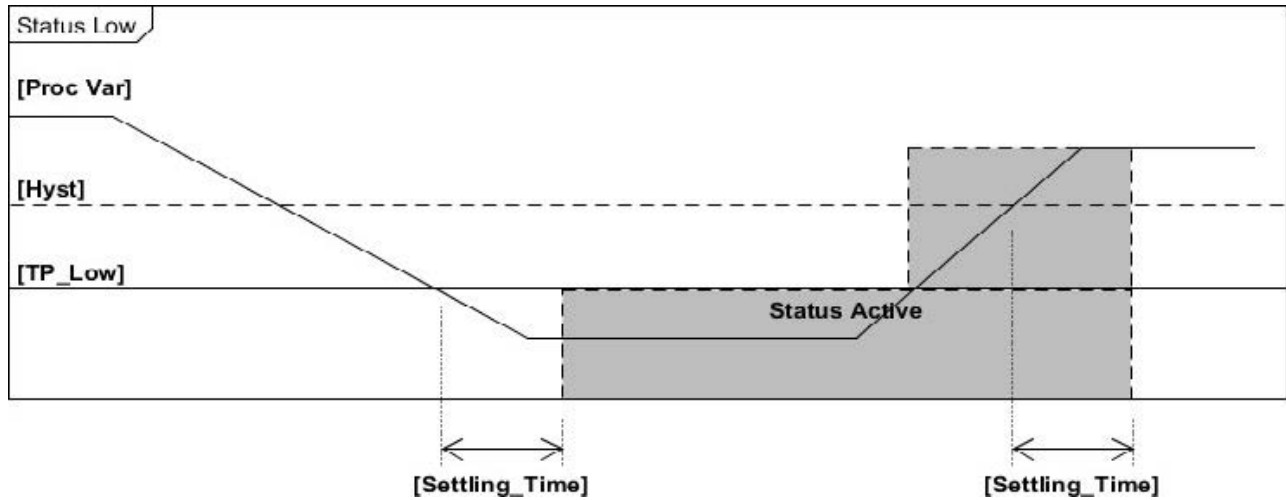

#### Status High Processing

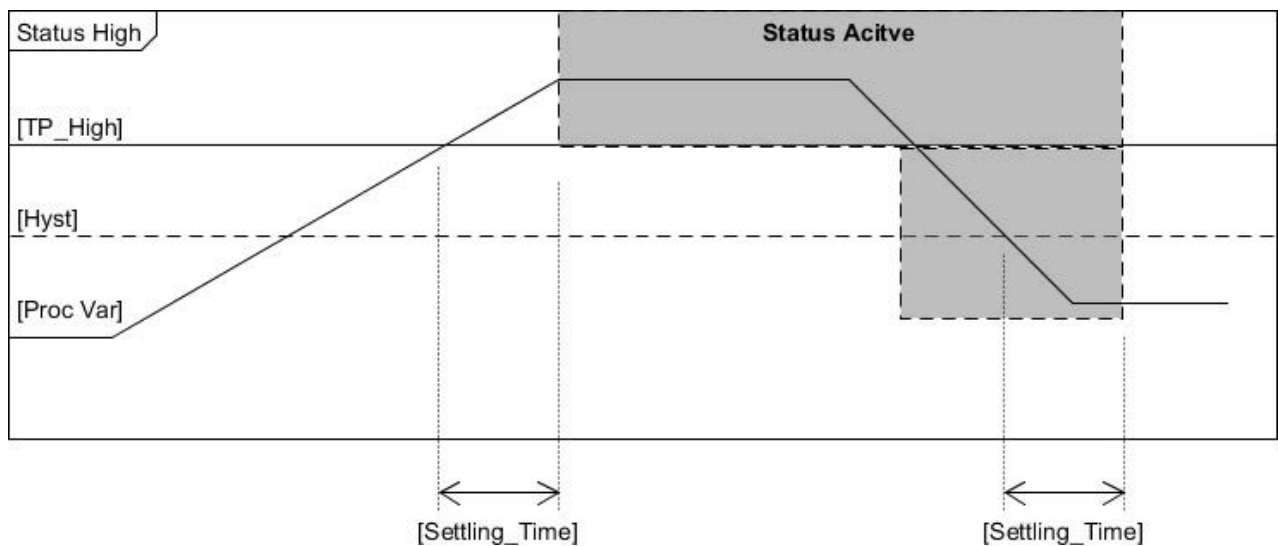

## Section 8 Troubleshooting

## Section 8: Troubleshooting

Problem	Possible Causes
Scanner is actively scanning the network, but the NET LED is flashing green and MOD LED is solid green	<p>The TCP/IP address for the device is not programmed into the scanner or does not match a device address already programmed in the scanner</p> <p>The TCP/IP address for the device is programmed into the scanner. Scanner cannot connect to the device because of one of the following:</p> <ol style="list-style-type: none"> <li>1) The Produce/Consume/Config assembly data sizes are mismatched. The sizes programmed into the master/scanner do not match the connection configuration. See section 'Class 1 Connections' or reference the EDS file for the correct assembly sizes</li> <li>2) The Input/Output/Config assembly IDs for the connection configuration are mismatched. See section 'Class 1 Connections' or reference the EDS file for the correct assembly ID's</li> <li>3) The scanner is programmed to send data to the configuration assembly when the connection is established, however one or more of the data fields in the configuration data have invalid values.</li> </ol>
Scanner is actively scanning the network and NET LED goes from solid green to flashing red and the MOD LED is solid green.	The exclusive owner connection to the device has timed out and has not been re-established.
When power is applied to the device the NET LED goes solid red and the MOD LED is solid green.	The IP address configured in the device conflicts with another device on the network.
When power is applied to the device the NET LED remains off and the MOD LED is solid green.	An TCP/IP Address has not been assigned to the device.
When power is applied to the device, the MOD LED switches from flashing Red/Green to solid Red.	Cycle power to the device. If problem persists, contact Brooks Instrument Technical Services.
The device never comes out of Self-Test (MOD LED continually flashes red/green).	Cycle power to the device. If problem persists, contact Brooks Instrument Technical Services.
A setpoint value is being sent to the device, but the MFC fails control flow (i.e. no actuator movement, low or no flow indication)	Check to make sure that the scanner is not setting the Run/Idle bit to Idle. This can occur if the scanner is put into a special program mode or the device in question has been placed into an "Idle" or "Inhibit" mode.

## Section 9 Appendix

### Section 9: Appendix

#### Appendix A - Ethernet/IP Connections

SLA EIP MFC support Class 1 Messaging connections and Class 3 Messaging connections. Class 1 connections are used to pass a grouping of data continuously between the Master scanner and the target device at fast update rates. The grouping of data is defined by Assembly objects (see section 'Data Assemblies'). The Assemblies are defined to be used with certain connection types. The following sections discuss the following connections types and how they might be utilized on an Ethernet/IP network.

##### Exclusive Owner Connection

The terms Originator(O) and Target(T) are sometimes used to refer to the two devices respectively. With the Exclusive Owner connection, ownership of the device is established, and data is generally (not always) exchanged in both directions. The Owner-to-Target (O or T) connection is usually point-to-point (unicast). The Target-to-Owner (T or O) connection can be either unicast or multicast. Unicast restricts the data exchange between the two devices only. A multicast connection allows other devices to subscribe to the data being exchanged in the T or O connection using Listen Only connections if the target device supports this type of connection for the data assembly.

##### Input Only Connection

The Input Only connection establishes and exchange of data, primarily from the Target to the Owner (T or O). The Originator of this connection can be any device on the network including the Owner device. The T or O data is 0 length (NULL) and is used as a 'heartbeat' to keep the connection active. The Target-to-Owner (T or O) connection can be either unicast or multicast. Unicast restricts the data exchange between the two devices only. A multicast connection allows other devices to subscribe to the data being exchanged in the T or O connection using Listen Only connections if the target device supports this type of connection for the data assembly.

##### Listen Only Connection

The Listen Only connection allows devices to subscribe to a multicast connection stream from a target device provided that the data assembly used for the connection supports Listen Only. The Originator of this connection can be any device on the network including the Owner device. The pre-requisite to creating this connection is that a multicast connection from the Target must exist (see Exclusive Owner or Input Only connections). The T or O data is 0 length (NULL) and is used as a 'heartbeat' to keep the connection active. The Target-to-Owner (T O) connection is added to the subscription stream in the Target device and the Owner will begin to receive data from the multicast stream.

## Section 9 Appendix

**Appendix B - Data Type Definitions**

The following table list ODVA data types used throughout this manual and in the ODVA specification. The column C/C++ Encoding is given as a comparative common example reference.

*Table 9-1 Data Types*

<b>Data Type</b>	<b>Size (bytes)</b>	<b>Description</b>	<b>Range</b>	<b>C/C++ Keyword</b>
BOOL	1	A true/false represented as 0 = false and 1 = true	0 and 1	bool
SINT	1	An 8-bit signed integer value	-128 to 127	char
USINT	1	An 8-bit unsigned integer value	0 to 255	unsigned char
INT	2	A 16-bit signed integer value	-32768 to 32767	short int
UINT	2	A 16-bit unsigned integer value	0 to 65535	unsigned short int
DINT	4	A 32-bit signed integer value	-2147483648 to 2147483647	int
UDINT	4	A 32-bit unsigned integer	0 to 4294967296	unsigned int
REAL	4	An IEEE single precision floating point number	3.4E38 to -3.4E38	float
DREAL	8	An IEEE double precision floating point number		Long
ENGUNIT	2	An enumerated value representing an engineering unit of measure	4096 - 65535	N/A
BYTE	1	An 8-bit Bitfield	N/A	N/A
SHORT STRING	Up to 128 bytes	A character array where the first byte is the number of characters in the array, and the subsequent bytes contain the ASCII characters. This is not a NULL terminated string.	N/A	N/A

## Section 9 Appendix

## Appendix C – Data Units

Table 9-2: Volumetric Flow Units Table

Description	Symbol	Units Code	
		Decimal	Hex
Percent	%	4103	0x1007
Barrels per Day	bbl/day	2072	0x0818
Barrels per Hour	bbl/hr	2071	0x0817
Barrels per Minute	bbl/min	2070	0x0816
Barrels per Second	bbl/sec	2069	0x0815
Cubic Centimeters per Day	cc/day	2051	0x0803
Cubic Centimeters per Hour	cc/hr	2050	0x0802
Cubic Centimeters per Minute	cc/min	2049	0x0801
Cubic Centimeters per Second	cc/sec	2048	0x0800
Cubic Foot per Day	cu ft/day	2059	0x080B
Cubic Foot per Hour	cu ft/hr	2058	0x080A
Cubic Foot per Minute	cu ft/min	5122	0x1402
Cubic Foot per Second	cu ft/sec	2057	0x0809
Gallons per Day	gal/day	2064	0x0810
Gallons per Hour	gal/hr	5130	0x140A
Gallons per Minute	gal/min	5129	0x1409
Gallons per Second	gal/sec	5128	0x1408
Grams per Day	g/day	2075	0x081B
Grams per Hour	g/hr	2074	0x081A
Grams per Minute	g/min	5135	0x140F
Grams per Second	g/sec	2073	0x0819
Imperial Gallons per Day	imp gal/day	2068	0x0814
Imperial Gallons per Hour	imp gal/hr	2067	0x0813
Imperial Gallons per Minute	imp gal/min	2066	0x0812
Imperial Gallons per Second	imp gal/sec	2065	0x0811
Cubic Inch per Day	cu in/day	2063	0x080F
Cubic Inch per Hour	cu in/hr	2062	0x080E
Cubic Inch per Minute	cu in/min	2061	0x080D
Cubic Inch per Second	cu in/sec	2060	0x080C
Kilograms per Day	kg/day	2077	0x081D
Kilograms per Hour	kg/hr	5136	0x1410
Kilograms per Minute	kg/min	2076	0x081C
Kilograms per Second	kg/sec	5124	0x1404
Pounds per Day	lbs/day	2078	0x081E
Pounds per Hour	lbs/hr	5133	0x140D
Pounds per Minute	lbs/min	5132	0x140C
Pounds per Second	lbs/sec	5131	0x140B



## Section 9 Appendix

Table 9-2: Volumetric Flow Units Table Continued

Description	Symbol	Units Code	
		Decimal	Hex
Liters per Day	L/day	2053	805
Liters per Hour	L/hr	5140	0x1414
Liters per Minute	L/min	5139	0x1413
Liters per Second	L/sec	5126	0x1406
Cubic Meters per Day	m3/day	2056	0x0808
Cubic Meters per Hour	m3/hr	2055	0x0807
Cubic Meters per Minute	m3/min	2054	0x0806
Cubic Meters per Second	m3/sec	5125	0x1405
Milliliters per Day	mL/day	2052	0x0804
Milliliters per Hour	mL/hr	5138	0x1412
Milliliters per Minute	mL/min	5137	0x1411
Milliliters per Second	mL/sec	5127	0x1407
Ounces per Day	oz/day	2082	0x0822
Ounces per Hour	oz/hr	2081	0x0821
Ounces per Minute	oz/min	2080	0x0820
Ounces per Second	oz/sec	2079	0x081F
Standard Cubic Centimeters per Second	sccm	5120	0x1400
Standard Liters per Minute	SLPM	5121	0x1401

Table 9-3: Actuator Units

Description	Symbol	Units Code	
		Decimal	Hex
Percent	%	4103	0x1007

Table 9-4: Temperature Units

Description	Symbol	Units Code	
		Decimal	Hex
deg C	°C	4608	0x1200
deg F	°F	4609	0x1201

Table 9-5: Volume Units Table Used by Totalizers

Description	Symbol	Units Code	
		Decimal	Hex
Liter	L	11778	0x2E02
Cubic Centimeter	cm3	11793	0x2E11

## Section 9 Appendix

## Appendix D - Service Summary Details

Table 9-6: Get Attribute Single Service Parameters

Parameter Name	Data Type	Required	Description	Default
Attribute ID	USINT	Y	The attribute ID of the attribute to be read	None

Table 9-7: Success Response Data

Return Value	Data Type	Description
Attribute Value	The Data Type of the Attribute being read	

Table 9-8: Set Attribute Single Service Parameters

Parameter Name	Data Type	Required	Description	Default
Attribute ID	USINT	Y	The attribute ID of the attribute to be read	None
Attribute Value	(Equivalent to the data type of the Attribute)	Y	The value to which the attribute will be set	None

Table 9-9: Success Response Data

Return Value	Data Type	Description
No Success Response Data		

## Section 10 Glossary

### Section 10: Glossary

This section is intended as a brief overview of Ethernet/IP™ terminology used throughout this manual.

#### **Assembly**

An Assembly is a Class that defines a collection of EPATH(s). This collection allows multiple attributes to be virtually accessed all at once. Each instance of an Assembly defines a unique set of EPATH(s).

#### **Attribute**

A Parameter or Data Item that may be read or written and is used for the purpose of configuration or is used to obtain information.

#### **Example:**

The attribute Data Units defines the engineering units flow will be reported in. The attribute Value indicates the current flow through the device. Attributes can be read/write or read only.

#### **Class**

A logical collection of related Attributes that define a particular function and/or behavior.

#### **Example:**

The class S-Analog Sensor contains information about configuring a sensor, the current status of the sensor, and/or the current value of what is being sensed.

#### **Connection**

A connection is a logical link between two devices by which messages are transferred. A device can have 1 or more simultaneous Connections.

#### **Device Profile**

A specification that defines a set of CIP objects that uniquely represents a particular device of that type or class. The device profile can further define attributes, services, assemblies, etc. that a device must support to be considered part of that type or class of device. These profiles are found in the ODVA specification, Vol. 1. The SLA Series MFC/MFM conforms to the Generic device profile.

#### **EDS**

The Electronic Data Sheet (EDS) is a specially formatted text description for a device that describes the connection characteristics and configurable parameters that are accessible via the Ethernet/IP™ network. EDS files can be read by configuration software used to configure Ethernet/IP™ networks.

#### **EPATH**

An EPATH is a unique identifier (sometimes referred to as a pointer) comprised of a Class ID, an Instance ID, and an Attribute ID. Some Classes have EPATH attributes that point to a particular data item. An example of this would be the Connection Class that contains two attributes, Produce Path and Consume Path. These attributes define where incoming data is sent to, and outgoing data comes from.

## Section 10 Glossary

### **Expected Packet Rate (EPR)**

The EPR is an attribute in the Connection Class that defines the maximum amount of time (in msec) messages should be received by the Connection (implementation of this value is dependent upon the Connection type, Class 1 or Class 3, but the behavior is the same in all Connection types). If the time between received messages for that connection exceeds the EPR, the Connection times out. This may result in the Connection being released by the device.

### **Class 3 Connection**

A Class 3 Connection dictates a request and response exchange between two devices. The device sending the request must get a response from the device receiving the request message. Embedded in the Message is information about the Class, Instance, Attribute, Service, and any service data needed to process the message. As a result, processing of Messages generally takes longer than Class 1 messaging. This is why Class 3 Connections are typically used for commissioning/configuration.

### **Class 1 Connection**

Class 1 Connections are used for the exchange of data only. How a device processes the data and/or responds with data via an Connection is defined within the Connection(s) configurations.

### **Instance**

An instance of a Class is a particular invocation of a Class (sometimes referred to as an Object). An Instance of a Class is unique in describing the behavior for a particular kind of object. Each instance of the class contains the same set of attributes defined by the class. The uniqueness of the instance is defined by the attribute values.

### **Safe State (Safe Mode)**

An operational mode or state that is considered “safe” whereby the normal controller process is shut down and mechanical and sensing mechanisms are placed in a safe condition.

### **Service**

A service is a pre-defined action that a Class provides. The most commonly used services are used to configure the device such as Get Attribute (0x0E) or Set Attribute (0x10). Other types of services may directly affect the behavior of a Class (or Object) such as Reset (0x5), Stop (0x6), or Start (0x7). There are many more services not listed here and each Class specifies which Services it supports.

## LIMITED WARRANTY

Visit [www.BrooksInstrument.com](http://www.BrooksInstrument.com) for the terms and conditions of our limited warranty.

## BROOKS SERVICE AND SUPPORT

Brooks is committed to assuring all our customers receive the ideal flow solution for their application, along with outstanding service and support to back it up. We operate first class repair facilities located around the world to provide rapid response and support. Each location utilizes primary standard calibration equipment to ensure accuracy and reliability for repairs and recalibration and is certified by our local Weights and Measures Authorities and traceable to the relevant International Standards.

*Visit [www.BrooksInstrument.com](http://www.BrooksInstrument.com) to locate the service location nearest to you.*

## START-UP SERVICE AND IN-SITU CALIBRATION

Brooks Instrument can provide start-up service prior to operation when required.

For some process applications, where ISO-9001 Quality Certification is important, it is mandatory to verify and/or (re)calibrate the products periodically. In many cases this service can be provided under in-situ conditions, and the results will be traceable to the relevant international quality standards.

## SEMINARS AND TRAINING

Brooks Instrument can provide seminars and dedicated training to engineers, end users and maintenance persons.

*Please contact your nearest sales representative for more details.*

Due to Brooks Instrument's commitment to continuous improvement of our products, all specifications are subject to change without notice.

## TRADEMARKS

Brooks is a trademark of Brooks Instrument, LLC  
All other trademarks are the property of their respective owners.



EtherNetIP-Manual-SLA-Series-EN/541B229AAG/2023-1

### Global Headquarters

**Brooks Instrument**  
407 West Vine Street  
Hatfield, PA  
19440-0903 USA

Toll-Free (USA): 888-554-FLOW  
T: 215-362-3500

[BrooksAM@BrooksInstrument.com](mailto:BrooksAM@BrooksInstrument.com)

A list of all Brooks Instrument locations and contact details can be found at [www.BrooksInstrument.com](http://www.BrooksInstrument.com)

© Copyright 2023 Brooks Instrument, LLC All rights reserved. Printed in U.S.A.

**BROOKS**<sup>®</sup>  
**INSTRUMENT**  
*Beyond Measure*